

STATE OF NORTH CAROLINA  
DEPARTMENT OF TRANSPORTATION  
RALEIGH, N.C.

C204116

CONTRACT AND  
CONTRACT BONDS

FOR CONTRACT NO. C204116

WBS 53012.3.1 NHPIM-0085(037)

T.I.P NO. I-5770, I-5796

COUNTY OF MECKLENBURG  
THIS IS THE ROADWAY CONTRACT  
ROUTE NUMBER I85 LENGTH 7.809 MILES  
LOCATION I-85 FROM CONC PVMT JOINT 0.3 MILES SOUTH OF NC-16 TO  
CONC PVMT JOINT SOUTH OF SR-1601 (MOORES CHAPEL RD).

CONTRACTOR CROWDER CONSTRUCTION COMPANY  
ADDRESS P.O. BOX 30007  
CHARLOTTE, NC 28230

BIDS OPENED MARCH 20, 2018  
CONTRACT EXECUTION 4/13/2018

STATE OF NORTH CAROLINA  
DEPARTMENT OF TRANSPORTATION  
RALEIGH, N.C.

PROPOSAL

DATE AND TIME OF BID OPENING: **MARCH 20, 2018 AT 2:00 PM**

CONTRACT ID C204116

WBS 53012.3.1

FEDERAL-AID NO. NHPIM-0085(037)

COUNTY MECKLENBURG

T.I.P. NO. I-5770, I-5796

MILES 7.809

ROUTE NO. I 85

LOCATION I-85 FROM CONC PVMT JOINT 0.3 MILES SOUTH OF NC-16 TO  
CONC PVMT JOINT SOUTH OF SR-1601 (MOORES CHAPEL RD).

TYPE OF WORK PAVEMENT REHABILITATION.

**NOTICE:**

ALL BIDDERS SHALL COMPLY WITH ALL APPLICABLE LAWS REGULATING THE PRACTICE OF GENERAL CONTRACTING AS CONTAINED IN CHAPTER 87 OF THE GENERAL STATUTES OF NORTH CAROLINA WHICH REQUIRES THE BIDDER TO BE LICENSED BY THE N.C. LICENSING BOARD FOR CONTRACTORS WHEN BIDDING ON ANY NON-FEDERAL AID PROJECT WHERE THE BID IS \$30,000 OR MORE, EXCEPT FOR CERTAIN SPECIALTY WORK AS DETERMINED BY THE LICENSING BOARD. BIDDERS SHALL ALSO COMPLY WITH ALL OTHER APPLICABLE LAWS REGULATING THE PRACTICES OF ELECTRICAL, PLUMBING, HEATING AND AIR CONDITIONING AND REFRIGERATION CONTRACTING AS CONTAINED IN CHAPTER 87 OF THE GENERAL STATUTES OF NORTH CAROLINA. NOTWITHSTANDING THESE LIMITATIONS ON BIDDING, THE BIDDER WHO IS AWARDED ANY FEDERAL - AID FUNDED PROJECT SHALL COMPLY WITH CHAPTER 87 OF THE GENERAL STATUTES OF NORTH CAROLINA FOR LICENSING REQUIREMENTS WITHIN 60 CALENDAR DAYS OF BID OPENING.

**BIDS WILL BE RECEIVED AS SHOWN BELOW:**

**THIS IS A ROADWAY PROPOSAL**

**5% BID BOND OR BID DEPOSIT REQUIRED**

---

**PROPOSAL FOR THE CONSTRUCTION OF  
CONTRACT No. C204116 IN MECKLENBURG COUNTY, NORTH CAROLINA**

Date \_\_\_\_\_ 20 \_\_\_\_\_

**DEPARTMENT OF TRANSPORTATION,  
RALEIGH, NORTH CAROLINA**

The Bidder has carefully examined the location of the proposed work to be known as Contract No. C204116 has carefully examined the plans and specifications, which are acknowledged to be part of the proposal, the special provisions, the proposal, the form of contract, and the forms of contract payment bond and contract performance bond; and thoroughly understands the stipulations, requirements and provisions. The undersigned bidder agrees to bound upon his execution of the bid and subsequent award to him by the Board of Transportation in accordance with this proposal to provide the necessary contract payment bond and contract performance bond within fourteen days after the written notice of award is received by him. The undersigned Bidder further agrees to provide all necessary machinery, tools, labor, and other means of construction; and to do all the work and to furnish all materials, except as otherwise noted, necessary to perform and complete the said contract in accordance with *the 2018 Standard Specifications for Roads and Structures* by the dates(s) specified in the Project Special Provisions and in accordance with the requirements of the Engineer, and at the unit or lump sum prices, as the case may be, for the various items given on the sheets contained herein.

The Bidder shall provide and furnish all the materials, machinery, implements, appliances and tools, and perform the work and required labor to construct and complete State Highway Contract No. C204116 in Mecklenburg County, for the unit or lump sum prices, as the case may be, bid by the Bidder in his bid and according to the proposal, plans, and specifications prepared by said Department, which proposal, plans, and specifications show the details covering this project, and hereby become a part of this contract.

The published volume entitled *North Carolina Department of Transportation, Raleigh, Standard Specifications for Roads and Structures, January 2018* with all amendments and supplements thereto, is by reference incorporated into and made a part of this contract; that, except as herein modified, all the construction and work included in this contract is to be done in accordance with the specifications contained in said volume, and amendments and supplements thereto, under the direction of the Engineer.

If the proposal is accepted and the award is made, the contract is valid only when signed either by the Contract Officer or such other person as may be designated by the Secretary to sign for the Department of Transportation. The conditions and provisions herein cannot be changed except over the signature of the said Contract Officer.

The quantities shown in the itemized proposal for the project are considered to be approximate only and are given as the basis for comparison of bids. The Department of Transportation may increase or decrease the quantity of any item or portion of the work as may be deemed necessary or expedient.

An increase or decrease in the quantity of an item will not be regarded as sufficient ground for an increase or decrease in the unit prices, nor in the time allowed for the completion of the work, except as provided for the contract.

Accompanying this bid is a bid bond secured by a corporate surety, or certified check payable to the order of the Department of Transportation, for five percent of the total bid price, which deposit is to be forfeited as liquidated damages in case this bid is accepted and the Bidder shall fail to provide the required payment and performance bonds with the Department of Transportation, under the condition of this proposal, within 14 calendar days after the written notice of award is received by him, as provided in the *Standard Specifications*; otherwise said deposit will be returned to the Bidder.



*State Contract Officer*

DocuSigned by:

*Ronald E. Davenport, Jr.*

F81B6038A47A442... 2/7/2018

**TABLE OF CONTENTS**

**COVER SHEET  
PROPOSAL SHEET**

**PROJECT SPECIAL PROVISIONS**

CONTRACT TIME AND LIQUIDATED DAMAGES: ..... G-1  
 INTERMEDIATE CONTRACT TIME NUMBER 1 AND LIQUIDATED DAMAGES:..... G-1  
 INTERMEDIATE CONTRACT TIME NUMBER 2 AND LIQUIDATED DAMAGES:..... G-2  
 INTERMEDIATE CONTRACT TIME NUMBER 3 AND LIQUIDATED DAMAGES:..... G-3  
 MAJOR CONTRACT ITEMS: ..... G-3  
 SPECIALTY ITEMS: ..... G-4  
 SCHEDULE OF ESTIMATED COMPLETION PROGRESS:..... G-4  
 DISADVANTAGED BUSINESS ENTERPRISE: ..... G-4  
 CERTIFICATION FOR FEDERAL-AID CONTRACTS: ..... G-17  
 U.S. DEPARTMENT OF TRANSPORTATION HOTLINE: ..... G-18  
 CARGO PREFERENCE ACT: ..... G-18  
 SUBSURFACE INFORMATION:..... G-18  
 MAINTENANCE OF THE PROJECT: ..... G-19  
 TWELVE MONTH GUARANTEE: ..... G-19  
 EROSION AND SEDIMENT CONTROL/STORMWATER CERTIFICATION: ..... G-20

ROADWAY ..... R-1

**STANDARD SPECIAL PROVISIONS**

AVAILABILITY FUNDS – TERMINATION OF CONTRACTS ..... SSP-1  
 ERRATA..... SSP-2  
 PLANT AND PEST QUARANTINES ..... SSP-3  
 MINORITY AND FEMALE EMPLOYMENT REQUIREMENTS ..... SSP-4  
 REQUIRED CONTRACT PROVISIONS FEDERAL-AID CONST. CONTRACTS ..... SSP-7  
 ON-THE-JOB TRAINING ..... SSP-16  
 MINIMUM WAGES ..... SSP-19

**UNIT PROJECT SPECIAL PROVISIONS**

TRAFFIC CONTROL ..... TC-1  
 EROSION CONTROL ..... EC-1  
 SLAB JACKING ..... SJ-1  
 STRUCTURE / CULVERTS..... BP-1

**PROPOSAL ITEM SHEET**

ITEM SHEET(S) (TAN SHEETS)

**PROJECT SPECIAL PROVISIONS****GENERAL****CONTRACT TIME AND LIQUIDATED DAMAGES:**

(7-1-95) (Rev. 12-18-07)

108

SP1 G10 A

The date of availability for this contract is **April 30, 2018**.

The completion date for this contract is **September 1, 2019**.

Except where otherwise provided by the contract, observation periods required by the contract will not be a part of the work to be completed by the completion date and/or intermediate contract times stated in the contract. The acceptable completion of the observation periods that extend beyond the final completion date shall be a part of the work covered by the performance and payment bonds.

The liquidated damages for this contract are **One Thousand Five Hundred Dollars (\$ 1,500.00)** per calendar day.

**INTERMEDIATE CONTRACT TIME NUMBER 1 AND LIQUIDATED DAMAGES:**

(2-20-07)

108

SP1 G14 A

The Contractor shall complete the required work of installing, maintaining, and removing the traffic control devices for lane closures and restoring traffic to the existing traffic pattern. The Contractor shall not close or narrow a lane of traffic on **I-85 (one lane)** during the following time restrictions:

**DAY AND TIME RESTRICTIONS**

**Monday thru Sunday  
6:00 A.M. to 8:00 P.M.**

In addition, the Contractor shall not close or narrow a lane of traffic on **I-85, including any ramp and/or loop** detain and/or alter the traffic flow on or during holidays, holiday weekends, special events, or any other time when traffic is unusually heavy, including the following schedules:

**HOLIDAY AND HOLIDAY WEEKEND LANE CLOSURE RESTRICTIONS**

1. For **unexpected occurrence** that creates unusually high traffic volumes, as directed by the Engineer.
2. For **New Year's Day**, between the hours of **6:00 AM** December 31st and **8:00 PM** January 2<sup>nd</sup>. If New Year's Day is on a Friday, Saturday, Sunday or Monday, then until **8:00 PM** the following Tuesday.
3. For **Easter**, between the hours of **6:00 AM** Thursday and **8:00 PM** Monday.
4. For **Memorial Day**, between the hours of **6:00 AM** Friday and **8:00 PM** Tuesday.

5. For **Independence Day**, between the hours of **6:00 AM** the day before Independence Day and **8:00 PM** the day after Independence Day.  
  
If **Independence Day** is on a Friday, Saturday, Sunday or Monday, then between the hours of **6:00 AM** the Thursday before Independence Day and **8:00 PM** the Tuesday after Independence Day.
6. For **Labor Day**, between the hours of **6:00 AM** Friday and **8:00 PM** Tuesday.
7. For **Thanksgiving**, between the hours of **6:00 AM** Tuesday and **8:00 PM** Monday.
8. For **Christmas**, between the hours of **6:00 AM** the Friday before the week of Christmas Day and **8:00 PM** the following Tuesday after the week of Christmas Day.
9. For **Spring and Fall NASCAR Events** occurring at **Charlotte Motor Speedway** and **Drag Race Events** at **Z Max Dragway** between 6:00 AM the Thursday before the week of the event until 8:00 PM the Monday after the event, or as directed by the Engineer.
10. For any **NFL Football Game** at **Bank of America Stadium**, or any event at the **Spectrum Center and/or BB&T Ballpark**, from three (3) hours before the start of the Event and three (3) hours after the end of the Event.
11. For any event at the **US National Whitewater Center**, occurring in Charlotte, from three (3) hours before the start of the Event and three (3) hours after the end of the Event.

Holidays and holiday weekends shall include New Year's, Easter, Memorial Day, Independence Day, Labor Day, Thanksgiving, and Christmas. The Contractor shall schedule his work so that lane closures will not be required during these periods, unless otherwise directed by the Engineer.

The time of availability for this intermediate contract work shall be the time the Contractor begins to install all traffic control devices for lane closures according to the time restrictions listed herein.

The completion time for this intermediate contract work shall be the time the Contractor is required to complete the removal of all traffic control devices for lane closures according to the time restrictions stated above and place traffic in the existing traffic pattern.

The liquidated damages are **One Thousand Two Hundred Fifty Dollars (\$ 1,250.00)** per fifteen **(15)** minute time period.

**INTERMEDIATE CONTRACT TIME NUMBER 2 AND LIQUIDATED DAMAGES:**

(2-20-07)

108

SP1 G14 A

The Contractor shall complete the required work of installing, maintaining and removing the traffic control devices for lane closures and restoring traffic to the existing traffic pattern. The Contractor shall not close or narrow a lane of traffic on **I-85 (two lanes)** during the following time restrictions:

DAY AND TIME RESTRICTIONS

**Monday thru Sunday  
6:00 A.M. to 10:00 P.M.**

The time of availability for this intermediate contract time will be the time the Contractor begins to install traffic control devices required for the lane closures according to the time restrictions stated herein.

The completion time for this intermediate contract time will be the time the Contractor is required to complete the removal of traffic control devices required for the lane closures according to the time restrictions stated herein and restore traffic to the existing traffic pattern.

The liquidated damages are **Two Thousand Five Hundred Dollars (\$ 2,500.00)** per fifteen (15) minute time period.

**INTERMEDIATE CONTRACT TIME NUMBER 3 AND LIQUIDATED DAMAGES:**

(2-20-07)

108

SP1 G14 D

The Contractor shall complete the required work of installing, maintaining and removing the traffic control devices for **ramp** closures and restoring traffic to the existing traffic pattern. The Contractor shall not close **Any Ramps** during the following time restrictions:

DAY AND TIME RESTRICTIONS

**Monday thru Sunday  
6:00 a.m. to 10:00 p.m.**

The time of availability for this intermediate contract time will be the time the Contractor begins to install traffic control devices required for road closures according to the time restrictions stated herein.

The completion time for this intermediate contract time will be the time the Contractor is required to complete the removal of traffic control devices required for the road closures according to the time restrictions stated herein and restore traffic to the existing traffic pattern.

The liquidated damages are **Five Hundred Dollars (\$ 500.00)** per fifteen (15) minute time period.

**MAJOR CONTRACT ITEMS:**

(2-19-02)

104

SP1 G28

The following listed items are the major contract items for this contract (see Article 104-5 of the *2018 Standard Specifications*):

<b>Line #</b>	<b>Description</b>
9 —	Diamond Grinding PCC Pavement

**SPECIALTY ITEMS:**

(7-1-95)(Rev. 1-17-12)

108-6

SP1 G37

Items listed below will be the specialty items for this contract (see Article 108-6 of the 2018 Standard Specifications).

<b>Line #</b>	<b>Description</b>
8	Joint Construction, Repair and Sealing
9	Diamond Grinding PCC Pavement
17-18, 22-23, & 27	Long-Life Pavement Markings
28-29	Permanent Pavement Markers
31-32	Erosion Control

**SCHEDULE OF ESTIMATED COMPLETION PROGRESS:**

(7-15-08) (Rev. 5-16-17)

108-2

SP1 G58

The Contractor's attention is directed to the Standard Special Provision entitled *Availability of Funds Termination of Contracts* included elsewhere in this proposal. The Department of Transportation's schedule of estimated completion progress for this project as required by that Standard Special Provision is as follows:

	<b><u>Fiscal Year</u></b>	<b><u>Progress (% of Dollar Value)</u></b>
2018	(7/01/17 - 6/30/18)	<b>19%</b> of Total Amount Bid
2019	(7/01/18 - 6/30/19)	<b>75%</b> of Total Amount Bid
2020	(7/01/19 - 6/30/20)	<b>6%</b> of Total Amount Bid

The Contractor shall also furnish his own progress schedule in accordance with Article 108-2 of the 2018 Standard Specifications. Any acceleration of the progress as shown by the Contractor's progress schedule over the progress as shown above shall be subject to the approval of the Engineer.

**DISADVANTAGED BUSINESS ENTERPRISE:**

(10-16-07)(Rev. 1-17-17)

102-15(J)

SP1 G61

**Description**

The purpose of this Special Provision is to carry out the U.S. Department of Transportation's policy of ensuring nondiscrimination in the award and administration of contracts financed in whole or in part with Federal funds. This provision is guided by 49 CFR Part 26.

**Definitions**

*Additional DBE Subcontractors* - Any DBE submitted at the time of bid that will not be used to meet the DBE goal. No submittal of a Letter of Intent is required.

*Committed DBE Subcontractor* - Any DBE submitted at the time of bid that is being used to meet the DBE goal by submission of a Letter of Intent. Or any DBE used as a replacement for a previously committed DBE firm.

*Contract Goal Requirement* - The approved DBE participation at time of award, but not greater than the advertised contract goal.



*DBE Goal* - A portion of the total contract, expressed as a percentage, that is to be performed by committed DBE subcontractor(s).

*Disadvantaged Business Enterprise (DBE)* - A firm certified as a Disadvantaged Business Enterprise through the North Carolina Unified Certification Program.

*Goal Confirmation Letter* - Written documentation from the Department to the bidder confirming the Contractor's approved, committed DBE participation along with a listing of the committed DBE firms.

*Manufacturer* - A firm that operates or maintains a factory or establishment that produces on the premises, the materials or supplies obtained by the Contractor.

*Regular Dealer* - A firm that owns, operates, or maintains a store, warehouse, or other establishment in which the materials or supplies required for the performance of the contract are bought, kept in stock, and regularly sold to the public in the usual course of business. A regular dealer engages in, as its principal business and in its own name, the purchase and sale or lease of the products in question. A regular dealer in such bulk items as steel, cement, gravel, stone, and petroleum products need not keep such products in stock, if it owns and operates distribution equipment for the products. Brokers and packagers are not regarded as manufacturers or regular dealers within the meaning of this section.

*North Carolina Unified Certification Program (NCUCP)* - A program that provides comprehensive services and information to applicants for DBE certification, such that an applicant is required to apply only once for a DBE certification that will be honored by all recipients of USDOT funds in the state and not limited to the Department of Transportation only. The Certification Program is in accordance with 49 CFR Part 26.

*United States Department of Transportation (USDOT)* - Federal agency responsible for issuing regulations (49 CFR Part 26) and official guidance for the DBE program.

### **Forms and Websites Referenced in this Provision**

*DBE Payment Tracking System* - On-line system in which the Contractor enters the payments made to DBE subcontractors who have performed work on the project.  
<https://apps.dot.state.nc.us/Vendor/PaymentTracking/>

*DBE-IS Subcontractor Payment Information* - Form for reporting the payments made to all DBE firms working on the project. This form is for paper bid projects only.  
<https://connect.ncdot.gov/business/Turnpike/Documents/Form%20DBE-IS%20Subcontractor%20Payment%20Information.pdf>

*RF-1 DBE Replacement Request Form* - Form for replacing a committed DBE.  
<http://connect.ncdot.gov/projects/construction/Construction%20Forms/DBE%20MBE%20WBE%20Replacement%20Request%20Form.pdf>

*SAF Subcontract Approval Form* - Form required for approval to sublet the contract.  
<http://connect.ncdot.gov/projects/construction/Construction%20Forms/Subcontract%20Approval%20Form%20Rev.%202012.zip>

*JC-1 Joint Check Notification Form* - Form and procedures for joint check notification. The form acts as a written joint check agreement among the parties providing full and prompt disclosure of the expected use of joint checks.

<http://connect.ncdot.gov/projects/construction/Construction%20Forms/Joint%20Check%20Notification%20Form.pdf>

*Letter of Intent* - Form signed by the Contractor and the DBE subcontractor, manufacturer or regular dealer that affirms that a portion of said contract is going to be performed by the signed DBE for the amount listed at the time of bid.

<http://connect.ncdot.gov/letting/LetCentral/Letter%20of%20Intent%20to%20Perform%20as%20a%20Subcontractor.pdf>

*Listing of DBE Subcontractors Form* - Form for entering DBE subcontractors on a project that will meet this DBE goal. This form is for paper bids only.

[http://connect.ncdot.gov/municipalities/Bid%20Proposals%20for%20LGA%20Content/08%20DBE%20Subcontractors%20\(Federal\).docx](http://connect.ncdot.gov/municipalities/Bid%20Proposals%20for%20LGA%20Content/08%20DBE%20Subcontractors%20(Federal).docx)

*Subcontractor Quote Comparison Sheet* - Spreadsheet for showing all subcontractor quotes in the work areas where DBEs quoted on the project. This sheet is submitted with good faith effort packages.

<http://connect.ncdot.gov/business/SmallBusiness/Documents/DBE%20Subcontractor%20Quote%20Comparison%20Example.xls>

## **DBE Goal**

The following DBE goal for participation by Disadvantaged Business Enterprises is established for this contract:

Disadvantaged Business Enterprises **10.0** %

- (A) *If the DBE goal is more than zero*, the Contractor shall exercise all necessary and reasonable steps to ensure that DBEs participate in at least the percent of the contract as set forth above as the DBE goal.
- (B) *If the DBE goal is zero*, the Contractor shall make an effort to recruit and use DBEs during the performance of the contract. Any DBE participation obtained shall be reported to the Department.

## **Directory of Transportation Firms (Directory)**

Real-time information is available about firms doing business with the Department and firms that are certified through NCUCP in the Directory of Transportation Firms. Only firms identified in the Directory as DBE certified shall be used to meet the DBE goal. The Directory can be found at the following link. [https:// www.ebs.nc.gov/VendorDirectory/default.html](https://www.ebs.nc.gov/VendorDirectory/default.html)

The listing of an individual firm in the directory shall not be construed as an endorsement of the firm's capability to perform certain work.

### **Listing of DBE Subcontractors**

At the time of bid, bidders shall submit all DBE participation that they anticipate to use during the life of the contract. Only those identified to meet the DBE goal will be considered committed, even though the listing shall include both committed DBE subcontractors and additional DBE subcontractors. Additional DBE subcontractor participation submitted at the time of bid will be used toward the Department's overall race-neutral goal. Only those firms with current DBE certification at the time of bid opening will be acceptable for listing in the bidder's submittal of DBE participation. The Contractor shall indicate the following required information:

#### (A) Electronic Bids

Bidders shall submit a listing of DBE participation in the appropriate section of Expedite, the bidding software of Bid Express®.

- (1) Submit the names and addresses of DBE firms identified to participate in the contract. If the bidder uses the updated listing of DBE firms shown in Expedite, the bidder may use the dropdown menu to access the name and address of the DBE firm.
- (2) Submit the contract line numbers of work to be performed by each DBE firm. When no figures or firms are entered, the bidder will be considered to have no DBE participation.
- (3) The bidder shall be responsible for ensuring that the DBE is certified at the time of bid by checking the Directory of Transportation Firms. If the firm is not certified at the time of the bid-letting, that DBE's participation will not count towards achieving the DBE goal.

#### (B) Paper Bids

- (1) *If the DBE goal is more than zero,*
  - (a) Bidders, at the time the bid proposal is submitted, shall submit a listing of *DBE* participation, including the names and addresses on *Listing of DBE Subcontractors* contained elsewhere in the contract documents in order for the bid to be considered responsive. Bidders shall indicate the total dollar value of the DBE participation for the contract.
  - (b) If bidders have no DBE participation, they shall indicate this on the *Listing of DBE Subcontractors* by entering the word "None" or the number "0." This form shall be completed in its entirety. **Blank forms will not be deemed to represent zero participation.** Bids submitted that do not have DBE participation indicated on the appropriate form will not be read

publicly during the opening of bids. The Department will not consider these bids for award and the proposal will be rejected.

- (c) The bidder shall be responsible for ensuring that the DBE is certified at the time of bid by checking the Directory of Transportation Firms. If the firm is not certified at the time of the bid-letting, that DBE's participation will not count towards achieving the corresponding goal.
- (2) *If the DBE goal is zero*, entries on the *Listing of DBE Subcontractors* are not required for the zero goal, however any DBE participation that is achieved during the project shall be reported in accordance with requirements contained elsewhere in the special provision.

### **DBE Prime Contractor**

When a certified DBE firm bids on a contract that contains a DBE goal, the DBE firm is responsible for meeting the goal or making good faith efforts to meet the goal, just like any other bidder. In most cases, a DBE bidder on a contract will meet the DBE goal by virtue of the work it performs on the contract with its own forces. However, all the work that is performed by the DBE bidder and any other DBE subcontractors will count toward the DBE goal. The DBE bidder shall list itself along with any DBE subcontractors, if any, in order to receive credit toward the DBE goal.

For example, if the DBE goal is 45% and the DBE bidder will only perform 40% of the contract work, the prime will list itself at 40%, and the additional 5% shall be obtained through additional DBE participation with DBE subcontractors or documented through a good faith effort.

DBE prime contractors shall also follow Sections A and B listed under *Listing of DBE Subcontractor* just as a non-DBE bidder would.

### **Written Documentation – Letter of Intent**

The bidder shall submit written documentation for each DBE that will be used to meet the DBE goal of the contract, indicating the bidder's commitment to use the DBE in the contract. This documentation shall be submitted on the Department's form titled *Letter of Intent*.

The documentation shall be received in the office of the State Contractor Utilization Engineer or at DBE@ncdot.gov no later than 10:00 a.m. of the sixth calendar day following opening of bids, unless the sixth day falls on an official state holiday. In that situation, it is due in the office of the State Contractor Utilization Engineer no later than 10:00 a.m. on the next official state business day.

If the bidder fails to submit the Letter of Intent from each committed DBE to be used toward the DBE goal, or if the form is incomplete (i.e. both signatures are not present), the DBE participation will not count toward meeting the DBE goal. If the lack of this participation drops the commitment below the DBE goal, the Contractor shall submit evidence of good faith efforts, completed in its entirety, to the State Contractor Utilization Engineer or DBE@ncdot.gov no later than 10:00 a.m. on the eighth calendar day following opening of bids, unless the eighth day falls on an official state

holiday. In that situation, it is due in the office of the State Contractor Utilization Engineer no later than 10:00 a.m. on the next official state business day.

### **Submission of Good Faith Effort**

If the bidder fails to meet or exceed the DBE goal, the apparent lowest responsive bidder shall submit to the Department documentation of adequate good faith efforts made to reach the DBE goal.

A hard copy and an electronic copy of this information shall be received in the office of the State Contractor Utilization Engineer or at DBE@ncdot.gov no later than 10:00 a.m. on the sixth calendar day following opening of bids unless the sixth day falls on an official state holiday. In that situation, it is due in the office of the State Contractor Utilization Engineer no later than 10:00 a.m. on the next official state business day. If the contractor cannot send the information electronically, then one complete set and 9 copies of this information shall be received under the same time constraints above.

Note: Where the information submitted includes repetitious solicitation letters, it will be acceptable to submit a representative letter along with a distribution list of the firms that were solicited. Documentation of DBE quotations shall be a part of the good faith effort submittal. This documentation may include written subcontractor quotations, telephone log notations of verbal quotations, or other types of quotation documentation.

### **Consideration of Good Faith Effort for Projects with DBE Goals More Than Zero**

Adequate good faith efforts mean that the bidder took all necessary and reasonable steps to achieve the goal which, by their scope, intensity, and appropriateness, could reasonably be expected to obtain sufficient DBE participation. Adequate good faith efforts also mean that the bidder actively and aggressively sought DBE participation. Mere *pro forma* efforts are not considered good faith efforts.

The Department will consider the quality, quantity, and intensity of the different kinds of efforts a bidder has made. Listed below are examples of the types of actions a bidder will take in making a good faith effort to meet the goal and are not intended to be exclusive or exhaustive, nor is it intended to be a mandatory checklist.

- (A) Soliciting through all reasonable and available means (e.g. attendance at pre-bid meetings, advertising, written notices, use of verifiable electronic means through the use of the NCDOT Directory of Transportation Firms) the interest of all certified DBEs who have the capability to perform the work of the contract. The bidder must solicit this interest within at least 10 days prior to bid opening to allow the DBEs to respond to the solicitation. Solicitation shall provide the opportunity to DBEs within the Division and surrounding Divisions where the project is located. The bidder must determine with certainty if the DBEs are interested by taking appropriate steps to follow up initial solicitations.

- (B) Selecting portions of the work to be performed by DBEs in order to increase the likelihood that the DBE goals will be achieved.
- (1) Where appropriate, break out contract work items into economically feasible units to facilitate DBE participation, even when the prime contractor might otherwise prefer to perform these work items with its own forces.
  - (2) Negotiate with subcontractors to assume part of the responsibility to meet the contract DBE goal when the work to be sublet includes potential for DBE participation (2<sup>nd</sup> and 3<sup>rd</sup> tier subcontractors).
- (C) Providing interested DBEs with adequate information about the plans, specifications, and requirements of the contract in a timely manner to assist them in responding to a solicitation.
- (D) (1) Negotiating in good faith with interested DBEs. It is the bidder's responsibility to make a portion of the work available to DBE subcontractors and suppliers and to select those portions of the work or material needs consistent with the available DBE subcontractors and suppliers, so as to facilitate DBE participation. Evidence of such negotiation includes the names, addresses, and telephone numbers of DBEs that were considered; a description of the information provided regarding the plans and specifications for the work selected for subcontracting; and evidence as to why additional agreements could not be reached for DBEs to perform the work.
- (2) A bidder using good business judgment would consider a number of factors in negotiating with subcontractors, including DBE subcontractors, and would take a firm's price and capabilities as well as contract goals into consideration. However, the fact that there may be some additional costs involved in finding and using DBEs is not in itself sufficient reason for a bidder's failure to meet the contract DBE goal, as long as such costs are reasonable. Also, the ability or desire of a prime contractor to perform the work of a contract with its own organization does not relieve the bidder of the responsibility to make good faith efforts. Bidding contractors are not, however, required to accept higher quotes from DBEs if the price difference is excessive or unreasonable.
- (E) Not rejecting DBEs as being unqualified without sound reasons based on a thorough investigation of their capabilities. The bidder's standing within its industry, membership in specific groups, organizations, or associates and political or social affiliations (for example, union vs. non-union employee status) are not legitimate causes for the rejection or non-solicitation of bids in the bidder's efforts to meet the project goal.
- (F) Making efforts to assist interested DBEs in obtaining bonding, lines of credit, or insurance as required by the recipient or bidder.
- (G) Making efforts to assist interested DBEs in obtaining necessary equipment, supplies, materials, or related assistance or services.

- (H) Effectively using the services of available minority/women community organizations; minority/women contractors' groups; Federal, State, and local minority/women business assistance offices; and other organizations as allowed on a case-by-case basis to provide assistance in the recruitment and placement of DBEs. Contact within 7 days from the bid opening the Business Opportunity and Work Force Development Unit at DBE@ncdot.gov to give notification of the bidder's inability to get DBE quotes.
- (I) Any other evidence that the bidder submits which shows that the bidder has made reasonable good faith efforts to meet the DBE goal.

In addition, the Department may take into account the following:

- (1) Whether the bidder's documentation reflects a clear and realistic plan for achieving the DBE goal.
- (2) The bidders' past performance in meeting the DBE goals.
- (3) The performance of other bidders in meeting the DBE goal. For example, when the apparent successful bidder fails to meet the DBE goal, but others meet it, you may reasonably raise the question of whether, with additional reasonable efforts the apparent successful bidder could have met the goal. If the apparent successful bidder fails to meet the DBE goal, but meets or exceeds the average DBE participation obtained by other bidders, the Department may view this, in conjunction with other factors, as evidence of the apparent successful bidder having made a good faith effort.

If the Department does not award the contract to the apparent lowest responsive bidder, the Department reserves the right to award the contract to the next lowest responsive bidder that can satisfy to the Department that the DBE goal can be met or that an adequate good faith effort has been made to meet the DBE goal.

### **Non-Good Faith Appeal**

The State Contractual Services Engineer will notify the contractor verbally and in writing of non-good faith. A contractor may appeal a determination of non-good faith made by the Goal Compliance Committee. If a contractor wishes to appeal the determination made by the Committee, they shall provide written notification to the State Contractual Services Engineer or at DBE@ncdot.gov. The appeal shall be made within 2 business days of notification of the determination of non-good faith.

### **Counting DBE Participation Toward Meeting DBE Goal**

- (A) Participation

The total dollar value of the participation by a committed DBE will be counted toward the contract goal requirement. The total dollar value of participation by a committed DBE will be based upon the value of work actually performed by the DBE and the actual payments to DBE firms by the Contractor.

## (B) Joint Checks

Prior notification of joint check use shall be required when counting DBE participation for services or purchases that involves the use of a joint check. Notification shall be through submission of Form JC-1 (*Joint Check Notification Form*) and the use of joint checks shall be in accordance with the Department's Joint Check Procedures.

## (C) Subcontracts (Non-Trucking)

A DBE may enter into subcontracts. Work that a DBE subcontracts to another DBE firm may be counted toward the contract goal requirement. Work that a DBE subcontracts to a non-DBE firm does not count toward the contract goal requirement. If a DBE contractor or subcontractor subcontracts a significantly greater portion of the work of the contract than would be expected on the basis of standard industry practices, it shall be presumed that the DBE is not performing a commercially useful function. The DBE may present evidence to rebut this presumption to the Department. The Department's decision on the rebuttal of this presumption is subject to review by the Federal Highway Administration but is not administratively appealable to USDOT.

## (D) Joint Venture

When a DBE performs as a participant in a joint venture, the Contractor may count toward its contract goal requirement a portion of the total value of participation with the DBE in the joint venture, that portion of the total dollar value being a distinct clearly defined portion of work that the DBE performs with its forces.

## (E) Suppliers

A contractor may count toward its DBE requirement 60 percent of its expenditures for materials and supplies required to complete the contract and obtained from a DBE regular dealer and 100 percent of such expenditures from a DBE manufacturer.

## (F) Manufacturers and Regular Dealers

A contractor may count toward its DBE requirement the following expenditures to DBE firms that are not manufacturers or regular dealers:

- (1) The fees or commissions charged by a DBE firm for providing a *bona fide* service, such as professional, technical, consultant, or managerial services, or for providing bonds or insurance specifically required for the performance of a DOT-assisted contract, provided the fees or commissions are determined to be reasonable and not excessive as compared with fees and commissions customarily allowed for similar services.
- (2) With respect to materials or supplies purchased from a DBE, which is neither a manufacturer nor a regular dealer, count the entire amount of fees or commissions charged for assistance in the procurement of the materials and supplies, or fees or



transportation charges for the delivery of materials or supplies required on a job site (but not the cost of the materials and supplies themselves), provided the fees are determined to be reasonable and not excessive as compared with fees customarily allowed for similar services.

### **Commercially Useful Function**

#### **(A) DBE Utilization**

The Contractor may count toward its contract goal requirement only expenditures to DBEs that perform a commercially useful function in the work of a contract. A DBE performs a commercially useful function when it is responsible for execution of the work of the contract and is carrying out its responsibilities by actually performing, managing, and supervising the work involved. To perform a commercially useful function, the DBE shall also be responsible with respect to materials and supplies used on the contract, for negotiating price, determining quality and quantity, ordering the material and installing (where applicable) and paying for the material itself. To determine whether a DBE is performing a commercially useful function, the Department will evaluate the amount of work subcontracted, industry practices, whether the amount the firm is to be paid under the contract is commensurate with the work it is actually performing and the DBE credit claimed for its performance of the work, and any other relevant factors.

#### **(B) DBE Utilization in Trucking**

The following factors will be used to determine if a DBE trucking firm is performing a commercially useful function:

- (1) The DBE shall be responsible for the management and supervision of the entire trucking operation for which it is responsible on a particular contract, and there shall not be a contrived arrangement for the purpose of meeting DBE goals.
- (2) The DBE shall itself own and operate at least one fully licensed, insured, and operational truck used on the contract.
- (3) The DBE receives credit for the total value of the transportation services it provides on the contract using trucks it owns, insures, and operates using drivers it employs.
- (4) The DBE may subcontract the work to another DBE firm, including an owner-operator who is certified as a DBE. The DBE who subcontracts work to another DBE receives credit for the total value of the transportation services the subcontracted DBE provides on the contract.
- (5) The DBE may also subcontract the work to a non-DBE firm, including from an owner-operator. The DBE who subcontracts the work to a non-DBE is entitled to credit for the total value of transportation services provided by the non-DBE subcontractor not to exceed the value of transportation services provided by DBE-owned trucks on the contract. Additional participation by non-DBE subcontractors receives credit only for the fee or commission it receives as a result

of the subcontract arrangement. The value of services performed under subcontract agreements between the DBE and the Contractor will not count towards the DBE contract requirement.

- (6) A DBE may lease truck(s) from an established equipment leasing business open to the general public. The lease must indicate that the DBE has exclusive use of and control over the truck. This requirement does not preclude the leased truck from working for others during the term of the lease with the consent of the DBE, so long as the lease gives the DBE absolute priority for use of the leased truck. This type of lease may count toward the DBE's credit as long as the driver is under the DBE's payroll.
- (7) Subcontracted/leased trucks shall display clearly on the dashboard the name of the DBE that they are subcontracted/leased to and their own company name if it is not identified on the truck itself. Magnetic door signs are not permitted.

### **DBE Replacement**

When a Contractor has relied on a commitment to a DBE firm (or an approved substitute DBE firm) to meet all or part of a contract goal requirement, the contractor shall not terminate the DBE for convenience. This includes, but is not limited to, instances in which the Contractor seeks to perform the work of the terminated subcontractor with another DBE subcontractor, a non-DBE subcontractor, or with the Contractor's own forces or those of an affiliate. A DBE may only be terminated after receiving the Engineer's written approval based upon a finding of good cause for the termination. The prime contractor must give the DBE firm five (5) calendar days to respond to the prime contractor's notice of termination and advise the prime contractor and the Department of the reasons, if any, why the firm objects to the proposed termination of its subcontract and why the Department should not approve the action.

All requests for replacement of a committed DBE firm shall be submitted to the Engineer for approval on Form RF-1 (*DBE Replacement Request*). If the Contractor fails to follow this procedure, the Contractor may be disqualified from further bidding for a period of up to 6 months.

The Contractor shall comply with the following for replacement of a committed DBE:

#### **(A) Performance Related Replacement**

When a committed DBE is terminated for good cause as stated above, an additional DBE that was submitted at the time of bid may be used to fulfill the DBE commitment. A good faith effort will only be required for removing a committed DBE if there were no additional DBEs submitted at the time of bid to cover the same amount of work as the DBE that was terminated.

If a replacement DBE is not found that can perform at least the same amount of work as the terminated DBE, the Contractor shall submit a good faith effort documenting the steps taken. Such documentation shall include, but not be limited to, the following:

- (1) Copies of written notification to DBEs that their interest is solicited in contracting the work defaulted by the previous DBE or in subcontracting other items of work in the contract.
  - (2) Efforts to negotiate with DBEs for specific subbids including, at a minimum:
    - (a) The names, addresses, and telephone numbers of DBEs who were contacted.
    - (b) A description of the information provided to DBEs regarding the plans and specifications for portions of the work to be performed.
  - (3) A list of reasons why DBE quotes were not accepted.
  - (4) Efforts made to assist the DBEs contacted, if needed, in obtaining bonding or insurance required by the Contractor.
- (B) Decertification Replacement
- (1) When a committed DBE is decertified by the Department after the SAF (*Subcontract Approval Form*) has been received by the Department, the Department will not require the Contractor to solicit replacement DBE participation equal to the remaining work to be performed by the decertified firm. The participation equal to the remaining work performed by the decertified firm will count toward the contract goal requirement.
  - (2) When a committed DBE is decertified prior to the Department receiving the SAF (*Subcontract Approval Form*) for the named DBE firm, the Contractor shall take all necessary and reasonable steps to replace the DBE subcontractor with another DBE subcontractor to perform at least the same amount of work to meet the DBE goal requirement. If a DBE firm is not found to do the same amount of work, a good faith effort must be submitted to NCDOT (see A herein for required documentation).

### **Changes in the Work**

When the Engineer makes changes that result in the reduction or elimination of work to be performed by a committed DBE, the Contractor will not be required to seek additional participation. When the Engineer makes changes that result in additional work to be performed by a DBE based upon the Contractor's commitment, the DBE shall participate in additional work to the same extent as the DBE participated in the original contract work.

When the Engineer makes changes that result in extra work, which has more than a minimal impact on the contract amount, the Contractor shall seek additional participation by DBEs unless otherwise approved by the Engineer.

When the Engineer makes changes that result in an alteration of plans or details of construction, and a portion or all of the work had been expected to be performed by a committed DBE, the Contractor shall seek participation by DBEs unless otherwise approved by the Engineer.

When the Contractor requests changes in the work that result in the reduction or elimination of work that the Contractor committed to be performed by a DBE, the Contractor shall seek additional participation by DBEs equal to the reduced DBE participation caused by the changes.

### **Reports and Documentation**

A SAF (*Subcontract Approval Form*) shall be submitted for all work which is to be performed by a DBE subcontractor. The Department reserves the right to require copies of actual subcontract agreements involving DBE subcontractors.

When using transportation services to meet the contract commitment, the Contractor shall submit a proposed trucking plan in addition to the SAF. The plan shall be submitted prior to beginning construction on the project. The plan shall include the names of all trucking firms proposed for use, their certification type(s), the number of trucks owned by the firm, as well as the individual truck identification numbers, and the line item(s) being performed.

Within 30 calendar days of entering into an agreement with a DBE for materials, supplies or services, not otherwise documented by the SAF as specified above, the Contractor shall furnish the Engineer a copy of the agreement. The documentation shall also indicate the percentage (60% or 100%) of expenditures claimed for DBE credit.

### **Reporting Disadvantaged Business Enterprise Participation**

The Contractor shall provide the Engineer with an accounting of payments made to all DBE firms, including material suppliers and contractors at all levels (prime, subcontractor, or second tier subcontractor). This accounting shall be furnished to the Engineer for any given month by the end of the following month. Failure to submit this information accordingly may result in the following action:

- (A) Withholding of money due in the next partial pay estimate; or
- (B) Removal of an approved contractor from the prequalified bidders' list or the removal of other entities from the approved subcontractors list.

While each contractor (prime, subcontractor, 2nd tier subcontractor) is responsible for accurate accounting of payments to DBEs, it shall be the prime contractor's responsibility to report all monthly and final payment information in the correct reporting manner.

Failure on the part of the Contractor to submit the required information in the time frame specified may result in the disqualification of that contractor and any affiliate companies from further bidding until the required information is submitted.

Failure on the part of any subcontractor to submit the required information in the time frame specified may result in the disqualification of that contractor and any affiliate companies from being approved for work on future DOT projects until the required information is submitted.

Contractors reporting transportation services provided by non-DBE lessees shall evaluate the value of services provided during the month of the reporting period only.

At any time, the Engineer can request written verification of subcontractor payments.

The Contractor shall report the accounting of payments through the Department's DBE Payment Tracking System.

### **Failure to Meet Contract Requirements**

Failure to meet contract requirements in accordance with Subarticle 102-15(J) of the *2018 Standard Specifications* may be cause to disqualify the Contractor.

### **CERTIFICATION FOR FEDERAL-AID CONTRACTS:**

(3-21-90)

SP1 G85

The prospective participant certifies, by signing and submitting this bid or proposal, to the best of his or her knowledge and belief, that:

- (A) No Federal appropriated funds have been paid or will be paid, by or on behalf of the undersigned, to any person for influencing or attempting to influence an officer or employee of any Federal agency, a Member of Congress, an officer or employee of Congress, or an employee of a Member of Congress in connection with the awarding of any Federal contract, the making of any Federal grant, the making of any Federal loan, the entering into of any cooperative agreement, and the extension, continuation, renewal, amendment, or modification of any Federal contract, grant, loan, or cooperative agreement.
- (B) If any funds other than Federal appropriated funds have been paid or will be paid to any person for influencing or attempting to influence an officer or employee of any Federal agency, a Member of Congress, an officer or employee of Congress, or an employee of a Member of Congress in connection with this Federal contract, grant, loan, or cooperative agreement, the undersigned shall complete and submit Standard Form-LLL, *Disclosure Form to Report Lobbying*, in accordance with its instructions.

This certification is a material representation of fact upon which reliance was placed when this transaction was made or entered into. Submission of this certification is a prerequisite for making or entering into this transaction imposed by *Section 1352, Title 31, U.S. Code*. Any person who fails to file the required certification shall be subject to a civil penalty of not less than \$10,000 and not more than \$100,000 for each such failure.

The prospective participant also agrees by submitting his or her bid or proposal that he or she shall require that the language of this certification be included in all lower tier subcontracts, which exceed \$100,000 and that all such subrecipients shall certify and disclose accordingly.

**U.S. DEPARTMENT OF TRANSPORTATION HOTLINE:**

(11-22-94)

108-5

SP1 G100

To report bid rigging activities call: **1-800-424-9071**

The U.S. Department of Transportation (DOT) operates the above toll-free hotline Monday through Friday, 8:00 a.m. to 5:00 p.m. eastern time. Anyone with knowledge of possible bid rigging, bidder collusion, or other fraudulent activities should use the hotline to report such activities.

The hotline is part of the DOT's continuing effort to identify and investigate highway construction contract fraud and abuse is operated under the direction of the DOT Inspector General. All information will be treated confidentially and caller anonymity will be respected.

**CARGO PREFERENCE ACT:**

(2-16-16)

Privately owned United States-flag commercial vessels transporting cargoes are subject to the Cargo Preference Act (CPA) of 1954 requirements and regulations found in 46 CFR 381.7. Contractors are directed to clause (b) of 46 CFR 381.7 as follows:

(b) Contractor and Subcontractor Clauses. "Use of United States-flag vessels: The contractor agrees-

" (1) To utilize privately owned United States-flag commercial vessels to ship at least 50 percent of the gross tonnage (computed separately for dry bulk carriers, dry cargo liners, and tankers) involved, whenever shipping any equipment, material, or commodities pursuant to this contract, to the extent such vessels are available at fair and reasonable rates for United States-flag commercial vessels.

(2) To furnish within 20 days following the date of loading for shipments originating within the United States or within 30 working days following the date of loading for shipments originating outside the United States a legible copy of a rated, 'on-board' commercial ocean bill-of-lading in English for each shipment of cargo described in paragraph (b) (1) of this section to both the Contracting Officer (through the prime contractor in the case of subcontractor bills-of-lading) and to the Division of National Cargo, Office of Market Development, Maritime Administration, Washington, DC 20590.

(3) To insert the substance of the provisions of this clause in all subcontracts issued pursuant to this contract."

**SUBSURFACE INFORMATION:**

(7-1-95)

450

SP1 G112 A

There is **no** subsurface information available on this project. The Contractor shall make his own investigation of subsurface conditions.

**MAINTENANCE OF THE PROJECT:**

(11-20-07) (Rev. 1-17-12)

104-10

SP1 G125

Revise the *2018 Standard Specifications* as follows:

**Page 1-39, Article 104-10 Maintenance of the Project, line 25**, add the following after the first sentence of the first paragraph:

All guardrail/guiderail within the project limits shall be included in this maintenance.

**Page 1-39, Article 104-10 Maintenance of the Project, line 30**, add the following as the last sentence of the first paragraph:

The Contractor shall perform weekly inspections of guardrail and guiderail and shall report damages to the Engineer on the same day of the weekly inspection. *Where damaged guardrail or guiderail is repaired or replaced as a result of maintaining the project* in accordance with this article, such repair or replacement shall be performed within 7 consecutive calendar days of such inspection report.

**Page 1-39, Article 104-10 Maintenance of the Project, lines 42-44**, replace the last sentence of the last paragraph with the following:

The Contractor will not be directly compensated for any maintenance operations necessary, except for maintenance of guardrail/guiderail, as this work will be considered incidental to the work covered by the various contract items. The provisions of Article 104-7, Extra Work, and Article 104-8, Compensation and Record Keeping will apply to authorized maintenance of guardrail/guiderail. Performance of weekly inspections of guardrail/guiderail, and the damage reports required as described above, will be considered to be an incidental part of the work being paid for by the various contract items.

**TWELVE MONTH GUARANTEE:**

(7-15-03)

108

SP1 G145

- (A) The Contractor shall guarantee materials and workmanship against latent and patent defects arising from faulty materials, faulty workmanship or negligence for a period of twelve months following the date of final acceptance of the work for maintenance and shall replace such defective materials and workmanship without cost to the Department. The Contractor will not be responsible for damage due to faulty design, normal wear and tear, for negligence on the part of the Department, and/or for use in excess of the design.
- (B) Where items of equipment or material carry a manufacturer's guarantee for any period in excess of twelve months, then the manufacturer's guarantee shall apply for that particular piece of equipment or material. The Department's first remedy shall be through the manufacturer although the Contractor is responsible for invoking the warranted repair work with the manufacturer. The Contractor's responsibility shall be limited to the term of the manufacturer's guarantee. NCDOT would be afforded the same warranty as provided by the Manufacturer.

This guarantee provision shall be invoked only for major components of work in which the Contractor would be wholly responsible for under the terms of the contract. Examples would

include pavement structures, bridge components, and sign structures. This provision will not be used as a mechanism to force the Contractor to return to the project to make repairs or perform additional work that the Department would normally compensate the Contractor for. In addition, routine maintenance activities (i.e. mowing grass, debris removal, ruts in earth shoulders,) are not parts of this guarantee.

Appropriate provisions of the payment and/or performance bonds shall cover this guarantee for the project.

To ensure uniform application statewide the Division Engineer will forward details regarding the circumstances surrounding any proposed guarantee repairs to the Chief Engineer for review and approval prior to the work being performed.

### **EROSION AND SEDIMENT CONTROL/STORMWATER CERTIFICATION:**

(1-16-07) (Rev 11-22-16)

105-16, 225-2, 16

SP1 G180

#### **General**

Schedule and conduct construction activities in a manner that will minimize soil erosion and the resulting sedimentation and turbidity of surface waters. Comply with the requirements herein regardless of whether or not a National Pollution discharge Elimination System (NPDES) permit for the work is required.

Establish a chain of responsibility for operations and subcontractors' operations to ensure that the *Erosion and Sediment Control/Stormwater Pollution Prevention Plan* is implemented and maintained over the life of the contract.

- (A) *Certified Supervisor* - Provide a certified Erosion and Sediment Control/Stormwater Supervisor to manage the Contractor and subcontractor operations, insure compliance with Federal, State and Local ordinances and regulations, and manage the Quality Control Program.
- (B) *Certified Foreman* - Provide a certified, trained foreman for each construction operation that increases the potential for soil erosion or the possible sedimentation and turbidity of surface waters.
- (C) *Certified Installer* - Provide a certified installer to install or direct the installation for erosion or sediment/stormwater control practices.
- (D) *Certified Designer* - Provide a certified designer for the design of the erosion and sediment control/stormwater component of reclamation plans and, if applicable, for the design of the project erosion and sediment control/stormwater plan.

#### **Roles and Responsibilities**

- (A) *Certified Erosion and Sediment Control/Stormwater Supervisor* - The Certified Supervisor shall be Level II and responsible for ensuring the erosion and sediment control/stormwater plan is adequately implemented and maintained on the project and for conducting the quality control program. The Certified Supervisor shall be on the project within 24 hours



notice from initial exposure of an erodible surface to the project's final acceptance. Perform the following duties:

- (1) Manage Operations - Coordinate and schedule the work of subcontractors so that erosion and sediment control/stormwater measures are fully executed for each operation and in a timely manner over the duration of the contract.
  - (a) Oversee the work of subcontractors so that appropriate erosion and sediment control/stormwater preventive measures are conformed to at each stage of the work.
  - (b) Prepare the required National Pollutant Discharge Elimination System (NPDES) Inspection Record and submit to the Engineer.
  - (c) Attend all weekly or monthly construction meetings to discuss the findings of the NPDES inspection and other related issues.
  - (d) Implement the erosion and sediment control/stormwater site plans requested.
  - (e) Provide any needed erosion and sediment control/stormwater practices for the Contractor's temporary work not shown on the plans, such as, but not limited to work platforms, temporary construction, pumping operations, plant and storage yards, and cofferdams.
  - (f) Acquire applicable permits and comply with requirements for borrow pits, dewatering, and any temporary work conducted by the Contractor in jurisdictional areas.
  - (g) Conduct all erosion and sediment control/stormwater work in a timely and workmanlike manner.
  - (h) Fully perform and install erosion and sediment control/stormwater work prior to any suspension of the work.
  - (i) Coordinate with Department, Federal, State and Local Regulatory agencies on resolution of erosion and sediment control/stormwater issues due to the Contractor's operations.
  - (j) Ensure that proper cleanup occurs from vehicle tracking on paved surfaces or any location where sediment leaves the Right-of-Way.
  - (k) Have available a set of erosion and sediment control/stormwater plans that are initialed and include the installation date of Best Management Practices. These practices shall include temporary and permanent groundcover and be properly updated to reflect necessary plan and field changes for use and review by Department personnel as well as regulatory agencies.
  
- (2) Requirements set forth under the NPDES Permit - The Department's NPDES Stormwater permit (NCS000250) outlines certain objectives and management measures pertaining to construction activities. The permit references *NCG010000, General Permit to Discharge Stormwater* under the NPDES, and states that the Department shall incorporate the applicable requirements into its delegated Erosion and Sediment Control Program for construction activities disturbing one or more acres of land. The Department further incorporates these requirements on all contracted bridge and culvert work at jurisdictional waters, regardless of size. Some of the requirements are, but are not limited to:

- (a) Control project site waste to prevent contamination of surface or ground waters of the state, i.e. from equipment operation/maintenance, construction materials, concrete washout, chemicals, litter, fuels, lubricants, coolants, hydraulic fluids, any other petroleum products, and sanitary waste.
  - (b) Inspect erosion and sediment control/stormwater devices and stormwater discharge outfalls at least once every 7 calendar days and within 24 hours after a rainfall event of 0.5 inch that occurs within a 24 hour period. Additional monitoring may be required at the discretion of Division of Water Resources personnel if the receiving stream is 303(d) listed for turbidity and the project has had documented problems managing turbidity.
  - (c) Maintain an onsite rain gauge or use the Department's Multi-Sensor Precipitation Estimate website to maintain a daily record of rainfall amounts and dates.
  - (d) Maintain erosion and sediment control/stormwater inspection records for review by Department and Regulatory personnel upon request.
  - (e) Implement approved reclamation plans on all borrow pits, waste sites and staging areas.
  - (f) Maintain a log of turbidity test results as outlined in the Department's Procedure for Monitoring Borrow Pit Discharge.
  - (g) Provide secondary containment for bulk storage of liquid materials.
  - (h) Provide training for employees concerning general erosion and sediment control/stormwater awareness, the Department's NPDES Stormwater Permit NCS000250 requirements, and the applicable requirements of the *General Permit, NCG010000*.
  - (i) Report violations of the NPDES permit to the Engineer immediately who will notify the Division of Water Quality Regional Office within 24 hours of becoming aware of the violation.
- (3) Quality Control Program - Maintain a quality control program to control erosion, prevent sedimentation and follow provisions/conditions of permits. The quality control program shall:
- (a) Follow permit requirements related to the Contractor and subcontractors' construction activities.
  - (b) Ensure that all operators and subcontractors on site have the proper erosion and sediment control/stormwater certification.
  - (c) Notify the Engineer when the required certified erosion and sediment control/stormwater personnel are not available on the job site when needed.
  - (d) Conduct the inspections required by the NPDES permit.
  - (e) Take corrective actions in the proper timeframe as required by the NPDES permit for problem areas identified during the NPDES inspections.
  - (f) Incorporate erosion control into the work in a timely manner and stabilize disturbed areas with mulch/seed or vegetative cover on a section-by-section basis.
  - (g) Use flocculants approved by state regulatory authorities where appropriate and where required for turbidity and sedimentation reduction.
  - (h) Ensure proper installation and maintenance of temporary erosion and sediment control devices.

- (i) Remove temporary erosion or sediment control devices when they are no longer necessary as agreed upon by the Engineer.
  - (j) The Contractor's quality control and inspection procedures shall be subject to review by the Engineer. Maintain NPDES inspection records and make records available at all times for verification by the Engineer.
- (B) *Certified Foreman* - At least one Certified Foreman shall be onsite for each type of work listed herein during the respective construction activities to control erosion, prevent sedimentation and follow permit provisions:
- (1) Foreman in charge of grading activities
  - (2) Foreman in charge of bridge or culvert construction over jurisdictional areas
  - (3) Foreman in charge of utility activities

The Contractor may request to use the same person as the Level II Supervisor and Level II Foreman. This person shall be onsite whenever construction activities as described above are taking place. This request shall be approved by the Engineer prior to work beginning.

The Contractor may request to name a single Level II Foreman to oversee multiple construction activities on small bridge or culvert replacement projects. This request shall be approved by the Engineer prior to work beginning.

- (C) *Certified Installers* - Provide at least one onsite, Level I Certified Installer for each of the following erosion and sediment control/stormwater crew:
- (1) Seeding and Mulching
  - (2) Temporary Seeding
  - (3) Temporary Mulching
  - (4) Sodding
  - (5) Silt fence or other perimeter erosion/sediment control device installations
  - (6) Erosion control blanket installation
  - (7) Hydraulic tackifier installation
  - (8) Turbidity curtain installation
  - (9) Rock ditch check/sediment dam installation
  - (10) Ditch liner/matting installation
  - (11) Inlet protection
  - (12) Riprap placement
  - (13) Stormwater BMP installations (such as but not limited to level spreaders, retention/detention devices)
  - (14) Pipe installations within jurisdictional areas

If a Level I *Certified Installer* is not onsite, the Contractor may substitute a Level II Foreman for a Level I Installer, provided the Level II Foreman is not tasked to another crew requiring Level II Foreman oversight.

- (D) *Certified Designer* - Include the certification number of the Level III-B Certified Designer on the erosion and sediment control/stormwater component of all reclamation plans and if

applicable, the certification number of the Level III-A Certified Designer on the design of the project erosion and sediment control/stormwater plan.

### **Preconstruction Meeting**

Furnish the names of the *Certified Erosion and Sediment Control/Stormwater Supervisor*, *Certified Foremen*, *Certified Installers* and *Certified Designer* and notify the Engineer of changes in certified personnel over the life of the contract within 2 days of change.

### **Ethical Responsibility**

Any company performing work for the North Carolina Department of Transportation has the ethical responsibility to fully disclose any reprimand or dismissal of an employee resulting from improper testing or falsification of records.

### **Revocation or Suspension of Certification**

Upon recommendation of the Chief Engineer to the certification entity, certification for *Supervisor*, *Certified Foremen*, *Certified Installers* and *Certified Designer* may be revoked or suspended with the issuance of an *Immediate Corrective Action (ICA)*, *Notice of Violation (NOV)*, or *Cease and Desist Order* for erosion and sediment control/stormwater related issues.

The Chief Engineer may recommend suspension or permanent revocation of certification due to the following:

- (A) Failure to adequately perform the duties as defined within this certification provision.
- (B) Issuance of an ICA, NOV, or Cease and Desist Order.
- (C) Failure to fully perform environmental commitments as detailed within the permit conditions and specifications.
- (D) Demonstration of erroneous documentation or reporting techniques.
- (E) Cheating or copying another candidate's work on an examination.
- (F) Intentional falsification of records.
- (G) Directing a subordinate under direct or indirect supervision to perform any of the above actions.
- (H) Dismissal from a company for any of the above reasons.
- (I) Suspension or revocation of one's certification by another entity.

Suspension or revocation of a certification will be sent by certified mail to the certificant and the Corporate Head of the company that employs the certificant.

A certificant has the right to appeal any adverse action which results in suspension or permanent revocation of certification by responding, in writing, to the Chief Engineer within 10 calendar days after receiving notice of the proposed adverse action.

Chief Engineer  
1536 Mail Service Center  
Raleigh, NC 27699-1536

Failure to appeal within 10 calendar days will result in the proposed adverse action becoming effective on the date specified on the certified notice. Failure to appeal within the time specified will result in a waiver of all future appeal rights regarding the adverse action taken. The certificant will not be allowed to perform duties associated with the certification during the appeal process.

The Chief Engineer will hear the appeal and make a decision within 7 days of hearing the appeal. Decision of the Chief Engineer will be final and will be made in writing to the certificant.

If a certification is temporarily suspended, the certificant shall pass any applicable written examination and any proficiency examination, at the conclusion of the specified suspension period, prior to having the certification reinstated.

### **Measurement and Payment**

*Certified Erosion and Sediment Control/Stormwater Supervisor, Certified Foremen, Certified Installers and Certified Designer* will be incidental to the project for which no direct compensation will be made.

**PROJECT SPECIAL PROVISIONS****ROADWAY****BURNING RESTRICTIONS:**

(7-1-95)

200, 210, 215

SP2 R05

Open burning is not permitted on any portion of the right-of-way limits established for this project. Do not burn the clearing, grubbing or demolition debris designated for disposal and generated from the project at locations within the project limits, off the project limits or at any waste or borrow sites in this county. Dispose of the clearing, grubbing and demolition debris by means other than burning, according to state or local rules and regulations.

**VERY HIGH EARLY STRENGTH CONCRETE FOR CONCRETE PAVEMENT****REPAIR:**

(Revised 11-01-16)

SPI 7-10

Submit mix designs for Very High Early Strength Concrete for Concrete Pavement Repair in terms of saturated surface dry weights on M & T Form 312U for acceptance at least 30 days before proposed use.

Use a mix sufficient to obtain at least a flexural strength of 400 psi at 4 hours. Entrain 5 %  $\pm$  1.5% air in the freshly mixed concrete. Produce the mix with a maximum slump of 1.5" for placement by a fully mechanized paving train and a maximum slump of 3" for hand placement.

Use cement, fine aggregate, coarse aggregate, admixtures and, optionally, pozzolan as shown on the Department's approved list.

Submit 4 hour flexural strength results of at least 6 beams made and tested in accordance with AASHTO T126 and T97 with M & T Form 312U. In addition, submit 4 hour compressive strength results of at least six 4" by 8" or 6" by 12" cylinders and maturity test results of the mix. With permission of the Engineer, compressive strength testing and maturity testing may be used in lieu of or concurrent with flexural strength testing to determine the acceptability of the concrete in the field.

Design and produce the mix in accordance with a concrete system that can produce 400 psi flexural strength in approximately 4 hours or a comparable equal system. The timing of the addition of hydration control admixtures is critical to the performance of this concrete; therefore, an admixture representative shall be present on the job when Very High Early Strength Concrete is batched.

**DIAMOND GRINDING CONCRETE PAVEMENT:**

(4-15-08) (Rev 08-16-16)

SPI 7-9 (REV.)

**Description**

Perform the work covered by this provision including but not limited to diamond grinding and regrinding concrete pavement to meet final surface acceptable smoothness requirements detailed in Article 710-7, selecting diamond tipped saw blades and configuration of cutting head; continual removal of residual slurry from pavement and disposal; furnishing all labor, materials, supplies, tools, equipment and incidentals as necessary. Perform this work at locations indicated in the plans

or as directed by the Engineer.

Prior to beginning any diamond grinding operations, schedule a pre-grind meeting with grinding subcontractor, Division Construction Engineer, Project Engineer, Area Roadway Engineer, State Pavement Construction Engineer, representatives from the Roadside Environmental Unit and the Materials and Tests Unit.

### **Equipment**

Use equipment with diamond tipped saw blades gang mounted on a power driven self-propelled machine with a minimum wheel base length of 15 feet that is specifically designed to smooth and texture Portland Cement Concrete pavement. Utilize equipment that does not cause ravels; aggregate fracture; spalls or disturbance to the longitudinal or transverse joints; or damage and/or strain to the underlying surface of the pavement. Should any of the above problems occur immediately suspend operations.

Provide a minimum 3 feet wide grinding head with 50 to 60 evenly spaced grooves per foot. Prior to designing the grinding head, evaluate the aggregate hardness of the concrete pavement and select the appropriate diamond size, diamond concentration and bond hardness for the individual saw blades.

Provide vacuuming equipment to continuously remove slurry residue and excess water from the pavement as part of the grinding operation. Do not allow the slurry material to flow into a travel lane occupied by traffic or into any drainage facility.

### **Method of Construction**

Grind the pavement surface to a uniform appearance with a high skid resistant longitudinal corduroy type texture. Provide grooves between 0.09 and 0.15 inches wide with the land area between the grooves between 0.06 and 0.13 inches wide. Ensure a ridge peak of approximately 0.0625 inches higher than the bottom of the grooves.

Begin and end diamond grinding at lines normal to the pavement centerline. Grind only in the longitudinal direction. All grooves and adjacent passes shall be parallel to each other with no variation. Completely lap adjacent passes with no unground surface remaining between passes and no overlap of more than 1½ inches. Adjacent passes shall be within 1/8 inch of the same height as measured with a 3 foot straightedge. Maintain positive cross-slope drainage for the duration of the grinding operation.

Grind all travel lanes to include auxiliary lanes, ramps and loops with not less than 98 percent of the specified surface being textured by grinding. Grinding of the bridge decks and concrete shoulders will not be required. Remove a minimum 0.0625 inches at all locations except dips. Extra grinding to eliminate minor depressions is not required. It is anticipated that extra grinding will be required on the high side of existing faults in the pavement. There shall be no ridge between lanes. In a separate operation, transition the grinding of any remaining ridges greater than 1/8 inch in height on the outside edge next to the shoulder or at a tie to an existing facility to the satisfaction of the Engineer.

**NCDOT has provided Mean Roughness Index (MRI) information for the existing roadway condition. This information can be found at the end of this provision. NCDOT will take final measurements after the completion of the Diamond Grinding process. Measurements will be taken in accordance with Section 710-7 of the 2018 Standard Specifications. Price adjustments will apply to each 0.10 mile section in accordance with Section 710-7.**

### **Disposal of Residual Slurry**

Diamond grinding slurry disposal shall be in accordance with the Statewide Permit for Land Application of Diamond Grinding Slurry (DGS), Permit No. WQ0035749 dated June 3, 2014. Submit a slurry disposal plan to the Engineer detailing method of handling and disposing of slurry from the diamond grinding operation a minimum of 60 days prior to beginning the diamond grinding operation. Engineer shall review the slurry disposal plan. Plan must be accepted prior to beginning the diamond grinding operation.

Disposal options are:

- (A) Land apply slurry directly from diamond grinding machine within the DOT right-of-way in the median, shoulders and slopes.
- (B) Collect, contain, haul, and land apply slurry within DOT right-of-way as directed by the Engineer and a representative from the Roadside Environmental Unit. Contractor shall disperse slurry through an operation that spreads slurry within allowable agronomic rates in an interchange or designated area.

If the above options for disposal of slurry do not qualify as acceptable methods as determined by the Department, then the Contractor will be compensated under Article 104-7 for any other disposal methods required by the Department.

To prevent the migration of any direct discharge from the diamond grinding machine or land applied DGS from entering a drainage inlet or structure, the contractor shall install wattles and silt fence at the direction of the Engineer. Silt Fence shall be installed in accordance with Section 1605 of the NCDOT 2018 *Standard Specifications*.

For more detailed information, see the Environmental Permits and Guidelines section under Environmental resources on the NC Connect website for the DG permit and guidelines at the following link. (NCID access required.)

<https://connect.ncdot.gov/resources/Environmental/Environmental%20Permits%20and%20Guidelines/Forms/AllItems.aspx>

### **Measurement and Payment**

The quantity of *Diamond Grinding PCC Pavement* to be paid for will be the actual number of square yards of pavement which has been satisfactorily diamond ground, measured along the final top surface of the pavement. No separate payment will be made for any overlapping, regrinding, or for extra grinding on the high side of existing faults.



Payment will be full compensation for the work, including but is not limited to grinding, disposal of slurry, final surface testing, furnishing all materials, equipment, labor and all incidentals necessary to satisfactorily complete the work.

*Temporary Silt Fence* will be measured and paid in linear feet, accepted in place, along the ground line of the fence.

*Wattle* will be measured and paid for by the actual number of linear feet of wattles which are installed and accepted. Such price and payment will be full compensation for all work covered by this section, including, but not limited to, furnishing all materials, labor, equipment and incidentals necessary to install the *Wattle*.

Payment will be made under:

**Pay Item**

Diamond Grinding PCC Pavement  
Temporary Silt Fence  
Wattle

**Pay Unit**

Square Yard  
Linear Foot  
Linear Foot

**EXISTING MEAN ROUGHNESS INDEX**

(Data Collected October 13, 2017)

<i>From</i>	<i>To</i>	<i>South1</i>	<i>South2</i>	<i>South3</i>	<i>South4</i>	<i>North1</i>	<i>North2</i>	<i>North3</i>	<i>North4</i>
0.0	0.1	126	128	112	103	123	166	121	135
0.1	0.2	228	200	165	166	108	137	97	100
0.2	0.3	133	120	130	141	131	138	120	131
0.3	0.4	150	136	110	107	119	121	122	118
0.4	0.5	159	138	96	120	114	116	124	130
0.5	0.6	133	144	105	98	118	100	147	176
0.6	0.7	216	164	109	151	119	133	168	217
0.7	0.8	162	174	90	99	114	161	164	179
0.8	0.9	158	174	99	111	133	165	166	181
0.9	1.0	177	190	123	110	151	136	153	162
1.0	1.1	154	165	98	101	136	126	164	192
1.1	1.2	155	178	104	101	150	129	126	143
1.2	1.3	122	148	99	112	190	139	154	151
1.3	1.4	148	183	86	100	149	130	157	148
1.4	1.5	164	180	97	123	117	136	180	167
1.5	1.6	127	126	97	127	162	103	158	164
1.6	1.7	93	120	118	138	138	102	112	110
1.7	1.8	105	134	125	127	111	81	84	79
1.8	1.9	113	128	123	132	161	119	129	136
1.9	2.0	113	107	109	121	191	191	182	196
2.0	2.1	107	92	115	114	179	203	184	210
2.1	2.2	118	106	97	102	144	123	118	169
2.2	2.3	136	113	85	96	92	96	80	87
2.3	2.4	142	149	109	101	145	139	138	211
2.4	2.5	123	152	138	121	125	117	121	184
2.5	2.6	103	140	105	144	142	187	149	214
2.6	2.7	102	114	98	117	134	107	125	135
2.7	2.8	97	123	131	137	124	91	92	98
2.8	2.9	123	141	96	88	95	92	111	111
2.9	3.0	132	137	100	110	98	94	118	119
3.0	3.1	95	130	106	107	120	129	142	131
3.1	3.2	123	144	100	90	144	112	98	88
3.2	3.3	112	153	99	94	153	123	107	93
3.3	3.4	119	144	116	98	148	123	119	102
3.4	3.5	105	150	97	102	170	126	106	107
3.5	3.6	180	161	118	108	168	190	119	95
3.6	3.7	133	140	141	122	87	87	152	119
3.7	3.8	156	168	160	158	170	145	156	164
3.8	3.9	200	177	192	154	114	108	147	124

3.9	4.0	151	159	128	136	128	132	129	105
4.0	4.1	149	133	145	162	123	155	128	107
4.1	4.2	116	121	109	107	117	136	89	90
4.2	4.3	138	119	99	111	118	139	120	116
4.3	4.4	143	105	100	108	105	118	103	77
4.4	4.5	104	110	96	111	111	134	127	114
4.5	4.6	108	120	150	135	121	119	104	100
4.6	4.7	105	118	148	121	119	123	126	104
4.7	4.8	109	120	138	117	126	106	99	84
4.8	4.9	116	108	133	120	97	139	142	123
4.9	5.0	138	204	172	174	114	140	154	116
5.0	5.1	153	118	152	156	135	147	119	92
5.1	5.2	116	108	138	157	120	147	130	99
5.2	5.3	118	145	153	89	125	119	94	94
5.3	5.4	105	104	123	79	122	118	103	94
5.4	5.5	111	112	141	165	108	129	101	108
5.5	5.6	225	217	220	196	115	129	116	110
5.6	5.7	164	174	196	211	115	136	135	120
5.7	5.8	154	110	125	145	134	119	119	104
5.8	5.9	178	133	135	113	118	126	123	113
5.9	6.0	124	140	64	104	108	121	124	105
6.0	6.1	177	159	116	96	113	112	139	106
6.1	6.2	111	146	112	98	173	156	125	102
6.2	6.3	142	168	94	86	192	191	90	91
6.3	6.4	131	139	112	103	220	235	104	97
6.4	6.5	139	140	144	122	180	245	98	95
6.5	6.6	141	131	132	122	207	190	101	101
6.6	6.7	152	144	181	110	177	197	96	97
6.7	6.8	142	150	175	109	135	148	88	99
6.8	6.9	92	137	155	102	140	173	83	99
6.9	7.0	112	113	132	90	173	151	93	98
7.0	7.1	106	105	125	102	135	131	108	106
7.1	7.2	128	131	121	125	117	147	100	95
7.2	7.3	105	135	124	141	216	156	127	132
7.3	7.4	174	132	113	150	137	152	124	121
7.4	7.5	186	119	99	105	207	185	144	114
7.5	7.6	198	187	138	157	138	158	109	118
<b>Average*</b>		<b>133</b>	<b>137</b>	<b>118</b>	<b>117</b>	<b>134</b>	<b>135</b>	<b>121</b>	<b>120</b>



*South Bound MRI Data Collection Starting Location and Lane Number Designation*

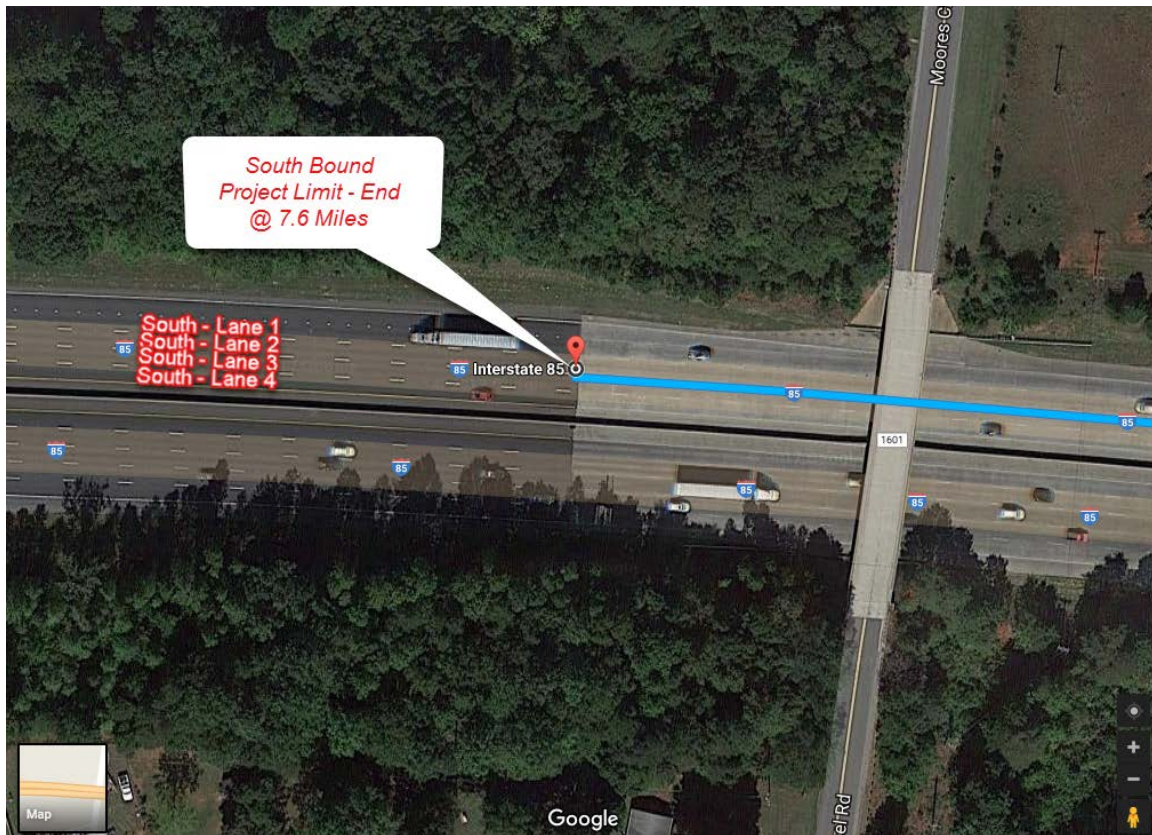

*South Bound MRI Data Collection Ending Location and Lane Number Designation*



*North Bound MRI Data Collection Starting Location and Lane Number Designation*



*North Bound MRI Data Collection Ending Location and Lane Number Designation*

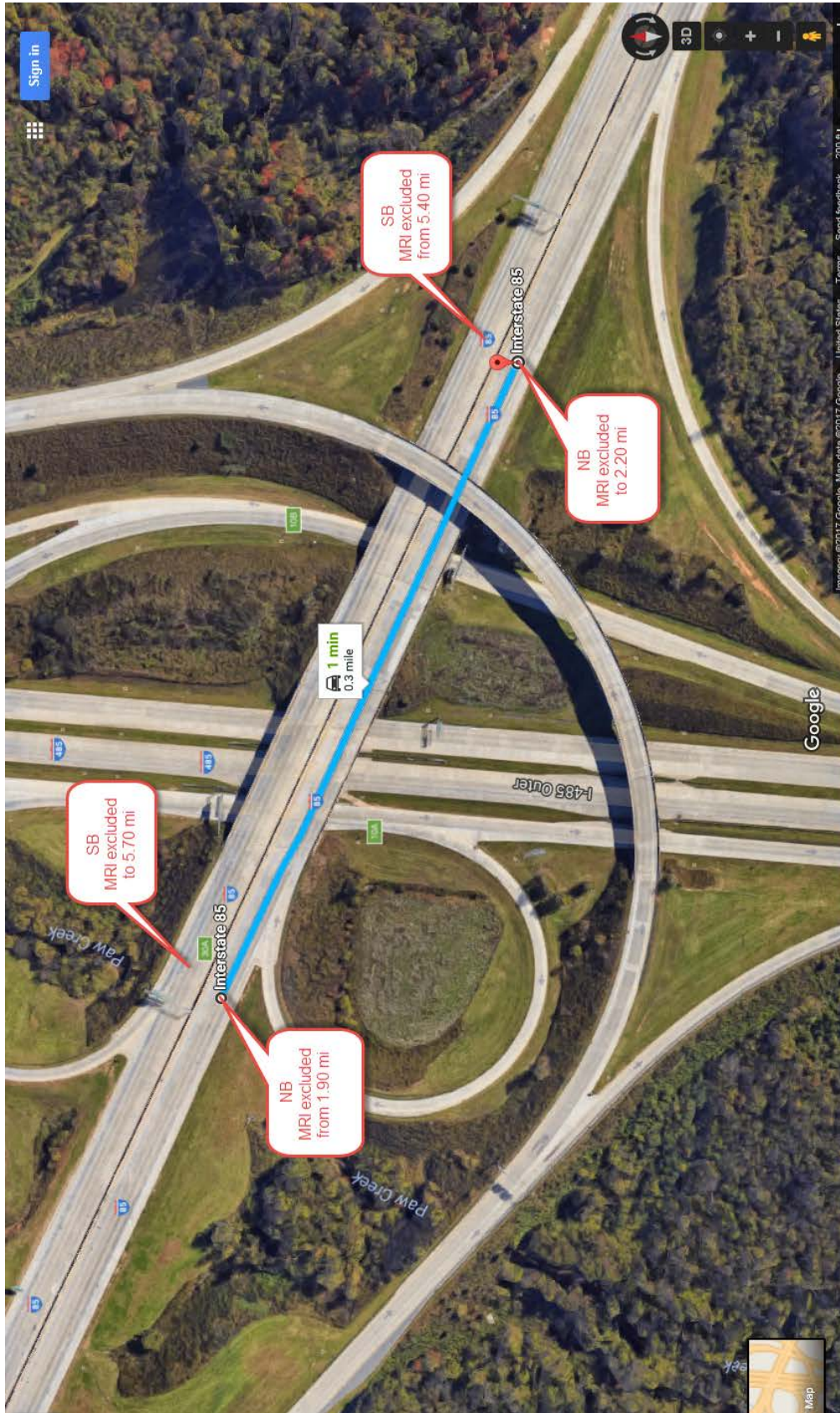

North Bound and South Bound 0.3 Mile Segment Excluded from Overall MRI Average due to Bridge Deck(s)



*North Bound and South Bound 0.2 Mile Segment Excluded from Overall MRI Average due to Bridge Deck(s)*

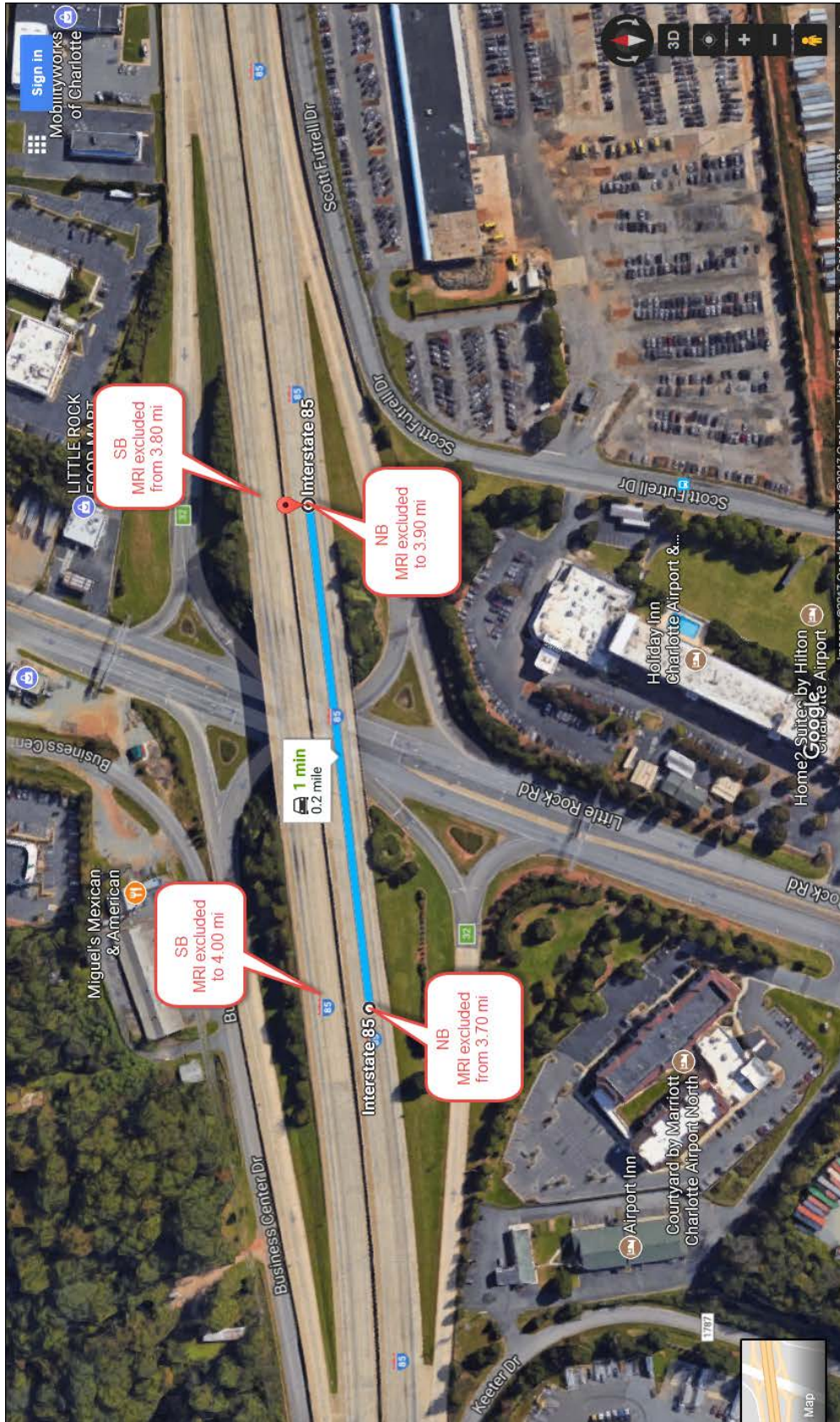

*North Bound and South Bound 0.2 Mile Segment Excluded from Overall MRI Average due to Bridge Deck(s)*





*North Bound and South Bound 0.1 Mile Segment Excluded from Overall MRI Average due to Bridge Deck(s)*

**COLD APPLIED PLASTIC PAVEMENT MARKING LINES, TYPE II (9'')**

(5-1-16)

Div 10

**Description**

The Contractor shall install Cold Applied Plastic Pavement Marking Lines, Type II (9'') in accordance with the applicable requirements of Section 1205 of the *2018 Standard Specifications*, and as directed by the Engineer. This line shall be a 10' skip with a contrast White/Black line. The white line shall be a 6'' wide with a 1.5'' black border on each side. Any alteration to this design must be approved by the Engineer prior to installation.

**Materials**

Refer to Article 1205-6 of the *2018 Standard Specifications*.

**Measurement and Payment**

*Cold Applied Plastic Pavement Marking Lines, Type II (9'')* will be measured and paid for as the actual number of linear feet of pavement marking lines satisfactorily placed and accepted by the Engineer. Such price and payment will include all materials, tools, labor, equipment and incidentals necessary to satisfactorily complete the work.

Payment will be made under:

<b>Pay Item</b>	<b>Pay Unit</b>
Cold Applied Plastic Pavement Marking Lines, Type II (9'')	Linear Foot

**REMOVE AND REPLACE SNOWPLOWABLE PAVEMENT MARKERS :**

(02/06/2013) rev.4-26-17

**Description**

The Contractor shall remove and replace snowplowable pavement markers in accordance with the applicable requirements of Section 1253 of the *2018 Standard Specifications*, this Provision and as directed by the Engineer.

**Construction**

Remove the existing Snowplowable Pavement Markers as directed by the Engineer.

Install new Snowplowable Pavement Marker Castings. The slot for the castings shall be properly prepared by the method recommended by the manufacturer of the marker prior to installing the new casting.

The Contractor shall complete this operation by using adhesives and methods recommended by the manufacturer of the markers and approved by the Engineer.

Any slots remaining from the removal of the existing markers shall be patched using a NCDOT approved product for patching concrete pavement.

**Measurement and Payment**

*Remove and Replace Snowplowable Pavement Markers* will be measured and paid as the actual number of snowplowable pavement markers satisfactorily removed, replaced and accepted.

Payment will be made under:

<b>Pay Item</b>	<b>Pay Unit</b>
Remove and Replace Snowplowable Pavement Markers	Each

**STANDARD SPECIAL PROVISION**  
**AVAILABILITY OF FUNDS – TERMINATION OF CONTRACTS**

(5-20-08)

Z-2

*General Statute 143C-6-11. (h) Highway Appropriation* is hereby incorporated verbatim in this contract as follows:

(h) Amounts Encumbered. – Transportation project appropriations may be encumbered in the amount of allotments made to the Department of Transportation by the Director for the estimated payments for transportation project contract work to be performed in the appropriation fiscal year. The allotments shall be multiyear allotments and shall be based on estimated revenues and shall be subject to the maximum contract authority contained in *General Statute 143C-6-11(c)*. Payment for transportation project work performed pursuant to contract in any fiscal year other than the current fiscal year is subject to appropriations by the General Assembly. Transportation project contracts shall contain a schedule of estimated completion progress, and any acceleration of this progress shall be subject to the approval of the Department of Transportation provided funds are available. The State reserves the right to terminate or suspend any transportation project contract, and any transportation project contract shall be so terminated or suspended if funds will not be available for payment of the work to be performed during that fiscal year pursuant to the contract. In the event of termination of any contract, the contractor shall be given a written notice of termination at least 60 days before completion of scheduled work for which funds are available. In the event of termination, the contractor shall be paid for the work already performed in accordance with the contract specifications.

Payment will be made on any contract terminated pursuant to the special provision in accordance with Subarticle 108-13(D) of the *2018 Standard Specifications*.

**STANDARD SPECIAL PROVISION**

**ERRATA**

(2-12-18)

Z-4

Revise the *2018 Standard Specifications* as follows:

**Division 7**

**Page 7-27, line 4, Article 725-1 MEASUREMENT AND PAYMENT**, replace article number “725-1” with “724-4”.

**Page 7-28, line 10, Article 725-1 MEASUREMENT AND PAYMENT**, replace article number “725-1” with “725-3”.

**Division 10**

**Page 10-162, line 1, Article 1080-50 PAINT FOR VERTICAL MARKERS**, replace article number “1080-50” with “1080-10”.

**Page 10-162, line 5, Article 1080-61 EPOXY RESIN FOR REINFORCING STEEL**, replace article number “1080-61” with “1080-11”.

**Page 10-162, line 22, Article 1080-72 ABRASIVE MATERIALS FOR BLAST CLEANING STEEL**, replace article number “1080-72” with “1080-12”.

**Page 10-163, line 25, Article 1080-83 FIELD PERFORMANCE AND SERVICES**, replace article number “1080-83” with “1080-13”.

**STANDARD SPECIAL PROVISION****PLANT AND PEST QUARANTINES****(Imported Fire Ant, Gypsy Moth, Witchweed, Emerald Ash Borer, And Other Noxious Weeds)**

(3-18-03) (Rev. 12-20-16)

Z-04a

**Within Quarantined Area**

This project may be within a county regulated for plant and/or pests. If the project or any part of the Contractor's operations is located within a quarantined area, thoroughly clean all equipment prior to moving out of the quarantined area. Comply with federal/state regulations by obtaining a certificate or limited permit for any regulated article moving from the quarantined area.

**Originating in a Quarantined County**

Obtain a certificate or limited permit issued by the N.C. Department of Agriculture/United States Department of Agriculture. Have the certificate or limited permit accompany the article when it arrives at the project site.

**Contact**

Contact the N.C. Department of Agriculture/United States Department of Agriculture at 1-800-206-9333, 919-707-3730, or <http://www.ncagr.gov/plantindustry/> to determine those specific project sites located in the quarantined area or for any regulated article used on this project originating in a quarantined county.

**Regulated Articles Include**

1. Soil, sand, gravel, compost, peat, humus, muck, and decomposed manure, separately or with other articles. This includes movement of articles listed above that may be associated with cut/waste, ditch pulling, and shoulder cutting.
2. Plants with roots including grass sod.
3. Plant crowns and roots.
4. Bulbs, corms, rhizomes, and tubers of ornamental plants.
5. Hay, straw, fodder, and plant litter of any kind.
6. Clearing and grubbing debris.
7. Used agricultural cultivating and harvesting equipment.
8. Used earth-moving equipment.
9. Any other products, articles, or means of conveyance, of any character, if determined by an inspector to present a hazard of spreading imported fire ant, gypsy moth, witchweed, emerald ash borer, or other noxious weeds.

**STANDARD SPECIAL PROVISION****MINORITY AND FEMALE EMPLOYMENT REQUIREMENTS**

Z-7

**NOTICE OF REQUIREMENTS FOR AFFIRMATIVE ACTION TO ENSURE EQUAL EMPLOYMENT OPPORTUNITY (*EXECUTIVE NUMBER 11246*)**

1. The goals and timetables for minority and female participation, expressed in percentage terms for the Contractor's aggregate workforce in each trade on all construction work in the covered area, see as shown on the attached sheet entitled "Employment Goals for Minority and Female participation".

These goals are applicable to all the Contractor's construction work (whether or not it is Federal or federally assisted) performed in the covered area. If the Contractor performs construction work in a geographical area located outside of the covered area, it shall apply the goals established for such geographical area where the work is actually performed. With regard to this second area, the Contractor also is subject to the goals for both its federally involved and nonfederally involved construction.

The Contractor's compliance with the Executive Order and the regulations in *41 CFR Part 60-4* shall be based on its implementation of the Equal Opportunity Clause, specific affirmative action obligations required by the specifications set forth in *41 CFR 60-4.3(a)*, and its effort to meet the goals. The hours of minority and female employment and training must be substantially uniform throughout the length of the contract, and in each trade and the Contractor shall make a good faith effort to employ minorities and women evenly on each of its projects. The transfer of minority or female employees or trainees from Contractor to Contractor or from project to project for the sole purpose of meeting the Contractor's goals shall be a violation of the contract, the executive Order and the regulations in *41 CFR Part 60-4*. Compliance with the goals will be measured against the total work hours performed.

2. As used in this Notice and in the contract resulting from this solicitation, the "covered area" is the county or counties shown on the cover sheet of the proposal form and contract.

**EMPLOYMENT GOALS FOR MINORITY  
AND FEMALE PARTICIPATION**

Economic Areas

**Area 023 29.7%**

Bertie County  
Camden County  
Chowan County  
Gates County  
Hertford County  
Pasquotank County  
Perquimans County

**Area 024 31.7%**

Beaufort County  
Carteret County  
Craven County  
Dare County  
Edgecombe County  
Green County  
Halifax County  
Hyde County  
Jones County  
Lenoir County  
Martin County  
Nash County  
Northampton County  
Pamlico County  
Pitt County  
Tyrrell County  
Washington County  
Wayne County  
Wilson County

**Area 025 23.5%**

Columbus County  
Duplin County  
Onslow County  
Pender County

**Area 026 33.5%**

Bladen County  
Hoke County  
Richmond County  
Robeson County  
Sampson County  
Scotland County

**Area 027 24.7%**

Chatham County  
Franklin County  
Granville County  
Harnett County  
Johnston County  
Lee County  
Person County  
Vance County  
Warren County

**Area 028 15.5%**

Alleghany County  
Ashe County  
Caswell County  
Davie County  
Montgomery County  
Moore County  
Rockingham County  
Surry County  
Watauga County  
Wilkes County

**Area 029 15.7%**

Alexander County  
Anson County  
Burke County  
Cabarrus County  
Caldwell County  
Catawba County  
Cleveland County  
Iredell County  
Lincoln County  
Polk County  
Rowan County  
Rutherford County  
Stanly County

**Area 0480 8.5%**

Buncombe County  
Madison County

**Area 030 6.3%**

Avery County  
Cherokee County  
Clay County  
Graham County  
Haywood County  
Henderson County  
Jackson County  
McDowell County  
Macon County  
Mitchell County  
Swain County  
Transylvania County  
Yancey County



**SMSA Areas**

**Area 5720 26.6%**  
Currituck County

**Area 9200 20.7%**  
Brunswick County  
New Hanover County

**Area 2560 24.2%**  
Cumberland County

**Area 6640 22.8%**  
Durham County  
Orange County  
Wake County

**Area 1300 16.2%**  
Alamance County

**Area 3120 16.4%**  
Davidson County  
Forsyth County  
Guilford County  
Randolph County  
Stokes County  
Yadkin County

**Area 1520 18.3%**  
Gaston County  
Mecklenburg County  
Union County

---

**Goals for Female**

**Participation in Each Trade**

(Statewide) 6.9%

**STANDARD SPECIAL PROVISION****REQUIRED CONTRACT PROVISIONS FEDERAL - AID CONSTRUCTION CONTRACTS**

FHWA - 1273 Electronic Version - May 1, 2012

Z-8

- I. General
- II. Nondiscrimination
- III. Nonsegregated Facilities
- IV. Davis-Bacon and Related Act Provisions
- V. Contract Work Hours and Safety Standards Act Provisions
- VI. Subletting or Assigning the Contract
- VII. Safety: Accident Prevention
- VIII. False Statements Concerning Highway Projects
- IX. Implementation of Clean Air Act and Federal Water Pollution Control Act
- X. Compliance with Governmentwide Suspension and Debarment Requirements
- XI. Certification Regarding Use of Contract Funds for Lobbying

**ATTACHMENTS**

- A. Employment and Materials Preference for Appalachian Development Highway System or Appalachian Local Access Road Contracts (included in Appalachian contracts only)

**I. GENERAL**

1. Form FHWA-1273 must be physically incorporated in each construction contract funded under Title 23 (excluding emergency contracts solely intended for debris removal). The contractor (or subcontractor) must insert this form in each subcontract and further require its inclusion in all lower tier subcontracts (excluding purchase orders, rental agreements and other agreements for supplies or services).
 

The applicable requirements of Form FHWA-1273 are incorporated by reference for work done under any purchase order, rental agreement or agreement for other services. The prime contractor shall be responsible for compliance by any subcontractor, lower-tier subcontractor or service provider.

Form FHWA-1273 must be included in all Federal-aid design-build contracts, in all subcontracts and in lower tier subcontracts (excluding subcontracts for design services, purchase orders, rental agreements and other agreements for supplies or services). The design-builder shall be responsible for compliance by any subcontractor, lower-tier subcontractor or service provider.

Contracting agencies may reference Form FHWA-1273 in bid proposal or request for proposal documents, however, the Form FHWA-1273 must be physically incorporated (not referenced) in all contracts, subcontracts and lower-tier subcontracts (excluding purchase orders, rental agreements and other agreements for supplies or services related to a construction contract).
2. Subject to the applicability criteria noted in the following sections, these contract provisions shall apply to all work performed on the contract by the contractor's own organization and with the assistance of workers under the contractor's immediate superintendence and to all work performed on the contract by piecework, station work, or by subcontract.
3. A breach of any of the stipulations contained in these Required Contract Provisions may be sufficient grounds for withholding of progress payments, withholding of final payment, termination of the contract, suspension / debarment or any other action determined to be appropriate by the contracting agency and FHWA.
4. Selection of Labor: During the performance of this contract, the contractor shall not use convict labor for any purpose within the limits of a construction project on a Federal-aid highway unless it is labor performed by convicts who are on parole, supervised release, or probation. The term Federal-aid highway does not include roadways functionally classified as local roads or rural minor collectors.

**II. NONDISCRIMINATION**

The provisions of this section related to 23 CFR Part 230 are applicable to all Federal-aid construction contracts and to all related construction subcontracts of \$10,000 or more. The provisions of 23 CFR Part 230 are not applicable to material supply, engineering, or architectural service contracts.

In addition, the contractor and all subcontractors must comply with the following policies: Executive Order 11246, 41 CFR 60, 29 CFR 1625-1627, Title 23 USC Section 140, the Rehabilitation Act of 1973, as amended (29 USC 794), Title VI of the Civil Rights Act of 1964, as amended, and related regulations including 49 CFR Parts 21, 26 and 27; and 23 CFR Parts 200, 230, and 633.

The contractor and all subcontractors must comply with: the requirements of the Equal Opportunity Clause in 41 CFR 60-1.4(b) and, for all construction contracts exceeding \$10,000, the Standard Federal Equal Employment Opportunity Construction Contract Specifications in 41 CFR 60-4.3.

Note: The U.S. Department of Labor has exclusive authority to determine compliance with Executive Order 11246 and the policies of the Secretary of Labor including 41 CFR 60, and 29 CFR 1625-1627. The contracting agency and the FHWA have the authority and the responsibility to ensure compliance with Title 23 USC Section 140, the Rehabilitation Act of 1973, as amended (29 USC 794), and Title VI of the Civil Rights Act of 1964, as amended, and related regulations including 49 CFR Parts 21, 26 and 27; and 23 CFR Parts 200, 230, and 633.

The following provision is adopted from 23 CFR 230, Appendix A, with appropriate revisions to conform to the U.S. Department of Labor (US DOL) and FHWA requirements.

1. **Equal Employment Opportunity:** Equal employment opportunity (EEO) requirements not to discriminate and to take affirmative action to assure equal opportunity as set forth under laws, executive orders, rules, regulations (28 CFR 35, 29 CFR 1630, 29 CFR 1625-1627, 41 CFR 60 and 49 CFR 27) and orders of the Secretary of Labor as modified by the provisions prescribed herein, and imposed pursuant to 23 U.S.C. 140 shall constitute the EEO and specific affirmative action standards for the contractor's project activities under this contract. The provisions of the Americans with Disabilities Act of 1990 (42 U.S.C. 12101 et seq.) set forth under 28 CFR 35 and 29 CFR 1630 are incorporated by reference in this contract. In the execution of this contract, the contractor agrees to comply with the following minimum specific requirement activities of EEO:
  - a. The contractor will work with the contracting agency and the Federal Government to ensure that it has made every good faith effort to provide equal opportunity with respect to all of its terms and conditions of employment and in their review of activities under the contract.
  - b. The contractor will accept as its operating policy the following statement:

"It is the policy of this Company to assure that applicants are employed, and that employees are treated during employment, without regard to their race, religion, sex, color, national origin, age or disability. Such action shall include: employment, upgrading, demotion, or transfer; recruitment or recruitment advertising; layoff or termination; rates of pay or other forms of compensation; and selection for training, including apprenticeship, pre-apprenticeship, and/or on-the-job training."

2. **EEO Officer:** The contractor will designate and make known to the contracting officers an EEO Officer who will have the responsibility for and must be capable of effectively administering and promoting an active EEO program and who must be assigned adequate authority and responsibility to do so.
3. **Dissemination of Policy:** All members of the contractor's staff who are authorized to hire, supervise, promote, and discharge employees, or who recommend such action, or who are substantially involved in such action, will be made fully cognizant of, and will implement, the contractor's EEO policy and contractual responsibilities to provide EEO in each grade and classification of employment. To ensure that the above agreement will be met, the following actions will be taken as a minimum:
  - a. Periodic meetings of supervisory and personnel office employees will be conducted before the start of work and then not less often than once every six months, at which time the contractor's EEO policy and its implementation will be reviewed and explained. The meetings will be conducted by the EEO Officer.
  - b. All new supervisory or personnel office employees will be given a thorough indoctrination by the EEO Officer, covering all major aspects of the contractor's EEO obligations within thirty days following their reporting for duty with the contractor.
  - c. All personnel who are engaged in direct recruitment for the project will be instructed by the EEO Officer in the contractor's procedures for locating and hiring minorities and women.
  - d. Notices and posters setting forth the contractor's EEO policy will be placed in areas readily accessible to employees, applicants for employment and potential employees.
  - e. The contractor's EEO policy and the procedures to implement such policy will be brought to the attention of employees by means of meetings, employee handbooks, or other appropriate means.
4. **Recruitment:** When advertising for employees, the contractor will include in all advertisements for employees the notation: "An Equal Opportunity Employer." All such advertisements will be placed in publications having a large circulation among minorities and women in the area from which the project work force would normally be derived.
  - a. The contractor will, unless precluded by a valid bargaining agreement, conduct systematic and direct recruitment through public and private employee referral sources likely to yield qualified minorities and women. To meet this requirement, the contractor will identify sources of potential minority group employees, and establish with such identified sources procedures whereby minority and women applicants may be referred to the contractor for employment consideration.
  - b. In the event the contractor has a valid bargaining agreement providing for exclusive hiring hall referrals, the contractor is expected to observe the provisions of that agreement to the extent that the system meets the contractor's compliance with EEO contract provisions. Where implementation of such an agreement has the effect of discriminating against minorities or women, or obligates the contractor to do the same, such implementation violates Federal nondiscrimination provisions.
  - c. The contractor will encourage its present employees to refer minorities and women as applicants for employment. Information and procedures with regard to referring such applicants will be discussed with employees.
5. **Personnel Actions:** Wages, working conditions, and employee benefits shall be established and administered, and personnel actions of every type, including hiring, upgrading, promotion, transfer, demotion, layoff, and termination, shall be taken without regard to race, color, religion, sex, national origin, age or disability. The following procedures shall be followed:
  - a. The contractor will conduct periodic inspections of project sites to insure that working conditions and employee facilities do not indicate discriminatory treatment of project site personnel.
  - b. The contractor will periodically evaluate the spread of wages paid within each classification to determine any evidence of discriminatory wage practices.
  - c. The contractor will periodically review selected personnel actions in depth to determine whether there is evidence of discrimination. Where evidence is found, the contractor will promptly take corrective action. If the review indicates that the discrimination may extend beyond the actions reviewed, such corrective action shall include all affected persons.
  - d. The contractor will promptly investigate all complaints of alleged discrimination made to the contractor in connection with its obligations under this contract, will attempt to resolve such complaints, and will take appropriate corrective action within a reasonable time. If the investigation indicates that the discrimination may affect persons other than the complainant, such corrective action shall include such other persons. Upon completion of each investigation, the contractor will inform every complainant of all of their avenues of appeal.
6. **Training and Promotion:**
  - a. The contractor will assist in locating, qualifying, and increasing the skills of minorities and women who are applicants for employment or current employees. Such efforts should be aimed at developing full journey level status employees in the type of trade or job classification involved.
  - b. Consistent with the contractor's work force requirements and as permissible under Federal and State regulations, the contractor shall make full use of training programs, i.e., apprenticeship, and on-the-job training programs for the geographical area of contract performance. In the event a special provision for training is provided under this contract, this subparagraph will be superseded as indicated in the special provision. The contracting agency may reserve training positions for persons who receive welfare assistance in accordance with 23 U.S.C. 140(a).
  - c. The contractor will advise employees and applicants for employment of available training programs and entrance requirements for each.
  - d. The contractor will periodically review the training and promotion potential of employees who are minorities and women and will encourage eligible employees to apply for such training and promotion.
7. **Unions:** If the contractor relies in whole or in part upon unions as a source of employees, the contractor will use good faith efforts to obtain the cooperation of such unions to increase opportunities for minorities and women. Actions by the contractor, either directly or through a contractor's association acting as agent, will include the procedures set forth below:
  - a. The contractor will use good faith efforts to develop, in cooperation with the unions, joint training programs aimed toward qualifying more minorities and women for membership in the unions and increasing the skills of minorities and women so that they may qualify for higher paying employment.
  - b. The contractor will use good faith efforts to incorporate an EEO clause into each union agreement to the end that such union will be contractually bound to refer applicants without regard to their race, color, religion, sex, national origin, age or disability.
  - c. The contractor is to obtain information as to the referral practices and policies of the labor union except that to the extent such information is within the exclusive possession of the labor union and such labor union refuses to furnish such information to the contractor, the contractor shall so certify to the contracting agency and shall set forth what efforts have been made to obtain such information.

- d. In the event the union is unable to provide the contractor with a reasonable flow of referrals within the time limit set forth in the collective bargaining agreement, the contractor will, through independent recruitment efforts, fill the employment vacancies without regard to race, color, religion, sex, national origin, age or disability; making full efforts to obtain qualified and/or qualifiable minorities and women. The failure of a union to provide sufficient referrals (even though it is obligated to provide exclusive referrals under the terms of a collective bargaining agreement) does not relieve the contractor from the requirements of this paragraph. In the event the union referral practice prevents the contractor from meeting the obligations pursuant to Executive Order 11246, as amended, and these special provisions, such contractor shall immediately notify the contracting agency.
8. **Reasonable Accommodation for Applicants / Employees with Disabilities:** The contractor must be familiar with the requirements for and comply with the Americans with Disabilities Act and all rules and regulations established there under. Employers must provide reasonable accommodation in all employment activities unless to do so would cause an undue hardship.
9. **Selection of Subcontractors, Procurement of Materials and Leasing of Equipment:** The contractor shall not discriminate on the grounds of race, color, religion, sex, national origin, age or disability in the selection and retention of subcontractors, including procurement of materials and leases of equipment. The contractor shall take all necessary and reasonable steps to ensure nondiscrimination in the administration of this contract.
- a. The contractor shall notify all potential subcontractors and suppliers and lessors of their EEO obligations under this contract.
- b. The contractor will use good faith efforts to ensure subcontractor compliance with their EEO obligations.
10. **Assurance Required by 49 CFR 26.13(b):**
- a. The requirements of 49 CFR Part 26 and the State DOT's U.S. DOT-approved DBE program are incorporated by reference.
- b. The contractor or subcontractor shall not discriminate on the basis of race, color, national origin, or sex in the performance of this contract. The contractor shall carry out applicable requirements of 49 CFR Part 26 in the award and administration of DOT-assisted contracts. Failure by the contractor to carry out these requirements is a material breach of this contract, which may result in the termination of this contract or such other remedy as the contracting agency deems appropriate.
11. **Records and Reports:** The contractor shall keep such records as necessary to document compliance with the EEO requirements. Such records shall be retained for a period of three years following the date of the final payment to the contractor for all contract work and shall be available at reasonable times and places for inspection by authorized representatives of the contracting agency and the FHWA.
- a. The records kept by the contractor shall document the following:
- (1) The number and work hours of minority and non-minority group members and women employed in each work classification on the project;
- (2) The progress and efforts being made in cooperation with unions, when applicable, to increase employment opportunities for minorities and women; and
- (3) The progress and efforts being made in locating, hiring, training, qualifying, and upgrading minorities and women;
- b. The contractors and subcontractors will submit an annual report to the contracting agency each July for the duration of the project, indicating the number of minority, women, and non-minority group employees currently engaged in each work classification required by the contract work. This information is to be reported on Form FHWA-1391. The staffing data should represent the project work force on board in all or any part of the last payroll period preceding the end of July. If on-the-job training is being required by special provision, the contractor will be required to collect and report training data. The employment data should reflect the work force on board during all or any part of the last payroll period preceding the end of July.

### III. NONSEGREGATED FACILITIES

This provision is applicable to all Federal-aid construction contracts and to all related construction subcontracts of \$10,000 or more.

The contractor must ensure that facilities provided for employees are provided in such a manner that segregation on the basis of race, color, religion, sex, or national origin cannot result. The contractor may neither require such segregated use by written or oral policies nor tolerate such use by employee custom. The contractor's obligation extends further to ensure that its employees are not assigned to perform their services at any location, under the contractor's control, where the facilities are segregated. The term "facilities" includes waiting rooms, work areas, restaurants and other eating areas, time clocks, restrooms, washrooms, locker rooms, and other storage or dressing areas, parking lots, drinking fountains, recreation or entertainment areas, transportation, and housing provided for employees. The contractor shall provide separate or single-user restrooms and necessary dressing or sleeping areas to assure privacy between sexes.

### IV. DAVIS-BACON AND RELATED ACT PROVISIONS

This section is applicable to all Federal-aid construction projects exceeding \$2,000 and to all related subcontracts and lower-tier subcontracts (regardless of subcontract size). The requirements apply to all projects located within the right-of-way of a roadway that is functionally classified as Federal-aid highway. This excludes roadways functionally classified as local roads or rural minor collectors, which are exempt. Contracting agencies may elect to apply these requirements to other projects.

The following provisions are from the U.S. Department of Labor regulations in 29 CFR 5.5 "Contract provisions and related matters" with minor revisions to conform to the FHWA-1273 format and FHWA program requirements.

#### 1. Minimum wages

- a. All laborers and mechanics employed or working upon the site of the work, will be paid unconditionally and not less often than once a week, and without subsequent deduction or rebate on any account (except such payroll deductions as are permitted by regulations issued by the Secretary of Labor under the Copeland Act (29 CFR part 3)), the full amount of wages and bona fide fringe benefits (or cash equivalents thereof) due at time of payment computed at rates not less than those contained in the wage determination of the Secretary of Labor which is attached hereto and made a part hereof, regardless of any contractual relationship which may be alleged to exist between the contractor and such laborers and mechanics.

Contributions made or costs reasonably anticipated for bona fide fringe benefits under section 1(b)(2) of the Davis-Bacon Act on behalf of laborers or mechanics are considered wages paid to such laborers or mechanics, subject to the provisions of paragraph 1.d. of this section; also, regular contributions made or costs incurred for more than a weekly period (but not less often than quarterly) under plans, funds, or programs which cover the particular weekly period, are deemed to be constructively made or incurred during such weekly period. Such laborers and mechanics shall be paid the appropriate wage rate and fringe benefits on the wage determination for the classification of work actually performed, without regard to skill, except as provided in 29 CFR 5.5(a)(4). Laborers or mechanics performing work in more than one classification may be compensated at the rate specified for each classification for the time actually worked therein: Provided, That the employer's payroll records accurately set forth the time spent in each classification in which work is performed. The wage determination (including any additional classification and wage rates conformed under paragraph 1.b. of this section) and the Davis-Bacon poster (WH-1321) shall be posted at all times by the contractor and its subcontractors at the site of the work in a prominent and accessible place where it can be easily seen by the workers.

- b. (1) The contracting officer shall require that any class of laborers or mechanics, including helpers, which is not listed in the wage determination and which is to be employed under the contract shall be classified in conformance with the wage determination. The contracting officer shall approve an additional classification and wage rate and fringe benefits therefore only when the following criteria have been met:
    - (i) The work to be performed by the classification requested is not performed by a classification in the wage determination; and
    - (ii) The classification is utilized in the area by the construction industry; and
    - (iii) The proposed wage rate, including any bona fide fringe benefits, bears a reasonable relationship to the wage rates contained in the wage determination.
  - (2) If the contractor and the laborers and mechanics to be employed in the classification (if known), or their representatives, and the contracting officer agree on the classification and wage rate (including the amount designated for fringe benefits where appropriate), a report of the action taken shall be sent by the contracting officer to the Administrator of the Wage and Hour Division, Employment Standards Administration, U.S. Department of Labor, Washington, DC 20210. The Administrator, or an authorized representative, will approve, modify, or disapprove every additional classification action within 30 days of receipt and so advise the contracting officer or will notify the contracting officer within the 30-day period that additional time is necessary.
  - (3) In the event the contractor, the laborers or mechanics to be employed in the classification or their representatives, and the contracting officer do not agree on the proposed classification and wage rate (including the amount designated for fringe benefits, where appropriate), the contracting officer shall refer the questions, including the views of all interested parties and the recommendation of the contracting officer, to the Wage and Hour Administrator for determination. The Wage and Hour Administrator, or an authorized representative, will issue a determination within 30 days of receipt and so advise the contracting officer or will notify the contracting officer within the 30-day period that additional time is necessary.
  - (4) The wage rate (including fringe benefits where appropriate) determined pursuant to paragraphs 1.b.(2) or 1.b.(3) of this section, shall be paid to all workers performing work in the classification under this contract from the first day on which work is performed in the classification.
- c. Whenever the minimum wage rate prescribed in the contract for a class of laborers or mechanics includes a fringe benefit which is not expressed as an hourly rate, the contractor shall either pay the benefit as stated in the wage determination or shall pay another bona fide fringe benefit or an hourly cash equivalent thereof.
  - d. If the contractor does not make payments to a trustee or other third person, the contractor may consider as part of the wages of any laborer or mechanic the amount of any costs reasonably anticipated in providing bona fide fringe benefits under a plan or program. Provided, That the Secretary of Labor has found, upon the written request of the contractor, that the applicable standards of the Davis-Bacon Act have been met. The Secretary of Labor may require the contractor to set aside in a separate account assets for the meeting of obligations under the plan or program.
2. **Withholding.** The contracting agency shall upon its own action or upon written request of an authorized representative of the Department of Labor, withhold or cause to be withheld from the contractor under this contract, or any other Federal contract with the same prime contractor, or any other federally-assisted contract subject to Davis-Bacon prevailing wage requirements, which is held by the same prime contractor, so much of the accrued payments or advances as may be considered necessary to pay laborers and mechanics, including apprentices, trainees, and helpers, employed by the contractor or any subcontractor the full amount of wages required by the contract. In the event of failure to pay any laborer or mechanic, including any apprentice, trainee, or helper, employed or working on the site of the work, all or part of the wages required by the contract, the contracting agency may, after written notice to the contractor, take such action as may be necessary to cause the suspension of any further payment, advance, or guarantee of funds until such violations have ceased.
  3. **Payrolls and basic records**
    - a. Payrolls and basic records relating thereto shall be maintained by the contractor during the course of the work and preserved for a period of three years thereafter for all laborers and mechanics working at the site of the work. Such records shall contain the name, address, and social security number of each such worker, his or her correct classification, hourly rates of wages paid (including rates of contributions or costs anticipated for bona fide fringe benefits or cash equivalents thereof of the types described in section 1(b)(2)(B) of the Davis-Bacon Act), daily and weekly number of hours worked, deductions made and actual wages paid. Whenever the Secretary of Labor has found under 29 CFR 5.5(a)(1)(iv) that the wages of any laborer or mechanic include the amount of any costs reasonably anticipated in providing benefits under a plan or program described in section 1(b)(2)(B) of the Davis-Bacon Act, the contractor shall maintain records which show that the commitment to provide such benefits is enforceable, that the plan or program is financially responsible, and that the plan or program has been communicated in writing to the laborers or mechanics affected, and records which show the costs anticipated or the actual cost incurred in providing such benefits. Contractors employing apprentices or trainees under approved programs shall maintain written evidence of the registration of apprenticeship programs and certification of trainee programs, the registration of the apprentices and trainees, and the ratios and wage rates prescribed in the applicable programs.
    - b. (1) The contractor shall submit weekly for each week in which any contract work is performed a copy of all payrolls to the contracting agency. The payrolls submitted shall set out accurately and completely all of the information required to be maintained under 29 CFR 5.5(a)(3)(i), except that full social security numbers and home addresses shall not be included on weekly transmittals. Instead the payrolls shall only need to include an individually identifying number for each employee ( e.g. , the last four digits of the employee's social security number). The required weekly payroll information may be submitted in any form desired. Optional Form WH-347 is available for this purpose from the Wage and Hour Division Web site at <http://www.dol.gov/esa/whd/forms/wh347instr.htm> or its successor site. The prime contractor is responsible for the submission of copies of payrolls by all subcontractors. Contractors and subcontractors shall maintain the full social security number and current address of each covered worker, and shall provide them upon request to the contracting agency for transmission to the State DOT, the FHWA or the Wage and Hour Division of the Department of Labor for purposes of an investigation or audit of compliance with prevailing wage requirements. It is not a violation of this section for a prime contractor to require a subcontractor to provide addresses and social security numbers to the prime contractor for its own records, without weekly submission to the contracting agency.
    - (2) Each payroll submitted shall be accompanied by a "Statement of Compliance," signed by the contractor or subcontractor or his or her agent who pays or supervises the payment of the persons employed under the contract and shall certify the following:
      - (i) That the payroll for the payroll period contains the information required to be provided under §5.5 (a)(3)(ii) of Regulations, 29 CFR part 5, the appropriate information is being maintained under §5.5 (a)(3)(i) of Regulations, 29 CFR part 5, and that such information is correct and complete;
      - (ii) That each laborer or mechanic (including each helper, apprentice, and trainee) employed on the contract during the payroll period has been paid the full weekly wages earned, without rebate, either directly or indirectly, and that no deductions have been made either directly or indirectly from the full wages earned, other than permissible deductions as set forth in Regulations, 29 CFR part 3;
      - (iii) That each laborer or mechanic has been paid not less than the applicable wage rates and fringe benefits or cash equivalents for the classification of work performed, as specified in the applicable wage determination incorporated into the contract.

- (3) The weekly submission of a properly executed certification set forth on the reverse side of Optional Form WH-347 shall satisfy the requirement for submission of the "Statement of Compliance" required by paragraph 3.b.(2) of this section.
- (4) The falsification of any of the above certifications may subject the contractor or subcontractor to civil or criminal prosecution under section 1001 of title 18 and section 231 of title 31 of the United States Code.
- c. The contractor or subcontractor shall make the records required under paragraph 3.a. of this section available for inspection, copying, or transcription by authorized representatives of the contracting agency, the State DOT, the FHWA, or the Department of Labor, and shall permit such representatives to interview employees during working hours on the job. If the contractor or subcontractor fails to submit the required records or to make them available, the FHWA may, after written notice to the contractor, the contracting agency or the State DOT, take such action as may be necessary to cause the suspension of any further payment, advance, or guarantee of funds. Furthermore, failure to submit the required records upon request or to make such records available may be grounds for debarment action pursuant to 29 CFR 5.12.
4. **Apprentices and trainees**
- a. Apprentices (programs of the USDOL). Apprentices will be permitted to work at less than the predetermined rate for the work they performed when they are employed pursuant to and individually registered in a bona fide apprenticeship program registered with the U.S. Department of Labor, Employment and Training Administration, Office of Apprenticeship Training, Employer and Labor Services, or with a State Apprenticeship Agency recognized by the Office, or if a person is employed in his or her first 90 days of probationary employment as an apprentice in such an apprenticeship program, who is not individually registered in the program, but who has been certified by the Office of Apprenticeship Training, Employer and Labor Services or a State Apprenticeship Agency (where appropriate) to be eligible for probationary employment as an apprentice.
- The allowable ratio of apprentices to journeymen on the job site in any craft classification shall not be greater than the ratio permitted to the contractor as to the entire work force under the registered program. Any worker listed on a payroll at an apprentice wage rate, who is not registered or otherwise employed as stated above, shall be paid not less than the applicable wage rate on the wage determination for the classification of work actually performed. In addition, any apprentice performing work on the job site in excess of the ratio permitted under the registered program shall be paid not less than the applicable wage rate on the wage determination for the work actually performed. Where a contractor is performing construction on a project in a locality other than that in which its program is registered, the ratios and wage rates (expressed in percentages of the journeyman's hourly rate) specified in the contractor's or subcontractor's registered program shall be observed.
- Every apprentice must be paid at not less than the rate specified in the registered program for the apprentice's level of progress, expressed as a percentage of the journeymen hourly rate specified in the applicable wage determination. Apprentices shall be paid fringe benefits in accordance with the provisions of the apprenticeship program. If the apprenticeship program does not specify fringe benefits, apprentices must be paid the full amount of fringe benefits listed on the wage determination for the applicable classification. If the Administrator determines that a different practice prevails for the applicable apprentice classification, fringes shall be paid in accordance with that determination.
- In the event the Office of Apprenticeship Training, Employer and Labor Services, or a State Apprenticeship Agency recognized by the Office, withdraws approval of an apprenticeship program, the contractor will no longer be permitted to utilize apprentices at less than the applicable predetermined rate for the work performed until an acceptable program is approved.
- b. Trainees (programs of the USDOL). Except as provided in 29 CFR 5.16, trainees will not be permitted to work at less than the predetermined rate for the work performed unless they are employed pursuant to and individually registered in a program which has received prior approval, evidenced by formal certification by the U.S. Department of Labor, Employment and Training Administration.
- The ratio of trainees to journeymen on the job site shall not be greater than permitted under the plan approved by the Employment and Training Administration.
- Every trainee must be paid at not less than the rate specified in the approved program for the trainee's level of progress, expressed as a percentage of the journeyman hourly rate specified in the applicable wage determination. Trainees shall be paid fringe benefits in accordance with the provisions of the trainee program. If the trainee program does not mention fringe benefits, trainees shall be paid the full amount of fringe benefits listed on the wage determination unless the Administrator of the Wage and Hour Division determines that there is an apprenticeship program associated with the corresponding journeyman wage rate on the wage determination which provides for less than full fringe benefits for apprentices. Any employee listed on the payroll at a trainee rate who is not registered and participating in a training plan approved by the Employment and Training Administration shall be paid not less than the applicable wage rate on the wage determination for the classification of work actually performed. In addition, any trainee performing work on the job site in excess of the ratio permitted under the registered program shall be paid not less than the applicable wage rate on the wage determination for the work actually performed.
- In the event the Employment and Training Administration withdraws approval of a training program, the contractor will no longer be permitted to utilize trainees at less than the applicable predetermined rate for the work performed until an acceptable program is approved.
- c. Equal employment opportunity. The utilization of apprentices, trainees and journeymen under this part shall be in conformity with the equal employment opportunity requirements of Executive Order 11246, as amended, and 29 CFR part 30.
- d. Apprentices and Trainees (programs of the U.S. DOT). Apprentices and trainees working under apprenticeship and skill training programs which have been certified by the Secretary of Transportation as promoting EEO in connection with Federal-aid highway construction programs are not subject to the requirements of paragraph 4 of this Section IV. The straight time hourly wage rates for apprentices and trainees under such programs will be established by the particular programs. The ratio of apprentices and trainees to journeymen shall not be greater than permitted by the terms of the particular program.
5. **Compliance with Copeland Act requirements.** The contractor shall comply with the requirements of 29 CFR part 3, which are incorporated by reference in this contract.
6. **Subcontracts.** The contractor or subcontractor shall insert Form FHWA-1273 in any subcontracts and also require the subcontractors to include Form FHWA-1273 in any lower tier subcontracts. The prime contractor shall be responsible for the compliance by any subcontractor or lower tier subcontractor with all the contract clauses in 29 CFR 5.5.
7. **Contract termination:** debarment. A breach of the contract clauses in 29 CFR 5.5 may be grounds for termination of the contract, and for debarment as a contractor and a subcontractor as provided in 29 CFR 5.12.
8. **Compliance with Davis-Bacon and Related Act requirements.** All rulings and interpretations of the Davis-Bacon and Related Acts contained in 29 CFR parts 1, 3, and 5 are herein incorporated by reference in this contract.
9. **Disputes concerning labor standards.** Disputes arising out of the labor standards provisions of this contract shall not be subject to the general disputes clause of this contract. Such disputes shall be resolved in accordance with the procedures of the Department of Labor set forth in 29 CFR parts 5, 6, and 7. Disputes within the meaning of this clause include disputes between the contractor (or any of its subcontractors) and the contracting agency, the U.S. Department of Labor, or the employees or their representatives.
10. **Certification of eligibility.**
- a. By entering into this contract, the contractor certifies that neither it (nor he or she) nor any person or firm who has an interest in the contractor's firm is a person or firm ineligible to be awarded Government contracts by virtue of section 3(a) of the Davis-Bacon Act or 29 CFR 5.12(a)(1).

- b. No part of this contract shall be subcontracted to any person or firm ineligible for award of a Government contract by virtue of section 3(a) of the Davis-Bacon Act or 29 CFR 5.12(a)(1).
- c. The penalty for making false statements is prescribed in the U.S. Criminal Code, 18 U.S.C. 1001.

#### V. CONTRACT WORK HOURS AND SAFETY STANDARDS ACT

The following clauses apply to any Federal-aid construction contract in an amount in excess of \$100,000 and subject to the overtime provisions of the Contract Work Hours and Safety Standards Act. These clauses shall be inserted in addition to the clauses required by 29 CFR 5.5(a) or 29 CFR 4.6. As used in this paragraph, the terms laborers and mechanics include watchmen and guards.

1. **Overtime requirements.** No contractor or subcontractor contracting for any part of the contract work which may require or involve the employment of laborers or mechanics shall require or permit any such laborer or mechanic in any workweek in which he or she is employed on such work to work in excess of forty hours in such workweek unless such laborer or mechanic receives compensation at a rate not less than one and one-half times the basic rate of pay for all hours worked in excess of forty hours in such workweek.
2. **Violation; liability for unpaid wages; liquidated damages.** In the event of any violation of the clause set forth in paragraph (1.) of this section, the contractor and any subcontractor responsible therefor shall be liable for the unpaid wages. In addition, such contractor and subcontractor shall be liable to the United States (in the case of work done under contract for the District of Columbia or a territory, to such District or to such territory), for liquidated damages. Such liquidated damages shall be computed with respect to each individual laborer or mechanic, including watchmen and guards, employed in violation of the clause set forth in paragraph (1.) of this section, in the sum of \$10 for each calendar day on which such individual was required or permitted to work in excess of the standard workweek of forty hours without payment of the overtime wages required by the clause set forth in paragraph (1.) of this section.
3. **Withholding for unpaid wages and liquidated damages.** The FHWA or the contracting agency shall upon its own action or upon written request of an authorized representative of the Department of Labor withhold or cause to be withheld, from any moneys payable on account of work performed by the contractor or subcontractor under any such contract or any other Federal contract with the same prime contractor, or any other federally-assisted contract subject to the Contract Work Hours and Safety Standards Act, which is held by the same prime contractor, such sums as may be determined to be necessary to satisfy any liabilities of such contractor or subcontractor for unpaid wages and liquidated damages as provided in the clause set forth in paragraph (2.) of this section.
4. **Subcontracts.** The contractor or subcontractor shall insert in any subcontracts the clauses set forth in paragraph (1.) through (4.) of this section and also a clause requiring the subcontractors to include these clauses in any lower tier subcontracts. The prime contractor shall be responsible for compliance by any subcontractor or lower tier subcontractor with the clauses set forth in paragraphs (1.) through (4.) of this section.

#### VI. SUBLETTING OR ASSIGNING THE CONTRACT

This provision is applicable to all Federal-aid construction contracts on the National Highway System.

1. The contractor shall perform with its own organization contract work amounting to not less than 30 percent (or a greater percentage if specified elsewhere in the contract) of the total original contract price, excluding any specialty items designated by the contracting agency. Specialty items may be performed by subcontract and the amount of any such specialty items performed may be deducted from the total original contract price before computing the amount of work required to be performed by the contractor's own organization (23 CFR 635.116).
  - a. The term "perform work with its own organization" refers to workers employed or leased by the prime contractor, and equipment owned or rented by the prime contractor, with or without operators. Such term does not include employees or equipment of a subcontractor or lower tier subcontractor, agents of the prime contractor, or any other assignees. The term may include payments for the costs of hiring leased employees

from an employee leasing firm meeting all relevant Federal and State regulatory requirements. Leased employees may only be included in this term if the prime contractor meets all of the following conditions:

- (1) the prime contractor maintains control over the supervision of the day-to-day activities of the leased employees;
  - (2) the prime contractor remains responsible for the quality of the work of the leased employees;
  - (3) the prime contractor retains all power to accept or exclude individual employees from work on the project; and
  - (4) the prime contractor remains ultimately responsible for the payment of predetermined minimum wages, the submission of payrolls, statements of compliance and all other Federal regulatory requirements.
- b. "Specialty Items" shall be construed to be limited to work that requires highly specialized knowledge, abilities, or equipment not ordinarily available in the type of contracting organizations qualified and expected to bid or propose on the contract as a whole and in general are to be limited to minor components of the overall contract.
2. The contract amount upon which the requirements set forth in paragraph (1) of Section VI is computed includes the cost of material and manufactured products which are to be purchased or produced by the contractor under the contract provisions.
  3. The contractor shall furnish (a) a competent superintendent or supervisor who is employed by the firm, has full authority to direct performance of the work in accordance with the contract requirements, and is in charge of all construction operations (regardless of who performs the work) and (b) such other of its own organizational resources (supervision, management, and engineering services) as the contracting officer determines is necessary to assure the performance of the contract.
  4. No portion of the contract shall be sublet, assigned or otherwise disposed of except with the written consent of the contracting officer, or authorized representative, and such consent when given shall not be construed to relieve the contractor of any responsibility for the fulfillment of the contract. Written consent will be given only after the contracting agency has assured that each subcontract is evidenced in writing and that it contains all pertinent provisions and requirements of the prime contract.
  5. The 30% self-performance requirement of paragraph (1) is not applicable to design-build contracts; however, contracting agencies may establish their own self-performance requirements.

#### **VII. SAFETY: ACCIDENT PREVENTION**

This provision is applicable to all Federal-aid construction contracts and to all related subcontracts.

1. In the performance of this contract the contractor shall comply with all applicable Federal, State, and local laws governing safety, health, and sanitation (23 CFR 635). The contractor shall provide all safeguards, safety devices and protective equipment and take any other needed actions as it determines, or as the contracting officer may determine, to be reasonably necessary to protect the life and health of employees on the job and the safety of the public and to protect property in connection with the performance of the work covered by the contract.
2. It is a condition of this contract, and shall be made a condition of each subcontract, which the contractor enters into pursuant to this contract, that the contractor and any subcontractor shall not permit any employee, in performance of the contract, to work in surroundings or under conditions which are unsanitary, hazardous or dangerous to his/her health or safety, as determined under construction safety and health standards (29 CFR 1926) promulgated by the Secretary of Labor, in accordance with Section 107 of the Contract Work Hours and Safety Standards Act (40 U.S.C. 3704).
3. Pursuant to 29 CFR 1926.3, it is a condition of this contract that the Secretary of Labor or authorized representative thereof, shall have right of entry to any site of contract performance to inspect or investigate the matter of compliance with the construction safety and health standards and to carry out the duties of the Secretary under Section 107 of the Contract Work Hours and Safety Standards Act (40 U.S.C.3704).

#### **VIII. FALSE STATEMENTS CONCERNING HIGHWAY PROJECTS**

This provision is applicable to all Federal-aid construction contracts and to all related subcontracts.

In order to assure high quality and durable construction in conformity with approved plans and specifications and a high degree of reliability on statements and representations made by engineers, contractors, suppliers, and workers on Federal-aid highway projects, it is essential that all persons concerned with the project perform their functions as carefully, thoroughly, and honestly as possible. Willful falsification, distortion, or misrepresentation with respect to any facts related to the project is a violation of Federal law. To prevent any misunderstanding regarding the seriousness of these and similar acts, Form FHWA-1022 shall be posted on each Federal-aid highway project (23 CFR 635) in one or more places where it is readily available to all persons concerned with the project:

18 U.S.C. 1020 reads as follows:

"Whoever, being an officer, agent, or employee of the United States, or of any State or Territory, or whoever, whether a person, association, firm, or corporation, knowingly makes any false statement, false representation, or false report as to the character, quality, quantity, or cost of the material used or to be used, or the quantity or quality of the work performed or to be performed, or the cost thereof in connection with the submission of plans, maps, specifications, contracts, or costs of construction on any highway or related project submitted for approval to the Secretary of Transportation; or

Whoever knowingly makes any false statement, false representation, false report or false claim with respect to the character, quality, quantity, or cost of any work performed or to be performed, or materials furnished or to be furnished, in connection with the construction of any highway or related project approved by the Secretary of Transportation; or

Whoever knowingly makes any false statement or false representation as to material fact in any statement, certificate, or report submitted pursuant to provisions of the Federal-aid Roads Act approved July 1, 1916, (39 Stat. 355), as amended and supplemented;

Shall be fined under this title or imprisoned not more than 5 years or both."

#### **IX. IMPLEMENTATION OF CLEAN AIR ACT AND FEDERAL WATER POLLUTION CONTROL ACT**

This provision is applicable to all Federal-aid construction contracts and to all related subcontracts.

By submission of this bid/proposal or the execution of this contract, or subcontract, as appropriate, the bidder, proposer, Federal-aid construction contractor, or subcontractor, as appropriate, will be deemed to have stipulated as follows:

1. That any person who is or will be utilized in the performance of this contract is not prohibited from receiving an award due to a violation of Section 508 of the Clean Water Act or Section 306 of the Clean Air Act.
2. That the contractor agrees to include or cause to be included the requirements of paragraph (1) of this Section X in every subcontract, and further agrees to take such action as the contracting agency may direct as a means of enforcing such requirements.

#### **X. CERTIFICATION REGARDING DEBARMENT, SUSPENSION, INELIGIBILITY AND VOLUNTARY EXCLUSION**



This provision is applicable to all Federal-aid construction contracts, design-build contracts, subcontracts, lower-tier subcontracts, purchase orders, lease agreements, consultant contracts or any other covered transaction requiring FHWA approval or that is estimated to cost \$25,000 or more – as defined in 2 CFR Parts 180 and 1200.

**1. Instructions for Certification – First Tier Participants:**

- a. By signing and submitting this proposal, the prospective first tier participant is providing the certification set out below.
- b. The inability of a person to provide the certification set out below will not necessarily result in denial of participation in this covered transaction. The prospective first tier participant shall submit an explanation of why it cannot provide the certification set out below. The certification or explanation will be considered in connection with the department or agency's determination whether to enter into this transaction. However, failure of the prospective first tier participant to furnish a certification or an explanation shall disqualify such a person from participation in this transaction.
- c. The certification in this clause is a material representation of fact upon which reliance was placed when the contracting agency determined to enter into this transaction. If it is later determined that the prospective participant knowingly rendered an erroneous certification, in addition to other remedies available to the Federal Government, the contracting agency may terminate this transaction for cause of default.
- d. The prospective first tier participant shall provide immediate written notice to the contracting agency to whom this proposal is submitted if any time the prospective first tier participant learns that its certification was erroneous when submitted or has become erroneous by reason of changed circumstances.
- e. The terms "covered transaction," "debarred," "suspended," "ineligible," "participant," "person," "principal," and "voluntarily excluded," as used in this clause, are defined in 2 CFR Parts 180 and 1200. "First Tier Covered Transactions" refers to any covered transaction between a grantee or subgrantee of Federal funds and a participant (such as the prime or general contract). "Lower Tier Covered Transactions" refers to any covered transaction under a First Tier Covered Transaction (such as subcontracts). "First Tier Participant" refers to the participant who has entered into a covered transaction with a grantee or subgrantee of Federal funds (such as the prime or general contractor). "Lower Tier Participant" refers any participant who has entered into a covered transaction with a First Tier Participant or other Lower Tier Participants (such as subcontractors and suppliers).
- f. The prospective first tier participant agrees by submitting this proposal that, should the proposed covered transaction be entered into, it shall not knowingly enter into any lower tier covered transaction with a person who is debarred, suspended, declared ineligible, or voluntarily excluded from participation in this covered transaction, unless authorized by the department or agency entering into this transaction.
- g. The prospective first tier participant further agrees by submitting this proposal that it will include the clause titled "Certification Regarding Debarment, Suspension, Ineligibility and Voluntary Exclusion-Lower Tier Covered Transactions," provided by the department or contracting agency, entering into this covered transaction, without modification, in all lower tier covered transactions and in all solicitations for lower tier covered transactions exceeding the \$25,000 threshold.
- h. A participant in a covered transaction may rely upon a certification of a prospective participant in a lower tier covered transaction that is not debarred, suspended, ineligible, or voluntarily excluded from the covered transaction, unless it knows that the certification is erroneous. A participant is responsible for ensuring that its principals are not suspended, debarred, or otherwise ineligible to participate in covered transactions. To verify the eligibility of its principals, as well as the eligibility of any lower tier prospective participants, each participant may, but is not required to, check the Excluded Parties List System website (<https://www.epls.gov/>), which is compiled by the General Services Administration.
- i. Nothing contained in the foregoing shall be construed to require the establishment of a system of records in order to render in good faith the certification required by this clause. The knowledge and information of the prospective participant is not required to exceed that which is normally possessed by a prudent person in the ordinary course of business dealings.
- j. Except for transactions authorized under paragraph (f) of these instructions, if a participant in a covered transaction knowingly enters into a lower tier covered transaction with a person who is suspended, debarred, ineligible, or voluntarily excluded from participation in this transaction, in addition to other remedies available to the Federal Government, the department or agency may terminate this transaction for cause or default.

\* \* \* \* \*

**2. Certification Regarding Debarment, Suspension, Ineligibility and Voluntary Exclusion – First Tier Participants:**

- a. The prospective first tier participant certifies to the best of its knowledge and belief, that it and its principals:
  - (1) Are not presently debarred, suspended, proposed for debarment, declared ineligible, or voluntarily excluded from participating in covered transactions by any Federal department or agency;
  - (2) Have not within a three-year period preceding this proposal been convicted of or had a civil judgment rendered against them for commission of fraud or a criminal offense in connection with obtaining, attempting to obtain, or performing a public (Federal, State or local) transaction or contract under a public transaction; violation of Federal or State antitrust statutes or commission of embezzlement, theft, forgery, bribery, falsification or destruction of records, making false statements, or receiving stolen property;
  - (3) Are not presently indicted for or otherwise criminally or civilly charged by a governmental entity (Federal, State or local) with commission of any of the offenses enumerated in paragraph (a)(2) of this certification; and
  - (4) Have not within a three-year period preceding this application/proposal had one or more public transactions (Federal, State or local) terminated for cause or default.
- b. Where the prospective participant is unable to certify to any of the statements in this certification, such prospective participant shall attach an explanation to this proposal.

**2. Instructions for Certification - Lower Tier Participants:**

(Applicable to all subcontracts, purchase orders and other lower tier transactions requiring prior FHWA approval or estimated to cost \$25,000 or more - 2 CFR Parts 180 and 1200)

- a. By signing and submitting this proposal, the prospective lower tier is providing the certification set out below.
- b. The certification in this clause is a material representation of fact upon which reliance was placed when this transaction was entered into. If it is later determined that the prospective lower tier participant knowingly rendered an erroneous certification, in addition to other remedies available to the Federal Government, the department, or agency with which this transaction originated may pursue available remedies, including suspension and/or debarment.
- c. The prospective lower tier participant shall provide immediate written notice to the person to which this proposal is submitted if at any time the prospective lower tier participant learns that its certification was erroneous by reason of changed circumstances.
- d. The terms "covered transaction," "debarred," "suspended," "ineligible," "participant," "person," "principal," and "voluntarily excluded," as used in this clause, are defined in 2 CFR Parts 180 and 1200. You may contact the person to which this proposal is submitted for assistance in obtaining a copy of those regulations. "First Tier Covered Transactions" refers to any covered transaction between a grantee or subgrantee of

Federal funds and a participant (such as the prime or general contract). "Lower Tier Covered Transactions" refers to any covered transaction under a First Tier Covered Transaction (such as subcontracts). "First Tier Participant" refers to the participant who has entered into a covered transaction with a grantee or subgrantee of Federal funds (such as the prime or general contractor). "Lower Tier Participant" refers any participant who has entered into a covered transaction with a First Tier Participant or other Lower Tier Participants (such as subcontractors and suppliers).

- e. The prospective lower tier participant agrees by submitting this proposal that, should the proposed covered transaction be entered into, it shall not knowingly enter into any lower tier covered transaction with a person who is debarred, suspended, declared ineligible, or voluntarily excluded from participation in this covered transaction, unless authorized by the department or agency with which this transaction originated.
- f. The prospective lower tier participant further agrees by submitting this proposal that it will include this clause titled "Certification Regarding Debarment, Suspension, Ineligibility and Voluntary Exclusion-Lower Tier Covered Transaction," without modification, in all lower tier covered transactions and in all solicitations for lower tier covered transactions exceeding the \$25,000 threshold.
- g. A participant in a covered transaction may rely upon a certification of a prospective participant in a lower tier covered transaction that is not debarred, suspended, ineligible, or voluntarily excluded from the covered transaction, unless it knows that the certification is erroneous. A participant is responsible for ensuring that its principals are not suspended, debarred, or otherwise ineligible to participate in covered transactions. To verify the eligibility of its principals, as well as the eligibility of any lower tier prospective participants, each participant may, but is not required to, check the Excluded Parties List System website (<https://www.epls.gov/>), which is compiled by the General Services Administration.
- h. Nothing contained in the foregoing shall be construed to require establishment of a system of records in order to render in good faith the certification required by this clause. The knowledge and information of participant is not required to exceed that which is normally possessed by a prudent person in the ordinary course of business dealings.
- i. Except for transactions authorized under paragraph e of these instructions, if a participant in a covered transaction knowingly enters into a lower tier covered transaction with a person who is suspended, debarred, ineligible, or voluntarily excluded from participation in this transaction, in addition to other remedies available to the Federal Government, the department or agency with which this transaction originated may pursue available remedies, including suspension and/or debarment.

\* \* \* \* \*

**Certification Regarding Debarment, Suspension, Ineligibility and Voluntary Exclusion--Lower Tier Participants:**

- 1. The prospective lower tier participant certifies, by submission of this proposal, that neither it nor its principals is presently debarred, suspended, proposed for debarment, declared ineligible, or voluntarily excluded from participating in covered transactions by any Federal department or agency.
- 2. Where the prospective lower tier participant is unable to certify to any of the statements in this certification, such prospective participant shall attach an explanation to this proposal.

\* \* \* \* \*

**XI. CERTIFICATION REGARDING USE OF CONTRACT FUNDS FOR LOBBYING**

This provision is applicable to all Federal-aid construction contracts and to all related subcontracts which exceed \$100,000 (49 CFR 20).

- 1. The prospective participant certifies, by signing and submitting this bid or proposal, to the best of his or her knowledge and belief, that:
  - a. No Federal appropriated funds have been paid or will be paid, by or on behalf of the undersigned, to any person for influencing or attempting to influence an officer or employee of any Federal agency, a Member of Congress, an officer or employee of Congress, or an employee of a Member of Congress in connection with the awarding of any Federal contract, the making of any Federal grant, the making of any Federal loan, the entering into of any cooperative agreement, and the extension, continuation, renewal, amendment, or modification of any Federal contract, grant, loan, or cooperative agreement.
  - b. If any funds other than Federal appropriated funds have been paid or will be paid to any person for influencing or attempting to influence an officer or employee of any Federal agency, a Member of Congress, an officer or employee of Congress, or an employee of a Member of Congress in connection with this Federal contract, grant, loan, or cooperative agreement, the undersigned shall complete and submit Standard Form-LLL, "Disclosure Form to Report Lobbying," in accordance with its instructions.
- 2. This certification is a material representation of fact upon which reliance was placed when this transaction was made or entered into. Submission of this certification is a prerequisite for making or entering into this transaction imposed by 31 U.S.C. 1352. Any person who fails to file the required certification shall be subject to a civil penalty of not less than \$10,000 and not more than \$100,000 for each such failure.
- 3. The prospective participant also agrees by submitting its bid or proposal that the participant shall require that the language of this certification be included in all lower tier subcontracts, which exceed \$100,000 and that all such recipients shall certify and disclose accordingly.

**STANDARD SPECIAL PROVISION****ON-THE-JOB TRAINING**

(10-16-07) (Rev. 4-21-15)

Z-10

**Description**

The North Carolina Department of Transportation will administer a custom version of the Federal On-the-Job Training (OJT) Program, commonly referred to as the Alternate OJT Program. All contractors (existing and newcomers) will be automatically placed in the Alternate Program. Standard OJT requirements typically associated with individual projects will no longer be applied at the project level. Instead, these requirements will be applicable on an annual basis for each contractor administered by the OJT Program Manager.

On the Job Training shall meet the requirements of 23 CFR 230.107 (b), 23 USC – Section 140, this provision and the On-the-Job Training Program Manual.

The Alternate OJT Program will allow a contractor to train employees on Federal, State and privately funded projects located in North Carolina. However, priority shall be given to training employees on NCDOT Federal-Aid funded projects.

**Minorities and Women**

Developing, training and upgrading of minorities and women toward journeyman level status is a primary objective of this special training provision. Accordingly, the Contractor shall make every effort to enroll minority and women as trainees to the extent that such persons are available within a reasonable area of recruitment. This training commitment is not intended, and shall not be used, to discriminate against any applicant for training, whether a member of a minority group or not.

**Assigning Training Goals**

The Department, through the OJT Program Manager, will assign training goals for a calendar year based on the contractors' past three years' activity and the contractors' anticipated upcoming year's activity with the Department. At the beginning of each year, all contractors eligible will be contacted by the Department to determine the number of trainees that will be assigned for the upcoming calendar year. At that time the Contractor shall enter into an agreement with the Department to provide a self-imposed on-the-job training program for the calendar year. This agreement will include a specific number of annual training goals agreed to by both parties. The number of training assignments may range from 1 to 15 per contractor per calendar year. The Contractor shall sign an agreement to fulfill their annual goal for the year.\

**Training Classifications**

The Contractor shall provide on-the-job training aimed at developing full journeyman level workers in the construction craft/operator positions. Preference shall be given to providing training in the following skilled work classifications:

Equipment Operators	Office Engineers
Truck Drivers	Estimators
Carpenters	Iron / Reinforcing Steel Workers
Concrete Finishers	Mechanics
Pipe Layers	Welders

The Department has established common training classifications and their respective training requirements that may be used by the contractors. However, the classifications established are not all-inclusive. Where the training is oriented toward construction applications, training will be allowed in lower-level management positions such as office engineers and estimators. Contractors shall submit new classifications for specific job functions that their employees are performing. The Department will review and recommend for acceptance to FHWA the new classifications proposed by contractors, if applicable. New classifications shall meet the following requirements:

Proposed training classifications are reasonable and realistic based on the job skill classification needs, and

The number of training hours specified in the training classification is consistent with common practices and provides enough time for the trainee to obtain journeyman level status.

The Contractor may allow trainees to be trained by a subcontractor provided that the Contractor retains primary responsibility for meeting the training and this provision is made applicable to the subcontract. However, only the Contractor will receive credit towards the annual goal for the trainee.

Where feasible, 25 percent of apprentices or trainees in each occupation shall be in their first year of apprenticeship or training. The number of trainees shall be distributed among the work classifications on the basis of the contractor's needs and the availability of journeymen in the various classifications within a reasonable area of recruitment.

No employee shall be employed as a trainee in any classification in which they have successfully completed a training course leading to journeyman level status or in which they have been employed as a journeyman.

**Records and Reports**

The Contractor shall maintain enrollment, monthly and completion reports documenting company compliance under these contract documents. These documents and any other information as requested shall be submitted to the OJT Program Manager.

Upon completion and graduation of the program, the Contractor shall provide each trainee with a certification Certificate showing the type and length of training satisfactorily completed.

**Trainee Interviews**

All trainees enrolled in the program will receive an initial and Trainee/Post graduate interview conducted by the OJT program staff.

**Trainee Wages**

Contractors shall compensate trainees on a graduating pay scale based upon a percentage of the prevailing minimum journeyman wages (Davis-Bacon Act). Minimum pay shall be as follows:

60 percent	of the journeyman wage for the first half of the training period
75 percent	of the journeyman wage for the third quarter of the training period
90 percent	of the journeyman wage for the last quarter of the training period

In no instance shall a trainee be paid less than the local minimum wage. The Contractor shall adhere to the minimum hourly wage rate that will satisfy both the NC Department of Labor (NCDOL) and the Department.

**Achieving or Failing to Meet Training Goals**

The Contractor will be credited for each trainee employed by him on the contract work who is currently enrolled or becomes enrolled in an approved program and who receives training for at least 50 percent of the specific program requirement. Trainees will be allowed to be transferred between projects if required by the Contractor's scheduled workload to meet training goals.

If a contractor fails to attain their training assignments for the calendar year, they may be taken off the NCDOT's Bidders List.

**Measurement and Payment**

No compensation will be made for providing required training in accordance with these contract documents.

**STANDARD SPECIAL PROVISION**  
**MINIMUM WAGES**  
**GENERAL DECISION NC180101 01/05/2018 NC101**

Z-101

Date: January 5, 2018

General Decision Number: NC180101 01/05/2018 NC101

Superseded General Decision Numbers: NC20170101

State: North Carolina

Construction Type: HIGHWAY

**COUNTIES:**

Alamance	Forsyth	Randolph
Anson	Gaston	Rockingham
Cabarrus	Guilford	Stokes
Chatham	Mecklenburg	Union
Davie	Orange	Yadkin
Durham	Person	

HIGHWAY CONSTRUCTION PROJECTS (excluding tunnels, building structures in rest area projects & railroad construction; bascule, suspension & spandrel arch bridges designed for commercial navigation, bridges involving marine construction; and other major bridges).

Note: Under Executive Order (EO) 13658, an hourly minimum wage of \$10.35 for calendar year 2018 applies to all contracts subject to the Davis-Bacon Act for which the contract is awarded (and any solicitation was issued) on or after January 1, 2015. If this contract is covered by the EO, the contractor must pay all workers in any classification listed on this wage determination at least \$10.35 per hour (or the applicable wage rate listed on this wage determination, if it is higher) for all hours spent performing on the contract for calendar year 2018. The EO minimum wage rate will be adjusted annually. Please note that this EO applies to the above-mentioned types of contracts entered into by the federal government that are subject to the Davis-Bacon Act itself, but it does not apply to contracts subject only to the Davis-Bacon Related Acts, including those set forth at 29 CFR 5.1(a)(2) – (60). Additional information on contractor requirements and worker protections under the EO is available at [www.dol.gov/whd/govcontracts](http://www.dol.gov/whd/govcontracts).

Modification Number  
0

Publication Date  
01/05/2018

SUNC2014-003 11/14/2014

	Rates	Fringes
BLASTER	18.64	
CARPENTER	13.68	.05
CEMENT MASON/CONCRETE FINISHER	13.93	
ELECTRICIAN		
Electrician	18.79	2.72
Telecommunications Technician	15.19	1.25
IRONWORKER	13.30	
LABORER		
Asphalt Raker and Spreader	12.78	

	Rates	Fringes
Asphalt Screed/Jackman	14.50	
Carpenter Tender	12.51	.27
Cement Mason/Concrete Finisher Tender	11.04	
Common or General	10.40	.01
Guardrail/Fence Installer	13.22	
Pipelayer	12.43	
Traffic Signal/Lighting Installer	15.65	.24
<b>PAINTER</b>		
Bridge	23.77	
<b>POWER EQUIPMENT OPERATORS</b>		
Asphalt Broom Tractor	10.00	
Bulldozer Fine	16.13	
Bulldozer Rough	14.36	
Concrete Grinder/Groover	17.92	
Crane Boom Trucks	18.19	
Crane Other	19.83	
Crane Rough/All-Terrain	19.10	
Drill Operator Rock	14.28	
Drill Operator Structure	20.89	
Excavator Fine	16.95	
Excavator Rough	13.63	
Grader/Blade Fine	19.84	
Grader/Blade Rough	15.47	
Loader 2 Cubic Yards or Less	13.31	
Loader Greater Than 2 Cubic Yards	16.19	
Material Transfer Vehicle (Shuttle Buggy)	15.44	
Mechanic	17.51	
Milling Machine	15.22	
Off-Road Hauler/Water Tanker	11.83	
Oiler/Greaser	14.16	
Pavement Marking Equipment	12.05	
Paver Asphalt	15.97	
Paver Concrete	18.20	
Roller Asphalt Breakdown	12.79	
Roller Asphalt Finish	13.76	
Roller Other	12.08	
Scraper Finish	12.65	
Scraper Rough	11.50	
Slip Form Machine	19.60	
Tack Truck/Distributor Operator	14.82	
<b>TRUCK DRIVER</b>		
GVWR of 26,000 Lbs or Less	11.45	
GVWR of 26,000 Lbs or Greater	13.57	.03

Welders – Receive rate prescribed for craft performing operation to which welding is incidental.

Note: Executive Order (EO) 13706, Establishing Paid Sick Leave for Federal Contractors applies to all contracts subject to the Davis-Bacon Act for which the contract is awarded (and any solicitation was issued) on or after January 1, 2017. If this contract is covered by the EO, the contractor must provide employees with 1 hour of paid sick leave for every 30 hours they work, up to 56 hours of paid sick leave each year. Employees must be permitted to use paid sick leave for their own illness, injury or other health-related needs, including preventive care; to assist a

family member (or person who is like family to the employee) who is ill, injured, or has other health-related needs, including preventive care; or for reasons resulting from, or to assist a family member (or person who is like family to the employee) who is a victim of, domestic violence, sexual assault, or stalking. Additional information on contractor requirements and worker protections under the EO is available at [www.dol.gov/whd/govcontracts](http://www.dol.gov/whd/govcontracts).

Unlisted classifications needed for work not included within the scope of the classifications listed may be added after award only as provided in the labor standards contract clauses (29 CFR 5.5(a)(1)(ii)).

The body of each wage determination lists the classification and wage rates that have been found to be prevailing for the cited type(s) of construction in the area covered by the wage determination. The classifications are listed in alphabetical order of "identifiers" that indicate whether the particular rate is a union rate (current union negotiated rate for local), a survey rate (weighted average rate) or a union average rate (weighted union average rate).

#### Union Rate Identifiers

A four letter classification abbreviation identifier enclosed in dotted lines beginning with characters other than "SU" or "UAVG" denotes that the union classification and rate were prevailing for that classification in the survey. Example: PLUM0198-005 07/01/2014. PLUM is an abbreviation identifier of the union which prevailed in the survey for this classification, which in this example would be Plumbers. 0198 indicates the local union number or district council number where applicable, i.e., Plumbers Local 0198. The next number, 005 in the example, is an internal number used in processing the wage determination. 07/01/2014 is the effective date of the most current negotiated rate, which in this example is July 1, 2014.

Union prevailing wage rates are updated to reflect all rate changes in the collective bargaining agreement (CBA) governing this classification and rate.

#### Survey Rate Identifiers

Classifications listed under the "SU" identifier indicate that no one rate prevailed for this classification in the survey and the published rate is derived by computing a weighted average rate based on all the rates reported in the survey for that classification. As this weighted average rate includes all rates reported in the survey, it may include both union and non-union rates. Example: SULA2012-007 5/13/2014. SU indicates the rates are survey rates based on a weighted average calculation of rates and are not majority rates. LA indicates the State of Louisiana. 2012 is the year of survey on which these classifications and rates are based. The next number, 007 in the example, is an internal number used in producing the wage determination. 5/13/2014 indicates the survey completion date for the classifications and rates under that identifier.

Survey wage rates are not updated and remain in effect until a new survey is conducted.

#### Union Average Rate Identifiers

Classification(s) listed under the UAVG identifier indicate that no single majority rate prevailed for those classifications; however, 100% of the data reported for the classifications was union data. EXAMPLE: UAVG-OH-0010 08/29/2014. UAVG indicates that the rate is a weighted union average rate. OH indicates the state. The next number, 0010 in the example, is an internal number



used in producing the wage determination. 08/29/2014 indicates the survey completion date for the classifications and rates under that identifier.

A UAVG rate will be updated once a year, usually in January of each year, to reflect a weighted average of the current negotiated/CBA rate of the union locals from which the rate is based.

#### WAGE DETERMINATION APPEALS PROCESS

1.) Has there been an initial decision in the matter? This can be:

- \* an existing published wage determination
- \* a survey underlying a wage determination
- \* a Wage and Hour Division letter setting forth a position on a wage determination matter
- \* a conformance (additional classification and rate) ruling

On survey related matters, initial contact, including requests for summaries of surveys, should be with the Wage and Hour Regional Office for the area in which the survey was conducted because those Regional Offices have responsibility for the Davis-Bacon survey program. If the response from this initial contact is not satisfactory, then the process described in 2.) and 3.) should be followed.

With regard to any other matter not yet ripe for the formal process described here, initial contact should be with the Branch of Construction Wage Determinations. Write to:

Branch of Construction Wage Determinations  
Wage and Hour Division  
U. S. Department of Labor  
200 Constitution Avenue, N.W.  
Washington, D.C. 20210

2.) If the answer to the question in 1.) is yes, then an interested party (those affected by the action) can request review and reconsideration from the Wage and Hour Administrator (See 29 CFR Part 1.8 and 29 CFR Part 7). Write to:

Wage and Hour Administrator  
U.S. Department of Labor  
200 Constitution Avenue, N.W.  
Washington, D.C. 20210

The request should be accompanied by a full statement of the interested party's position and by any information (wage payment data, project description, area practice material, etc.) that the requestor considers relevant to the issue.

3.) If the decision of the Administrator is not favorable, an interested party may appeal directly to the Administrative Review Board (formerly the Wage Appeals Board). Write to:

Administrative Review Board  
U.S. Department of Labor  
200 Constitution Avenue, N.W.  
Washington, D.C. 20210

4.) All decisions by the Administrative Review Board are final.

END OF GENERAL DECISION

**WORK ZONE TRAFFIC CONTROL  
Project Special Provisions  
Table of Contents**

<b>Special Provision</b>	<b>Page</b>
Work Zone Traffic Control for Interstate/Freeway Resurfacing Projects	TC-2
Work Zone Presence Lighting	TC-12
Sequential Flashing Warning Lights	TC-15
Interstate/Freeway Maximum Lane Closure Length	TC-17



DocuSigned by:  
*Tim Kirk*  
4A6AB92EF1FC462...

## WORK ZONE TRAFFIC CONTROL FOR INTERSTATE/FREEWAY RESURFACING PROJECTS

### **GENERAL REQUIREMENTS**

This Provision is intended for Interstate/Freeway Resurfacing projects that are performed at night. In the event, the Day and time Restrictions allow for daytime work activities the Work zone Presence Lighting and Sequential Flashing Lights are to be omitted. However, the Digital Speed Limit Signs will be required as described below.

Maintain traffic in accordance with Divisions 10, 11 and 12 of the *2018 Standard Specifications* and the following provisions:

Install Work Zone Advance Warning Signs in accordance with the attached drawing prior to beginning any other work.

When personnel and/or equipment are working on the shoulder adjacent to a divided facility and within 10 feet of an open travel lane, close the nearest open travel lane using Standard Drawing No. 1101.02 of the *2018 Roadway Standard Drawings*.

When personnel and/or equipment are working within a lane of travel of a divided facility, close the lane using Standard Drawing No. 1101.02 of the *2018 Roadway Standard Drawings* or as directed by the Engineer. Conduct the work so that all personnel and/or equipment remain within the closed travel lane. Perform work only when weather and visibility conditions allow safe operations as directed by the Engineer.

#### **1. Time Restrictions for Lane Closure and Road Closure Activities**

All lane closure and road closure activities shall be performed in compliance with the Day and Time restrictions listed and defined in this Contract.

Any activities performed outside of these requirements will be subject to the Liquidated Damages unless approved by the Engineer prior to beginning the activity.

The Contractor may place/pre-stage all required signs and traffic control devices necessary for lane closures prior to the closure time as approved by the Engineer. However, flashing arrow boards and changeable message signs shall not indicate lane closure information until 30 minutes or less prior to the installation of the lane closure. Typical pre-staging times are 1 hour for a single lane closure and 2 hours for double and triple lane closures. The travel lane(s) are to be closed at the prescribed times defined in this Contract.

For removal, the lane(s) must be reopened in compliance with the times defined in this Contract. It is acceptable to remove the signs and traffic control devices from the shoulder/staging area after the lane(s) are reopened to traffic.

#### **2. Work Zone Speed Limits and Digital Speed Limit Signs (DSLS)**

All speed limits are to be ordinated by the State Traffic Engineer in order to have a lawfully enforceable speed limit; therefore, no speed limit messages/signs shall be installed prior to receiving a signed ordinance. NCDOT has sole authority of the speed limits displayed within the work zone.

The Regional Traffic Engineering Office and the Division Construction Engineer in coordination with the Work Zone Traffic Control Section will provide all Work Zone Speed Limit recommendations based on activities and conditions.

# TC-3

C204116

Mecklenburg County

When lane closures are in effect and if ordinated by the State Traffic Engineer, implement a Work Zone “Variable” Speed Limit Reduction as stated in the ordinance and in accordance with the attached Provision and drawing.

Use Digital Speed Limit Signs (DSLS) to display the work zone speed limit as shown in the attached drawing. The Speed Limit shall be continuously displayed on the digital speed limit signs. (See Attached Provision.)

The Contractor will be responsible for coordinating with the Engineer when the Work Zone Speed Limits are to be changed and will have to seek approval by the Engineer before the Speed Limit is changed.

When the variable speed limit reductions are in effect, cover any existing speed limit signs located within the active work area that conflict with the variable speed limit reduction.

The speed limit shall be returned to the existing speed limit when the lane closure is removed and traffic is returned to the existing pattern.

### **3. Work Zone Presence Lighting and Sequential Flashing Warning Lights**

Provide the following for nighttime work activities in accordance with attached drawing and special provisions:

A. Furnish and install Work Zone Presence Lighting to supplement the Contractor’s portable construction and equipment lighting for the purpose of alerting motorist to the existence of an active work zone and to encourage compliance with the reduced work zone speed limit. (See attached Provision.)

B. Furnish and install Sequential Flashing Warning Lights on drums used for merging tapers to assist motorist in determining which direction to merge and to decrease late lane merging. (See attached Provision.)

### **4. Law Enforcement**

Use off duty, uniformed Law Enforcement Officers and official Law Enforcement vehicles, equipped with blue lights, to direct/control/stop traffic or to manage work zone speeds as required by the plans or by the Engineer.

Law Enforcement vehicles shall not be parked within the buffer space.

The Contractor shall provide 2 Law Enforcement Officers for the mainline during lane closure operations and 2 additional Law Enforcement Officers for ramp/loop closures when both operations occur simultaneously.

Use Law Enforcement Officers to assist in the shadowing of workers during the installation and during the removal of lane closures.

### **TEMPORARY TRAFFIC CONTROL (TTC)**

Refer to Standard Drawing No. 1101.02, 1101.11, 1110.01, 1110.02, 1115.01, 1130.01, 1135.01, 1165.01, and 1180.01 of the *2018 Roadway Standard Drawings* when closing a lane of travel in a stationary work zone for items such as milling, paving, diamond grinding concrete pavements, minor bridge and approach slab rehabilitation.

Drums are recommended for all lane closure operations occurring at night. However, if skinny drums are used at night, they shall be placed every 20’ in the tangent sections of lane closure operations. Skinny drums shall not be used for upstream tapers.

## TC-4

C204116

Mecklenburg County

When covering work zone signs, use an opaque material that prevents reading of the sign at night by a driver using high beam headlights. Use material, which does not damage the sign sheeting. Refer to Standard Drawing No. 1101.02, Sheets 9 and 10 of the 2018 Roadway Standard Drawings for diamond grinding, milling and/or paving of ramps unless otherwise approved to be closed by the Engineer. If approved, see attached drawing for typical placement of devices and signing for the detour route. All items shall be compensated for based on the unit bid price for the respective item.

Refer to Standard Drawing No. 1101.03, sheet 7 of the 2018 Roadway Standard Drawings for a closure of the interstate/freeway with traffic detoured via interchange ramps for items such as minor bridge and approach slab rehabilitation. Use Flaggers or Law Enforcement to direct traffic at ramp terminals as directed by the Engineer.

Refer to Standard Drawing No. 1101.02, sheet 12 or 13 of the *2018 Roadway Standard Drawings* for utilizing a Moving Operation for such items as pavement marking and marker placement. A minimum speed of 3 mph shall be maintained at all times with no stops that narrow or close a lane of travel. If the moving operation is progressing slower than 3 mph at any time, install a lane closure. All traffic control devices for this operation is considered incidental to the pay items for Pavement Marking and Markers.

### **TRAFFIC OPERATIONS**

#### **1. Project Requirements:**

Failure to comply with the following requirements will result in a suspension of all other operations:

- A. Before working on ANY MAP, the Contractor shall submit a written construction sequence for traffic control and construction lighting for ALL MAPS to the Engineer at the first pre-construction meeting and the sequence must be approved before closing a lane of traffic. The Contractor and Engineer will coordinate with the State Work Zone Engineer at 919-814-4937 for additional traffic control guidance, as necessary.
- B. The maximum "Active Work Area" is a distance of 5 miles. It is defined as the maximum allowable distance for Resurfacing Operations taking place in a single work period. Therefore, the maximum length of lane closure is 5 miles. However, approval by the Engineer is required before closing more than 2 miles of Interstate to ensure the Contractor has the equipment and labor force to actively pursue the work.
- C. Notify the Engineer 15 consecutive calendar days before resurfacing a bridge or its approaches. Patch and make repairs to bridge surface and its approaches before resurfacing occurs. Coordinate all operations on the bridge and its approaches with the Engineer.
- D. Notify the Engineer 48 hours before resurfacing the areas of existing pavement that require patching. Patch these areas before resurfacing occurs. Allow full depth asphalt patching to cool to the point of supporting traffic without displacement or rutting before reopening closed lane. Coordinate the resurfacing operations of the patched areas with the Engineer.

# TC-5

C204116

Mecklenburg County

- E. Notify the Engineer 48 hours before milling or resurfacing will interfere with the existing Signal Loops. Loops may need to be placed in milled surface before resurfacing occurs. Coordinate all signal loop operations with the Engineer.
- F. Obtain written approval of the Engineer before working in more than one location or setting up additional lane closures.
- G. The Contractor on this and any adjacent projects, or subcontractors working within this project shall coordinate lane closure location, type, and direction with the Engineer to best maintain lane continuity through the limits of this and adjacent projects.
- H. Operate equipment and conduct operations in the same direction as the flow of traffic. Maintain vehicular access in accordance with Article 1101-05 of the *2018 Standard Specifications*.
- I. Provide appropriate construction lighting in accordance with Section 1413 of the *2018 Standard Specifications*.
- J. Contractor shall diamond grind, mill and pave lanes in an order such that water shall not accumulate.

## **2. Paving Lift Requirements and Time Limitations:**

**Failure to comply with the following requirements will result in a suspension of all other operations until all lanes of traffic are brought to the same station and elevation:**

### Paving Overlays and Lifts up to 3”

- A. For surface course paving lifts of 2.0” or less, the Contractor shall conduct his paving operations such that the following conditions are met.  
Once paving begins in any lane, the Contractor will be permitted to pave as far as the work operations allow (up to 5 miles) for the initial paving period. In the next days’ paving operation, not to exceed 72 hours, bring the adjacent lane to the same station and elevation. At the end of the work day, any uneven lane conditions shall be signed with an “UNEVEN PAVEMENT/NEXT XX MILES” on the portable changeable message signs and portable “UNEVEN PAVEMENT” signs (dual mounted) 1,000’ in advance of the uneven pavement and every ½ miles thereafter along the uneven portion of roadway. Once mitigated, all portable “UNEVEN PAVEMENT” signs shall be removed.  
For Open Graded Surface Mixes, “UNEVEN PAVEMENT” signs are not required.
- B. For 3” surface course mixes, place in two paving lifts of 1 ½” each unless directed otherwise by the Engineer. Conditions for uneven travel lanes same as described above.

### Paving Lifts Greater than 3”

For all other paving lifts greater than 3”, bring all newly resurfaced lanes to the same station and elevation by the end of each work day unless the Contractor utilizes the notched wedge paving methods as described below:

## TC-6

C204116

Mecklenburg County

- A. Any paving lift greater than 3" shall be mitigated by having an approved wedge apparatus on the paver that shapes the edge 1" vertically and the remaining at a maximum slope steepness of 2:1. The maximum paving lift allowed to use this method is 3".
- B. At the end of the work day, the Contractor shall place portable "UNEVEN PAVEMENT" signs in advance of the uneven pavement and spaced every ½ mile along the section of uneven pavement. Once mitigated, all portable "UNEVEN PAVEMENT" signs shall be removed.
- C. In the next day's paving operation and not to exceed 72 hours, the Contractor shall bring up the adjacent lane to the same station and elevation before any further paving takes place on the project.

### Milling Operations (Does Not Apply to Fine Milling)

Conduct milling operations so that any milled pavement is paved back by the end of each work day.

A milled/grooved surface shall not be re-opened to traffic except in cases where inclement weather or mechanical failure prevents the paving back of the lane by the end of the work day.

If milled areas are not paved back within the same work period due to inclement weather or mechanical failure, the Contractor is to furnish and install portable signs to warn drivers of the conditions. The signs include "Grooved Pavement" (W8-15) w/ Motorcycle Plaque mounted below, and "Uneven Lanes" (W8-11). These are to be dual indicated where lateral clearance can be obtained within the median areas. Install the "Grooved Pavement" (W8-15) w/ Motorcycle Plaque 1500' in advance of the milled area. Install the "Uneven Lanes" (W8-11) 500' in advance of the milled area. Alternate these signs every ½ mile. Once mitigated, all portable signs are to be removed.

Slope the pavement at the beginning and ending of the daily milling operation as directed by the Engineer. Sweep and remove all milled material from the roadway as soon as the daily milling operation is completed. Remove any existing pavement adjacent to the milled area that has been damaged and replace with patch material as directed by the Engineer.

### Fine Milling / Microsurfacing Operations (Depths less than 1")

For fine milling operations less than 1", paving is not required in the same work period. The paving of the fine milled area is to be conducted within the next work period and not to exceed 72 hours. No advance warning signs are needed for the conditions. However, pavement markings are required by the end of each work day.

### **3. Temporary Pavement Markings:**

Review and record the existing pavement markings and markers before obliteration. Re-establish the new pavement markings and markers using the record of existing markings in conjunction with the *2018 Roadway Standard Drawings* unless otherwise directed by the Engineer. Submit the record of the existing pavement markings seven calendar days before the obliteration of any pavement markings.

Obliterated pavement markings shall be replaced by the end of each workday's operation. Interim paint may be used to comply with time limitations if final pavement markings cannot be placed except for milled surfaces or diamond ground surfaces. Final markings shall be placed within 30

days in accordance with Section 1205-4 and Section 1205-5. For milled surfaces, temporary pavement markings shall be used in accordance with Section 1205-8(C). There will be no direct payment for interim paint. Temporary paint will be paid for at the contract unit price.

For concrete surfaces that have been diamond ground as a surface treatment, 4" temporary paint shall be used in accordance with Section 1205-8(C). Upon completion of all diamond grinding operations, 4" line removal shall be used to remove 100% of the 4" temporary paint on the final concrete surface by grinding method only. Use an acceptable method to grind ridges smooth only where pavement markings will be installed prior to placing final pavement marking material. This method shall also be used in the area of the black contrast for surface preparation. Payment for line removal will be made in accordance with Section 1205-10.

For project winterization, install temporary paint markings in accordance with Section 1205-8(C) of the 2018 Standard Specifications. Use 4" lane, edge, and center lines and 8" gore lines. Compensation for this work shall be made in accordance with Section 1205-10 except that no payment will be made if paving is completed more than 30 days before the written notification by the Department that winterization is required.

#### **4. Work Zone Signing:**

##### **A. Description**

Install advance/general warning work zone signs according to the attached drawings prior to beginning work.

For paving overlays of 3" or greater that create a drop-off adjacent to the median shoulder, install "LOW/SOFT SHOULDER" (SP 13107) signs on the median shoulder. Place initially at the construction limits, and then space 1 mile thereafter. No signing required for the outside shoulder.

Install and maintain signing in accordance with the Divisions 11 and 12 of the *2018 Standard Specifications*.

##### **B. Installation**

All stationary Advance/General warning work zone signs require notification to existing Utility owners per Article 105-8 of the 2018 Standard Specifications and Special Provision SP1 G115 within 3 to 12 full working days prior to installation.

Install all Advance/General warning work zone signs before beginning work on a particular map. If signs are installed more than seven (7) calendar days prior to the beginning of work on a particular map, cover the signs until the work begins. Install each work zone Advance/General warning sign separately and not on the same post or stand with any other sign except where an advisory speed plate or directional arrow is used.

All sign locations to be verified by the Engineer prior to installation. Once the signs have been installed and accepted, any sign relocations requested by the Department will be compensated in accordance with Article 104-7. Any additional signs other than the ones required in this provision or attached drawings will be compensated in accordance with Article 104-7.

If there is a period of construction inactivity longer than 14 calendar days, remove or cover advance/general warning work zone signs. Uncover advance/general warning work zone signs no more than 7 calendar days before work resumes.



All other operations may be suspended upon failure to comply with the above requirements. Such suspended operations would not be resumed until the above requirements are fulfilled.

### **C. Sign Removal**

Once Maps on the Project are substantially completed, it is acceptable to remove the Stationary Work Zone Signs on those Maps in lieu of waiting until all of the Maps are completed on the Project. A Map is substantially complete when the resurfacing operations are completed and the shoulders are brought up to the same elevation as the proposed pavement and when temporary pavement markings (paint) are installed along the centerline and edge lines as well as the ramps and loops. The final pavement markings (Thermoplastic or Polyurea) and/or markers do not have to be installed for the Map to be considered substantially complete. Final Pavement Markings/Markers are installed with portable signing and changeable message signs according to Roadway Standard Drawing 1101.02, sheet 13. Any remaining punch list items requiring traffic control are to be completed with portable work zone signing with compensation covered in the Contract Unit price for price for the required Traffic Control items.

**Stationary Work Zone Sign removal is a condition of final project acceptance.**

### **D. Lane Closure Work Zone Signs**

Install any required lane closure signing needed during the life of the project in accordance with the Standard Drawing No. 1101.02, 1101.11 and 1110.02 of the *2018 Roadway Standard Drawings*.

## **MEASUREMENT AND PAYMENT**

Stationary Work Zone Signs will be measured and paid as the actual number of square feet satisfactorily installed at each location and accepted by the Engineer.

Refer to the respective Sections of Division 11 and 12 of the 2018 Standard Specifications or the attached Special Provisions for the satisfactory installation and removal of lane closures and temporary pavement markings and markers.

Measurement for "Lane Closures" is the actual number of stationary lane closures satisfactorily installed for paving and all other required operations as shown in Roadway Standard Drawing 1101.02, sheets 4, 5, 6, 8, 9 & 10. All labor, traffic control devices, and signing for lane closures as shown in these Roadway Standard Drawings are paid under this item.

Lane closures will be measured and paid at the Contractor's unit price for Lane Closure on a per each basis. In the event a dual or triple lane closure is required, they will be measured individually and paid on a per each basis. The ramp lane closures shown in Roadway Standard Drawing 1101.02, sheets 9 & 10, are considered part of the mainline lane closure and will not be measured or paid separately.

Measurement for "Ramp/Loop Closures" is the actual number of total ramp/loop closures and detours satisfactorily installed for ramp/loop paving and all other required operations as shown on the Short Term Closure and Detour of Interstate/Freeway Ramps detail drawing. All labor, traffic control devices and signing required for re-routing traffic as shown on the Short Term Closure and Detour of Interstate/Freeway Ramps detail drawing are paid under this item.

# TC-9

C204116

Mecklenburg County

Ramp/Loop Closures will be measured and paid at the Contractor's unit price for Ramp/Loop Closures on a per each basis. In the event two separate ramps are closed at the same time, they will be measured individually and paid on a per each basis.

Measurement and payment for paint pavement marking lines, paint pavement marking symbols, removal of pavement marking lines will be according to Section 1250-10.

Measurement and payment for law enforcement will be made and paid as the actual number of hours each Law Enforcement Officer provides during the life of the project as approved by the Engineer.

Digital Speed Limit Signs, Sequential Flashing Warning Lights, and Work Zone Presence Lighting are paid separately.

Payment will be made under:

<b>Pay Item</b>	<b>Pay Unit</b>
Work Zone Signs (Stationary)	SF
Lane Closure	EA
Ramp/Loop Closure	EA
Paint Pavement Marking Lines ( __”)	LF
Paint Pavement Marking Symbols	EA
Removal of Pavement Marking Lines ( __”)	LF
Law Enforcement	HR

STATIONARY ADVANCE WARNING SIGNS FOR INTERSTATE / FREEWAY RESURFACING PROJECTS

DIVIDED MEDIANS WITH WIDTHS 46' OR GREATER

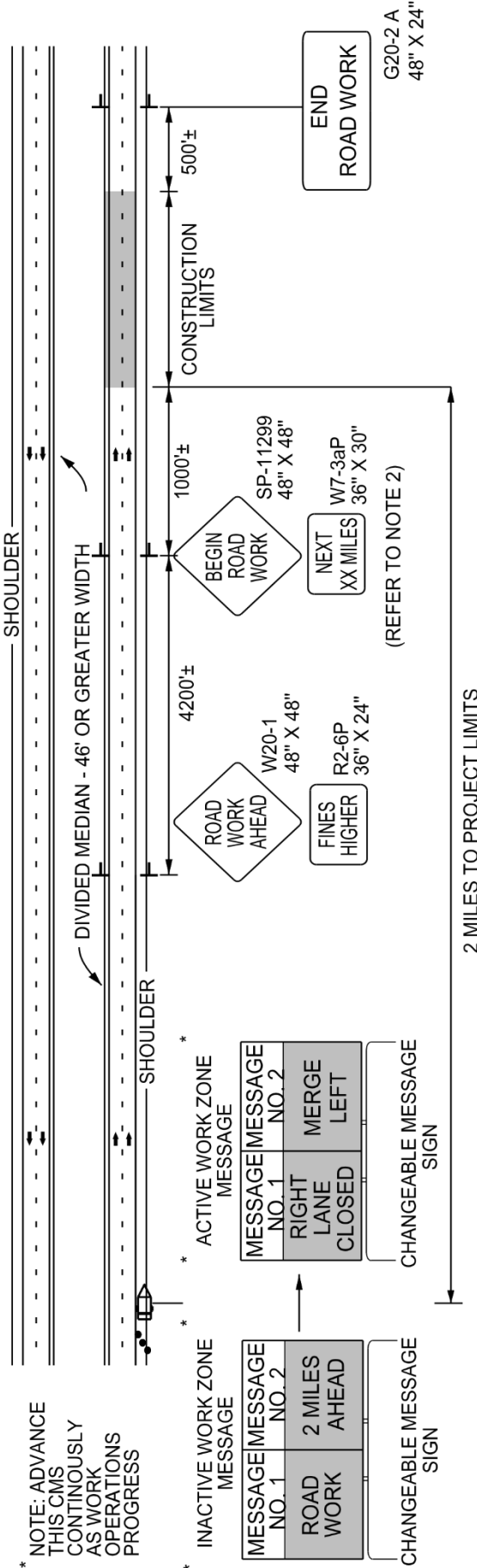

DIVIDED MEDIANS WITH WIDTHS LESS THAN 46' OR WITH PERMANENT MEDIAN BARRIER

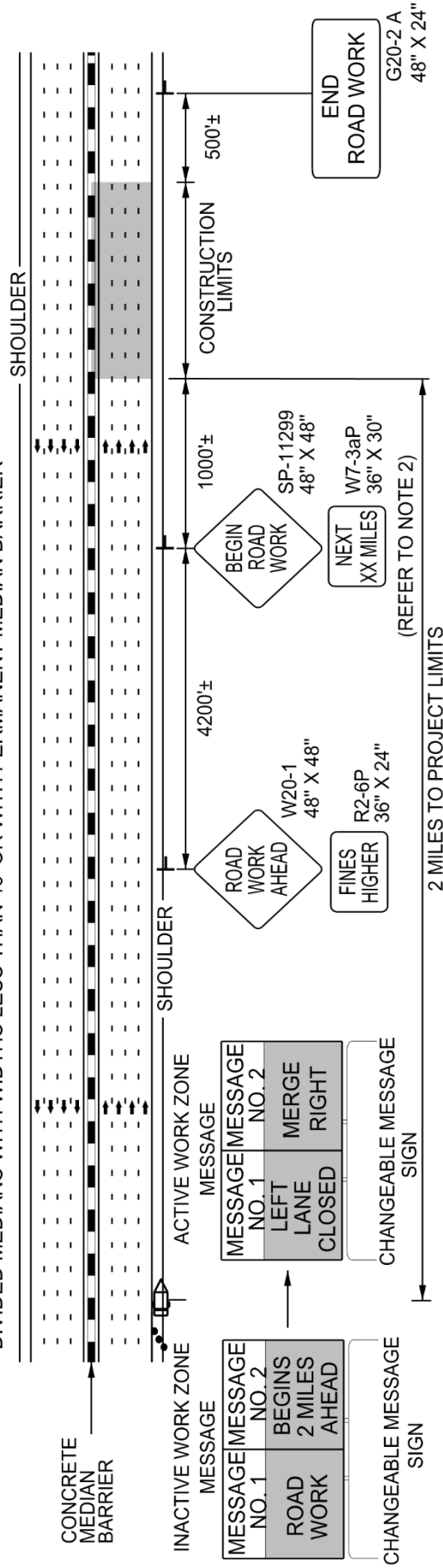

- NOTES**
1. THIS DRAWING IS TO BE USED IN CONJUNCTION WITH THE WORK ZONE VARIABLE SPEED LIMIT USING DIGITAL SPEED LIMIT SIGNS FOR INTERSTATE/FREEWAY RESURFACING PROJECTS DETAIL.
  2. FOR SIGN W7-3aP, ROUND TO THE NEAREST MILE.
  3. FOR ENTRANCE AND EXIT RAMP, REFER TO RSD 1101.01, SHEET 1, DETAIL B & C.
  4. FOR ADDITIONAL NOTES, REFER TO RSD 1101.01, SHEET 1.

**LEGEND**

DIRECTION OF TRAFFIC FLOW  
 TRAFFIC DRUM  
 CHANGEABLE MESSAGE SIGN (CMS)  
 STATIONARY SIGN

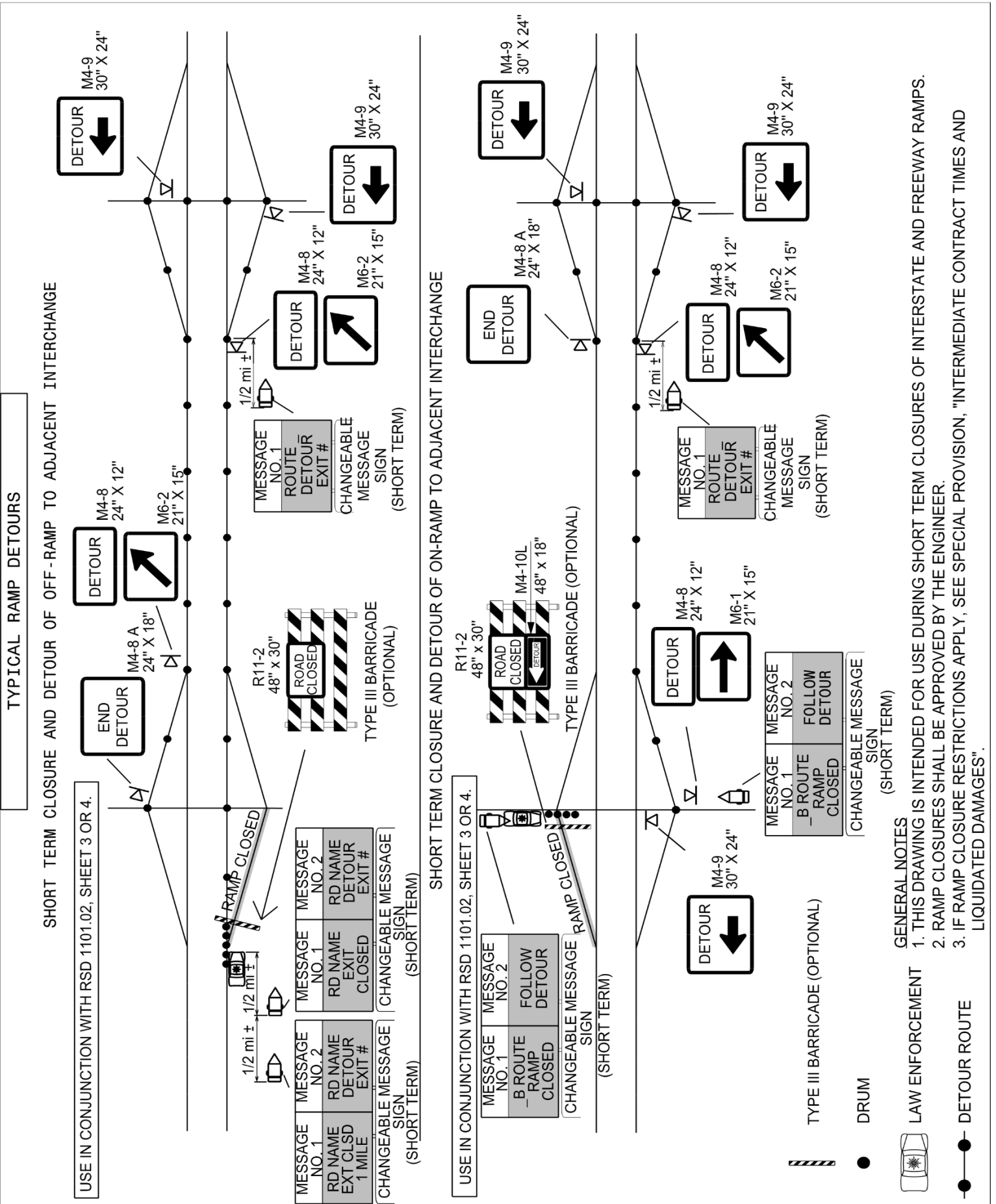

# TC-12

C204116

Mecklenburg County

## **WORK ZONE PRESENCE LIGHTING:**

(10/08/16)

### **Description**

Furnish and install Work Zone Presence Lighting to supplement the Contractor's task (Portable Construction Lighting) and equipment lighting during nightly work activities on high speed (greater than 55 MPH) facilities and/or facilities that have significant traffic volumes and impacts. The purpose of this additional lighting is to alert the motorist to the existence of an active work zone and to assist in compliance of the work zone speed limit by providing lighting in advance and throughout the length of the lane closure.

### **Materials**

Anti-glare lighting systems are required. They are in addition to the Contractors' portable construction lighting. These devices shall be installed in accordance with the attached drawing and Manufacturer's recommendations.

All Work Zone Presence Lighting shall be supplied with a power source to provide the light output as described in the chart below.

All Work Zone Presence Lighting equipment shall be on the NCDOT Work Zone Traffic Control Approved Products List.

### **Construction Methods**

Work Zone Presence Lighting is to provide lighting to areas of the lane closure where there is an absence of the Contractor's task lighting. If the Contractor provides sufficient task lighting to meet the luminance requirements of Section 1413-3 of the 2018 NCDOT Standard Specifications for the full length of the lane closure, or if there is sufficient existing overhead lighting, Work Zone Presence Lighting may be eliminated as directed by the Engineer. Work Zone Presence Lighting shall not conflict with the Contractor's lighting or work operations.

Each light unit shall be capable of providing a minimum of 50,000 lumens illuminating a minimum area of approximately 20,000 square feet. The light shall be capable of being elevated to a height of 14 feet above the pavement. The lighting units shall be installed inside the full length of the lane closure as shown on the attached drawing and spaced according to the chart.

### **SPACING CHART**

<b>Light Output (Lumens)</b>	<b>Minimum Lighted Fixture Area (Square Feet)</b>	<b>Maximum Spacing (Feet)</b>	<b>Light Units (Per Mile)</b>
50,000 to 65,000	5.5	750'	6
66,000 to 80,000	5.5	1,000'	5

# TC-13

C204116

Mecklenburg County

81,000 to 100,000	36	1,250	4
-------------------	----	-------	---

Each light unit shall be installed along with the lane closure traffic control devices and moved as necessary to allow for efficient paving operations to take place as well as to not interfere with the Contractor's ability to light the work area.

Whenever possible, each light unit shall be placed on the 10 foot paved shoulder according to the above spacing based on the amount of light output for each unit. Each light unit support structure or mounting stand shall have the capability of being leveled.

## Measurement and Payment

The measurement for the Work Zone Presence Lighting is made according to the number of lighting units required per the spacing requirements and the attached drawing. Payment will be made for the maximum number of Work Zone Presence Lighting units satisfactorily installed and properly functioning at any one time during the life of the project. No measurement or separate payment will be made for power generators.

This includes all materials and labor to install, maintain and remove all the Work Zone Presence Lighting Units from the lane closure/s on a nightly basis.

## Pay Item

Work Zone Presence Lighting

## Pay Unit

Each

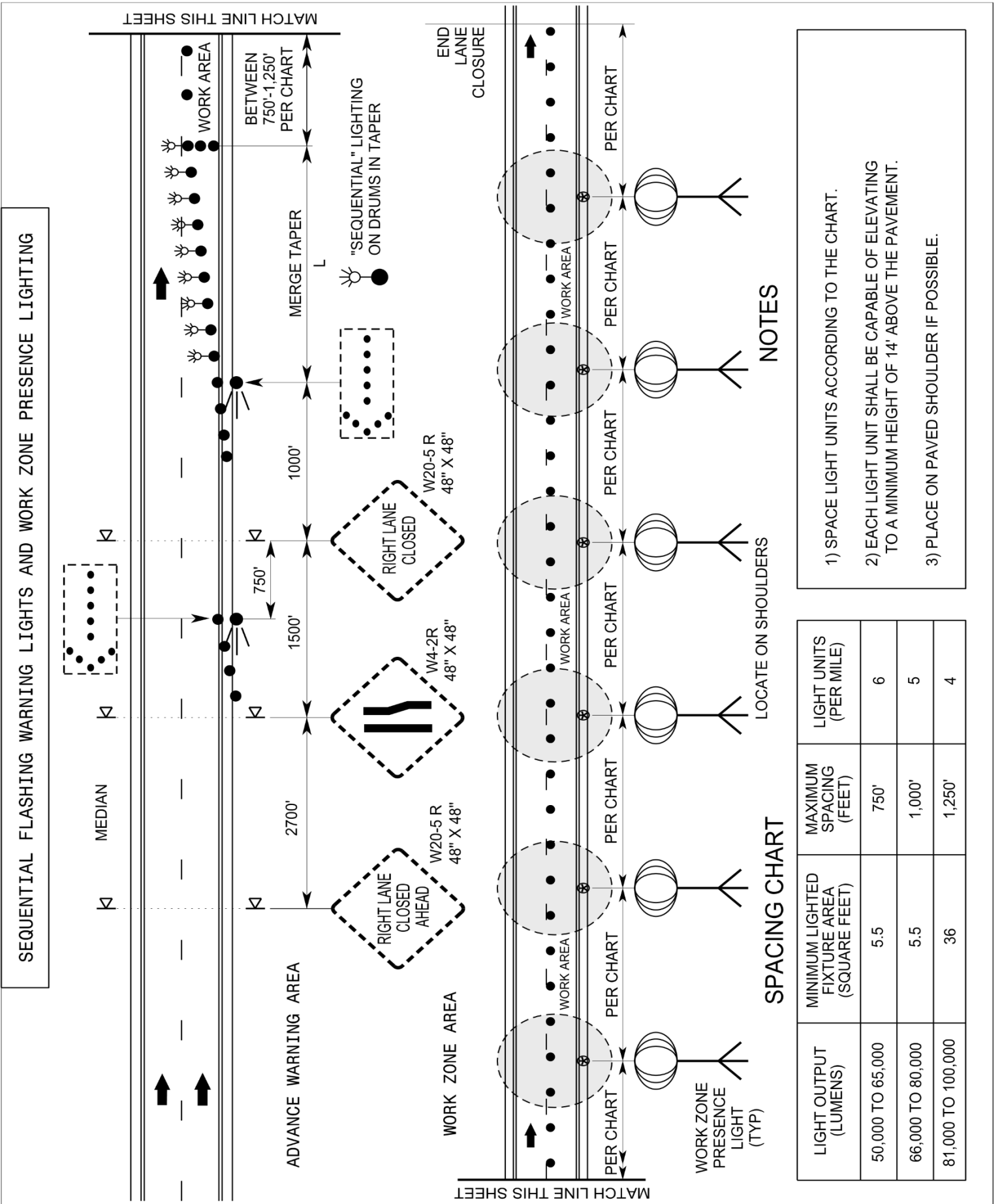

# TC-15

C204116

Mecklenburg County

## **SEQUENTIAL FLASHING WARNING LIGHTS:**

(10/08/2016)

### **Description**

Furnish and install Sequential Flashing Warning Lights on drums used for merging tapers during nightly work activities on interstates and freeways with speed limits greater than 55 MPH and or facilities that have significant traffic volumes.

The purpose of these lights is to assist the motorist in determining which direction to merge when approaching a lane closure. It's also designed to reduce the number of late merges resulting in devices being struck and having to be reset to maintain positive guidance at the merge point. The successive flashing of the lights shall occur from the upstream end of the merging taper to the downstream end of the merging taper in order to identify the desired vehicle path.

### **Materials**

The Sequential Flashing Warning Lights shall meet all of the requirements for warning lights within the current edition of the Manual of Uniform Traffic Control Devices (MUTCD).

Each light unit shall be capable of operating fully and continuously for a minimum of 200 hours when equipped with a standard battery set.

Each light in the sequence shall be flashed at a rate of not less than 55 times per minute and not more than 75 times per minute. The flash rate and flash duration shall be consistent throughout the sequence.

Supply a Type 3 Certification (Independent Test Lab results) documenting all actual test results for the specified parameters contained in the Institute of Transportation Engineer's (ITE's) *Purchase Specification for Flashing and Steady Burn Warning Lights*. The laboratory shall also identify all manufacturer codes and part numbers for the incandescent lamp or LED clusters, lenses, battery, and circuitry, and the total width of the light with the battery in place. The complete assembly shall be certified as crashworthy when firmly affixed to the channelizing device.

All Sequential Flashing Warning Lights shall be on the NCDOT Work Zone Traffic Control Approved Products List.

### **Construction Methods**

Sequential Flashing Warning Lights are to be used for night time lane closures.

These lights shall flash sequentially beginning with the first light and continuing until the final light.

The Sequential Flashing Warning Lights shall automatically flash in sequence when placed on the drums that form the merging taper.



# TC-16

C204116

Mecklenburg County

The number of lights used in the drum taper shall equal the number of drums used in the taper.

Drums are the only channelizing device allowed to mount sequential flashing warning lights.

The Sequential Flashing Warning Lights shall be weather independent and visual obstructions shall not interfere with the operation of the lights.

The Sequential Flashing Warning Lights shall automatically sequence when placed in line in an open area with a distance between lights of 10 to 100 feet. A 10 foot stagger in the line of lights shall have no adverse effect on the operation of the lights.

If one light fails, the flashing sequence shall continue. If more than 1 light fails, all of the lights are to be automatically turned to the "off" mode. Non-sequential flashing is prohibited.

When lane closures are not in effect, the Sequential Flashing Warning Lights shall be deactivated.

## Measurement and Payment

Sequential Flashing Warning Lights will be measured and paid as the maximum number of sequential flashing warning lights satisfactorily installed and properly functioning at any one time during the life of the project.

This includes all materials and labor to install, maintain and remove all the Sequential Flashing Warning Lights.

### Pay Item

Sequential Flashing Warning Lights

### Pay Unit

Each

# TC-17

C204116

Mecklenburg County

## **INTERSTATE/FREEWAY MAXIMUM LANE CLOSURE LENGTH:**

(03/20/17)

The maximum lane closure length on this project is 2 miles. This supersedes the allowable 5 mile maximum lane closure length located in Traffic Operations Section (1B) of the Interstate/Freeway Resurfacing Provision.

All quantities for required traffic control devices, digital speed limit signs, work zone presence lighting and law enforcement hours as well as paving production rates are to be based on this requirement.

# EC-1

## **WATTLE:**

(10-19-10) (Rev. 1-17-12)

1060,1630,1631

T1

### **Description**

Wattles are tubular products consisting of excelsior fibers encased in synthetic netting. Wattles are used on slopes or channels to intercept runoff and act as a velocity break. Wattles are to be placed at locations shown on the plans or as directed. Installation shall follow the detail provided in the plans and as directed. Work includes furnishing materials, installation of wattles, matting installation, and removing wattles.

### **Materials**

Wattle shall meet the following specifications:

100% Curled Wood(Excelsior) Fibers	
Minimum Diameter	12 in.
Minimum Density	2.5 lb/ft <sup>3</sup> +/- 10%
Net Material	Synthetic
Net Openings	1 in. x 1 in.
Net Configuration	Totally Encased
Minimum Weight	20 lb. +/- 10% per 10 ft. length

Stakes shall be used as anchors.

Provide hardwood stakes a minimum of 2 feet long with a 2 inch x 2 inch nominal square cross section. One end of the stake must be sharpened or beveled to facilitate driving down into the underlying soil.

Matting shall meet the requirements of Article 1060-8 of the *2018 Standard Specifications*, or shall meet specifications provided elsewhere in this contract.

Provide staples made of 0.125 inch diameter new steel wire formed into a *u* shape not less than 12 inches in length with a throat of 1 inch in width.

### **Construction Methods**

Wattles shall be secured to the soil by wire staples approximately every 1 linear foot and at the end of each section of wattle. A minimum of 4 stakes shall be installed on the downstream side of the wattle with a maximum spacing of 2 linear feet along the wattle, and according to the detail. Install a minimum of 2 stakes on the upstream side of the wattle according to the detail provided in the plans. Stakes shall be driven into the ground a minimum of 10 inches with no more than 2 inches projecting from the top of the wattle. Drive stakes at an angle according to the detail provided in the plans.

## EC-2

Only install wattle(s) to a height in ditch so flow will not wash around wattle and scour ditch slopes and according to the detail provided in the plans and as directed. Overlap adjoining sections of wattles a minimum of 6 inches.

Installation of matting shall be in accordance with the detail provided in the plans, and in accordance with Article 1631-3 of the *2018 Standard Specifications*, or in accordance with specifications provided elsewhere in this contract.

The Contractor shall maintain the wattles until the project is accepted or until the wattles are removed, and shall remove and dispose of silt accumulations at the wattles when so directed in accordance with the requirements of Section 1630 of the *2018 Standard Specifications*.

### **Measurement and Payment**

*Wattle* will be measured and paid for by the actual number of linear feet of wattles which are installed and accepted. Such price and payment will be full compensation for all work covered by this section, including, but not limited to, furnishing all materials, labor, equipment and incidentals necessary to install the *Wattle*.

Matting will be measured and paid for in accordance with Article 1631-4 of the *2018 Standard Specifications*, or in accordance with specifications provided elsewhere in this contract.

Payment will be made under:

#### **Pay Item**

Wattle

#### **Pay Unit**

Linear Foot

**PROJECT SPECIAL PROVISIONS  
SLAB JACKING AND JOINT REPAIR**

**TABLE OF CONTENTS**

	Page #
Slab Jacking and Undersealing/Void Filling	.....SJ-2
Hydrophobic Foam Soil Stabilization	.....SJ-3
Joint Construction, Repair and Sealing	.....SJ-7



DocuSigned by:  
  
60A6662BDE334EF... 2/1/2018

## **SLAB JACKING AND UNDERSEALING/VOID FILLING:**

### **Description**

The Contractor shall use a High Density Polyurethane Foam for slab leveling, undersealing and void filling in locations directed by the Engineer.

### **Material**

The medium used shall be blown, high density, hydrophobic polyurethane. The high density, closed cell, polyurethane system shall exhibit the following characteristics and physical properties:

<b>Density, Lbs/Ft</b> ASTM 1622	<b>Compressive Strength</b> ASTM 1621
3.0	40 psi.
3.5	50 psi.
4.0	60 psi.
6.0	110 psi.

The polyurethane foam system will have a free rise density of 3.0 – 4.2 lb/ft, with a minimum compressive strength of 40 psi. The expansion of the polyurethane foam under pressure increases the foam density above the original free rise density value. The compressive strength is a function of density of the tested material; therefore the foam produced during the lifting process will normally have a higher compressive strength than foam produced without restriction (free rise).

### **Equipment**

A list of lifting and undersealing equipment shall be submitted to the Engineer prior to commencement of the work for review. The minimum list of equipment required shall be as listed below. The listing is a minimum and shall not preclude the use of additional equipment.

- A pneumatic drill and an electric drill capable of drilling 5/8" to 3/4" dia. holes.
- A truck-mounted pumping unit capable of injecting the high density polyurethane formulation below the concrete slab or asphalt pavement. This pumping unit will be capable of controlling the rate of rise of the pavement.
- Stringlines or dial indicators may be periodically used to measure the rate of lift.

### **Construction**

For leveling and undersealing, the Contractor shall prepare concrete to be leveled by profiling the existing pavement and determining where the pavement needs to be raised. Void filling shall be in areas as indicated and as directed by the Engineer.

The Contractor shall drill a series of 5/8" holes into the pavement at 3'-6' O.C. (exact location and spacing to be determined in the field). The expanding High Density Polyurethane Foam material

# SJ-3

I-5770

MECKLENBURG COUNTY

shall be injected under the slab. The amount of rise shall be controlled by regulating the rate of High Density Polyurethane Foam material injected.

Final elevations shall be within 1/4" of the elevations proposed by profile, to the extent permitted by the structure, existing construction and site conditions. A tight string line may be used to monitor and verify elevations for slab lengths of 50ft or less. Elevations can also be verified by flooding the area to confirm that the pavement has been realigned properly. It will be the Contractor's responsibility to control these operations to make sure excessive rising of the slabs does not occur. The Contractor shall be responsible for any pavement blowouts or excessive pavement lifting which may result from the process and shall repair the damaged area to the satisfaction of the Engineer without additional cost.

The High Density Polyurethane Foam shall reach 90% of the full compressive strength in 15 minutes after injection.

Injection holes shall be sealed with a non-expansive cementitious grout once leveling is complete.

## Measurement and Payment

The polyurethane material shall be paid for by the pound and the measurement verified by the following Double Verification methods.

- A conversion from pump counters to pounds will be provided with a manufacturer's certification of the accurate conversion factor.
- A visual measurement conversion on the actual totes/barrels of pounds per inches pumped.

The quantity of material to be paid for shall be the actual quantity of High Density Polyurethane Foam used to satisfactorily complete the work. Such price and payment shall be full compensation for furnishing and injecting the material, labor, tools, equipment and all incidentals necessary to complete the work.

<b>Pay Item</b>	<b>Pay Unit</b>
Slab Leveling, Undersealing and Void Filling	Pounds

## HYDROPHOBIC FOAM SOIL STABILIZATION:

### Description

Pressure inject hydrophobic polyurethane injection resin into the soil at locations to be determined by the Engineer to permeate, stabilize weak and loose soils, and prevent water migration. The Contractor shall furnish all materials, labor, tools, and equipment to stabilize soils as specified.

**A. Quality Assurance**

Manufacturer of polyurethane material shall have been in existence for a period of not less than 15 years.

The Contractor shall provide the Engineer with job references where they have successfully completed 10 projects using moisture activated hydrophobic polyurethane resins for soil stabilization.

**B. Delivery, Storage and Handling**

Deliver the specified products in original, unopened containers with manufacturer's name, labels, product identification, and batch numbers intact. Store and condition the specified product as recommended by the manufacturer.

**C. Site Conditions**

Do not apply the material if it is or it appears that it will be raining or snowing unless precautions are taken to protect the material from moisture. If temperature is or will be below 34°F protect grout from freezing. Ice or the formation of ice can prevent grout penetration and travel.

Contractor shall take all precautions necessary to insure that no damage will occur to any work zone due to handling or pumping of the polyurethane resin.

**Materials****A. Acceptable Products**

The proposed product shall meet or exceed the specified performance criteria, tested in accordance with the specified test standards, and documented proof that the proposed product has a proven record of performance of soil stabilization, confirmed by actual field tests and five successful installations that the Engineer can investigate.

The installing Contractor must have a minimum of at least 10 successful soil stabilization projects utilizing moisture activated hydrophobic polyurethane injection resins and be able to provide project lists and references to the Engineer.

**B. Performance Criteria**

(1) Physical properties of polyurethane resin:

- i. Water activated resin
- ii. Variable cure rate



- iii. Viscosity: 110-130 cps  $\pm$  20 cps
- iv. Solids Content: 100% solids
- v. Characteristics: Hydrophobic polymer
- vi. Meets ANSI/NSF 61 Approval

(2) Physical properties of catalyst:

- i. Appearance: Clear liquid
- ii. Viscosity: 15-20 cps
- iii. Solids Content: 100%

(3) Physical properties of polyurethane resin cured under pressure:

- i. Shrinkage (ASTM D-1042 / D-756): None
- ii. Meets ANSI/NSF 61 Approval
- iii. Tensile Properties (ASTM D-1623)
  - 1. Tensile strength: 23 psi
  - 2. Elongation: 3%

### **C. Polyurethane Resin Specifications**

Polyurethane resin shall be a single component material that requires catalyst. Adjusting the percentage of catalyst to the base resin shall control the reaction time of the grout.

The Material shall be a water reactive grout.

Polyurethane resin shall be hydrophobic in nature.

## **Construction Methods**

### **A. Preparation**

The Contractor shall be responsible for performing any subsurface utility investigation necessary to ensure the work described by this provision does not impact any existing utility. The Contractor is also responsible for any soil analysis/subsurface inventory that may be needed to determine proper probe placement, to identify potential problem areas and natural differences in soil composition.

The Contractor shall determine appropriate spacing and depth placement for injection probes to successfully seal and stabilize area as shown in drawings. Test sections may be necessary to determine best probe spacing depending on soil types and conditions encountered. (Typical spacing will vary between 12" to 60" in each direction and if multiple rows are needed then each row shall be offset 1/2 the space distance.)

Probes shall utilize Expendable Drive Point or other acceptable means to keep dirt from clogging pipe during driving, type and size to be determined by Contractor. Probes may be placed by manual driver, pneumatic driver, auger, or water jetting.

Prior to injecting grout Contractor shall ensure that the soils contain enough moisture to fully react the grout or shall use a plural component pump to inject water and grout simultaneously (twin streaming) through injection pipe/probe. When twin streaming is done a ratio of 10:1 (grout:water) shall be used. A pump capable of injection pressures from 100 psi to 3300 psi is recommended. Flow rate of pumps shall be 2.0 gpm minimum. Manually operated or "hand pumps" are considered unacceptable and cannot be used.

A grout log shall be maintained recording amount of grout and percentage of catalyst used for inspection by the Engineer at all times. Request for payment of grout shall include a copy of grout log detailing quantities used.

**B. Application**

Contractor shall determine the amount of grout to be injected into each probe to ensure all areas with the work area are fully grouted. Grouting shall use the "Lift Grouting Technique" where the pipe is raised or jacked up and grout is injected in 12" to 15" intervals or lifts. The amount of grout to be injected at each lift is to be determined by the Contractor based on soil conditions for that particular area. Injection pressures will vary depending on soil conditions.

On below grade structures grouting can also be done via the "through wall" method. This involves drilling holes through a wall (or floor) and grouting via these holes. In some cases it may be necessary to install soil pipes to transfer grout further out into the soils. The Contractor shall determine appropriate hole spacing to ensure desired results.

Adhere to all limitations and cautions set forth by the manufacturer.

**C. Safety**

A copy of the Data sheet and Material Safety Data Sheet (MSDS) of all chemicals used must be on site at all times. Workers must wear protective rubber gloves, full protection (front and side) safety glasses, chemical goggles or face shield and any other necessary precautions as outlined in product MSDS when handling or pumping grout.

**D. Cleaning**

Flush the pump and hoses with approved pump flush. Follow the manufactures recommendations if the material comes in contact with the skin. The uncured polyurethane resin can be removed from tools with an approved solvent. Cured polyurethane can only be removed mechanically.

Remove all pipes from the work area and leave the work area clean and neat.

**E. Measurement and Payment**

*Foam Installation Soil Stabilization* will be measured and paid for per gallon. Such price and payment will be full compensation for all material, labor, tools, equipment and incidentals necessary to satisfactorily complete the work described in this provision.

Payment will be made under:

<b>Pay Item</b>	<b>Pay Unit</b>
Foam Installation Soil Stabilization	Gallons

**JOINT CONSTRUCTION, REPAIR AND SEALING:**

(4-15-08) (Rev 11-24-09)

SPI 7-12A

**Description**

Saw existing backer rods joints, saw existing sawed joints, remove existing deteriorated backer rods and clean and seal joints with Low Modulus Silicone in accordance with the detail in the plans and the manufacturer’s recommendations. Also, repair and reseal existing joints with Low Modulus Silicone, form joints in slab replacements and seal with Low Modulus Silicone in accordance with Standard Drawing No. 700.01.

**Materials**

Low Modulus Silicone Sealant shall meet the requirements of Section 1028-3(A) of the *Standard Specifications* for Low Modulus Silicone Sealant; and shall be on the Department’s approved product listing that is being evaluated by National Transportation Product Evaluation Program (NTPEP).

**Construction**

Have on-site, a manufacturer’s representative during the initial start-up. This requirement will be suspended once the Engineer determines that the installation process is working smoothly.

Saw and seal pavement joints, and form control joints in one lane at a time.

# SJ-8

I-5770

MECKLENBURG COUNTY

Saw and seal joints at locations shown on the plans or as directed by the Engineer.

Saw and seal the centerline longitudinal joint according to Standard Drawing No. 700.01.

Form control joints in the proposed replacement slabs according to the spacing and dimensions as shown on the plans. Form the control joints by sawing with an approved concrete saw. Saw as soon as the concrete has hardened sufficiently without spalling or raveling, but before the lane is reopened to traffic, and not more than 6 hours after the concrete is placed.

Equip air compressors for cleaning joints with suitable traps capable of removing all surplus water and oil in the compressed air. The Engineer will check the compressed air daily for contamination. Do not use contaminated air.

Cleaning and sealing shall be as follows:

## **(A) Cleaning Freshly Cut Sawed Joints**

Immediately after sawing the joint, completely remove the resulting slurry from the joint and the immediate area by flushing with a jet of water under pressure, and other tools as necessary. After flushing, blow out the joint with compressed air. After the surfaces are thoroughly clean and dry and just before the joint sealer is placed, blow out the joint with compressed air having a pressure of at least 90 psi and remove all traces of dust. If freshly cut sawed joints become contaminated before they are sealed, clean as many times as necessary with cleaning methods approved by the Engineer.

## **(B) Installing Backup Material**

When required, install closed cell, expanded polyethylene foam rod type backup material in a manner that will produce the shape factor specified. If the sealant bonds to the backup material, a bond-breaking type may be required.

## **(C) Taping Expansion Joints**

When the joints have been cleaned and are thoroughly dry, place bond-breaking adhesive tape on top of the joint material or backup material to prevent any bonding action between the bottom of the joint sealer and the top of underlying material. The tape shall completely cover the top of the underlying material, but at no place shall the tape be allowed to adhere to the sides of the joint.

## **(D) Sealing Joints Requirements**

- (1) Place joint sealer in accordance with the manufacturer's recommendations and these Specifications. Do not place silicone joint sealer when the air temperature near the joint is less than 50°F or is 50°F and falling or between October 15 and May 1, unless otherwise directed by the Engineer.

# SJ-9

I-5770

MECKLENBURG COUNTY

- (2) Filling the Joint: Do not seal a joint until the seal is thoroughly clean and dry, and properly taped, if taping is required. Place the sealer in reasonably close conformity with dimensions shown on the plans. The joints will be rejected for any unreasonable deviation until satisfactory corrective measures are taken.

Apply the joint sealer by an approved mechanical device or by manually pouring or troweling, depending upon the consistency used. When applied mechanically or by pouring, a nozzle or pouring spout shall be shaped to fit inside the joint to introduce the sealer from inside the joint. Pouring consistency shall be used in horizontal joints, and troweling consistency shall be used in vertical joints, unless the pouring consistency is such that it can be satisfactorily placed in vertical joints.

Recess the joint sealer below the adjacent surface as shown in Standard Drawing No. 700.01.

If the joint material fails in either adhesion or cohesion, the joint shall be repaired to the Engineer's satisfaction at the Contractor's expense.

- (3) Special Requirements for Installation of Low Modulus Silicone Sealant: The sealant shall be tooled to provide the required recess. The sealant shall be tooled or applied in a manner which causes it to wet the joint faces.
- (4) Cleaning Pavement: Promptly remove surplus joint sealer on the pavement after a joint has been sealed so that the joint sealer is not exposed to direct contact with traffic.

## **(E) Opening to Traffic**

Do not permit traffic over sealed joints without the approval of the Engineer.

## **Measurement and Payment**

*Joint Construction, Repair and Sealing* will be measured and paid for at the contract unit price of the actual number of linear feet of joints, which are satisfactorily constructed, repaired and sealed. The length will be measured along the joints that have been constructed or repaired and sealed. Such price and payment will be full compensation for this work, including but not limited to removal and disposal of existing joint sealant and backer rod, preparation of joints, and furnishing all labor, tools, materials, and supplies, tools equipment and incidentals needed to complete the work.

Payment will be made under:

### **Pay Item**

Joint Construction, Repair and Sealing

### **Pay Unit**

Linear Foot

**Project Special Provisions  
Structures  
Table of Contents**

<b>Special Provision</b>		<b>Page</b>
Scope of Work		BP-2
Falsework and Formwork	(04-05-12)	BP-2
Crane Safety	(08-15-05)	BP-8
Grout for Structures	(12-01-17)	BP-9
Submittal of Working Drawings	(06-28-17)	BP-10
Volumetric Mixer	(12-18-12)	BP-14
Concrete for Deck Repair	(12-18-12)	BP-15
Overlay Surface Preparation for Polyester Polymer Concrete	(SPECIAL)	BP-17
Polyester Polymer Concrete Bridge Deck Overlay	(SPECIAL)	BP-23
Bridge Joint Demolition	(SPECIAL)	BP-33
Foam Joint Seals	(SPECIAL)	BP-34
Expansion Joint Seal Repair	(SPECIAL)	BP-37
Strip Seal Expansion Joint	(12/18/2012)	BP-41
Partial Removal of Existing Structure	(SPECIAL)	BP-44
Additional Reinforcing Steel	(SPECIAL)	BP-44

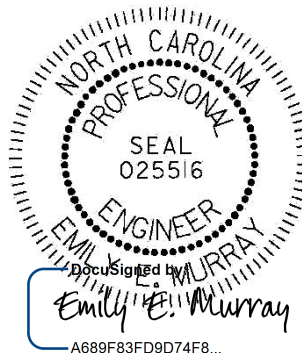

1/25/2018

**SCOPE OF WORK**

This work shall consist of furnishing all labor, equipment, and materials to overlay existing bridge decks with polyester polymer concrete as directed in the plans. Work includes: portable lighting; concrete deck repair, bridge deck surface preparation; overlaying the prepared bridge deck with Polyester Polymer concrete overlay; existing joint removal and reconstruction; replacement of expansion joint seals; installation of foam joint seals; grooving bridge floor; seeding and mulching all grassed areas disturbed; disposal of waste material and all incidental items necessary to complete the project as specified and shown on the plans. No separate payment will be made for portable lighting as the cost of such is incidental to the work being performed.

Work will be performed on the existing bridges at the following locations:

- 1.) Mecklenburg County Bridge No. 71 – on I-85 over SR 1914 (Tuckaseegee Rd.)
- 2.) Mecklenburg County Bridge No. 113 – on I-85 NBL over Little Rock Rd.
- 3.) Mecklenburg County Bridge No. 115 – on I-85 NBL over Little Rock Rd.
- 4.) Mecklenburg County Bridge No. 819 – on I-85 over I-485.

Contractor shall provide all necessary access; provide all traffic control; provide all staging areas; material storage; waste disposal; provide environmental controls to limit loss of materials from collection of sawing equipment and chipping equipment; and all else necessary to complete the work.

The contractor shall be responsible for fulfilling all requirements of the NCDOT Standard Specifications for Roads and Structures dated January 2018, except as otherwise specified herein.

**FALSEWORK AND FORMWORK****(4-5-12)****1.0 DESCRIPTION**

Use this Special Provision as a guide to develop temporary works submittals required by the Standard Specifications or other provisions; no additional submittals are required herein. Such temporary works include, but are not limited to, falsework and formwork.

Falsework is any temporary construction used to support the permanent structure until it becomes self-supporting. Formwork is the temporary structure or mold used to retain plastic or fluid concrete in its designated shape until it hardens. Access scaffolding is a temporary structure that functions as a work platform that supports construction personnel, materials, and tools, but is not intended to support the structure. Scaffolding systems that are used to temporarily support permanent structures (as opposed to functioning as work platforms) are considered to be falsework under the definitions given. Shoring is a component of falsework such as horizontal, vertical, or inclined support members. Where the term “temporary works” is used, it includes all of the temporary facilities used in bridge construction that do not become part of the permanent structure.

Design and construct safe and adequate temporary works that will support all loads imposed and provide the necessary rigidity to achieve the lines and grades shown on the plans in the final structure.

## 2.0 MATERIALS

Select materials suitable for temporary works; however, select materials that also ensure the safety and quality required by the design assumptions. The Engineer has authority to reject material on the basis of its condition, inappropriate use, safety, or nonconformance with the plans. Clearly identify allowable loads or stresses for all materials or manufactured devices on the plans. Revise the plan and notify the Engineer if any change to materials or material strengths is required.

## 3.0 DESIGN REQUIREMENTS

### A. Working Drawings

Provide working drawings for items as specified in the contract, or as required by the Engineer, with design calculations and supporting data in sufficient detail to permit a structural and safety review of the proposed design of the temporary work.

On the drawings, show all information necessary to allow the design of any component to be checked independently as determined by the Engineer.

When concrete placement is involved, include data such as the drawings of proposed sequence, rate of placement, direction of placement, and location of all construction joints. Submit the number of copies as called for by the contract.

When required, have the drawings and calculations prepared under the guidance of, and sealed by, a North Carolina Registered Professional Engineer who is knowledgeable in temporary works design.

If requested by the Engineer, submit with the working drawings manufacturer's catalog data listing the weight of all construction equipment that will be supported on the temporary work. Show anticipated total settlements and/or deflections of falsework and forms on the working drawings. Include falsework footing settlements, joint take-up, and deflection of beams or girders.

As an option for the Contractor, overhang falsework hangers may be uniformly spaced, at a maximum of 36 inches, provided the following conditions are met:

Member Type (PCG)	Member Depth, (inches)	Max. Overhang Width, (inches)	Max. Slab Edge Thickness, (inches)	Max. Screenshot Wheel Weight, (lbs.)	Bracket Min. Vertical Leg Extension, (inches)
II	36	39	14	2000	26
III	45	42	14	2000	35
IV	54	45	14	2000	44
MBT	63	51	12	2000	50
MBT	72	55	12	1700	48



Overhang width is measured from the centerline of the girder to the edge of the deck slab.

For Type II, III & IV prestressed concrete girders (PCG), 45-degree cast-in-place half hangers and rods must have a minimum safe working load of 6,000 lbs.

For MBT prestressed concrete girders, 45-degree angle holes for falsework hanger rods shall be cast through the girder top flange and located, measuring along the top of the member, 1'-2 1/2" from the edge of the top flange. Hanger hardware and rods must have a minimum safe working load of 6,000 lbs.

The overhang bracket provided for the diagonal leg shall have a minimum safe working load of 3,750 lbs. The vertical leg of the bracket shall extend to the point that the heel bears on the girder bottom flange, no closer than 4 inches from the bottom of the member. However, for 72-inch members, the heel of the bracket shall bear on the web, near the bottom flange transition.

Provide adequate overhang falsework and determine the appropriate adjustments for deck geometry, equipment, casting procedures and casting conditions.

If the optional overhang falsework spacing is used, indicate this on the falsework submittal and advise the girder producer of the proposed details. Failure to notify the Engineer of hanger type and hanger spacing on prestressed concrete girder casting drawings may delay the approval of those drawings.

Falsework hangers that support concentrated loads and are installed at the edge of thin top flange concrete girders (such as bulb tee girders) shall be spaced so as not to exceed 75% of the manufacturer's stated safe working load. Use of dual leg hangers (such as Meadow Burke HF-42 and HF-43) are not allowed on concrete girders with thin top flanges. Design the falsework and forms supporting deck slabs and overhangs on girder bridges so that there will be no differential settlement between the girders and the deck forms during placement of deck concrete.

When staged construction of the bridge deck is required, detail falsework and forms for screed and fluid concrete loads to be independent of any previous deck pour components when the mid-span girder deflection due to deck weight is greater than 3/4".

Note on the working drawings any anchorages, connectors, inserts, steel sleeves or other such devices used as part of the falsework or formwork that remains in the permanent structure. If the plan notes indicate that the structure contains the necessary corrosion protection required for a Corrosive Site, epoxy coat, galvanize or metalize these devices. Electroplating will not be allowed. Any coating required by the Engineer will be considered incidental to the various pay items requiring temporary works.

Design falsework and formwork requiring submittals in accordance with the 1995 AASHTO *Guide Design Specifications for Bridge Temporary Works* except as noted herein.

1. Wind Loads

Table 2.2 of Article 2.2.5.1 is modified to include wind velocities up to 110 mph. In

addition, Table 2.2A is included to provide the maximum wind speeds by county in North Carolina.

**Table 2.2 - Wind Pressure Values**

Height Zone feet above ground	Pressure, lb/ft <sup>2</sup> for Indicated Wind Velocity, mph				
	70	80	90	100	110
0 to 30	15	20	25	30	35
30 to 50	20	25	30	35	40
50 to 100	25	30	35	40	45
over 100	30	35	40	45	50

## 2. Time of Removal

The following requirements replace those of Article 3.4.8.2.

Do not remove forms until the concrete has attained strengths required in Article 420-16 of the Standard Specifications and these Special Provisions.

Do not remove forms until the concrete has sufficient strength to prevent damage to the surface.

**Table 2.2A - Steady State Maximum Wind Speeds by Counties in North Carolina**

COUNTY	25 YR (mph)	COUNTY	25 YR (mph)	COUNTY	25 YR (mph)
Alamance	70	Franklin	70	Pamlico	100
Alexander	70	Gaston	70	Pasquotank	100
Alleghany	70	Gates	90	Pender	100
Anson	70	Graham	80	Perquimans	100
Ashe	70	Granville	70	Person	70
Avery	70	Greene	80	Pitt	90
Beaufort	100	Guilford	70	Polk	80
Bertie	90	Halifax	80	Randolph	70
Bladen	90	Harnett	70	Richmond	70
Brunswick	100	Haywood	80	Robeson	80
Buncombe	80	Henderson	80	Rockingham	70
Burke	70	Hertford	90	Rowan	70
Cabarrus	70	Hoke	70	Rutherford	70
Caldwell	70	Hyde	110	Sampson	90
Camden	100	Iredell	70	Scotland	70
Carteret	110	Jackson	80	Stanley	70
Caswell	70	Johnston	80	Stokes	70
Catawba	70	Jones	100	Surry	70
Cherokee	80	Lee	70	Swain	80
Chatham	70	Lenoir	90	Transylvania	80
Chowan	90	Lincoln	70	Tyrell	100
Clay	80	Macon	80	Union	70
Cleveland	70	Madison	80	Vance	70
Columbus	90	Martin	90	Wake	70
Craven	100	McDowell	70	Warren	70
Cumberland	80	Mecklenburg	70	Washington	100
Currituck	100	Mitchell	70	Watauga	70
Dare	110	Montgomery	70	Wayne	80
Davidson	70	Moore	70	Wilkes	70
Davie	70	Nash	80	Wilson	80
Duplin	90	New Hanover	100	Yadkin	70
Durham	70	Northampton	80	Yancey	70
Edgecombe	80	Onslow	100		
Forsyth	70	Orange	70		

#### B. Review and Approval

The Engineer is responsible for the review and approval of temporary works' drawings.

Submit the working drawings sufficiently in advance of proposed use to allow for their review, revision (if needed), and approval without delay to the work.

The time period for review of the working drawings does not begin until complete drawings and design calculations, when required, are received by the Engineer.

Do not start construction of any temporary work for which working drawings are required until the drawings have been approved. Such approval does not relieve the Contractor of the responsibility for the accuracy and adequacy of the working drawings.

#### **4.0 CONSTRUCTION REQUIREMENTS**

All requirements of Section 420 of the Standard Specifications apply.

Construct temporary works in conformance with the approved working drawings. Ensure that the quality of materials and workmanship employed is consistent with that assumed in the design of the temporary works. Do not weld falsework members to any portion of the permanent structure unless approved. Show any welding to the permanent structure on the approved construction drawings.

Provide tell-tales attached to the forms and extending to the ground, or other means, for accurate measurement of falsework settlement. Make sure that the anticipated compressive settlement and/or deflection of falsework does not exceed 1 inch. For cast-in-place concrete structures, make sure that the calculated deflection of falsework flexural members does not exceed 1/240 of their span regardless of whether or not the deflection is compensated by camber strips.

##### **A. Maintenance and Inspection**

Inspect and maintain the temporary work in an acceptable condition throughout the period of its use. Certify that the manufactured devices have been maintained in a condition to allow them to safely carry their rated loads. Clearly mark each piece so that its capacity can be readily determined at the job site.

Perform an in-depth inspection of an applicable portion(s) of the temporary works, in the presence of the Engineer, not more than 24 hours prior to the beginning of each concrete placement. Inspect other temporary works at least once a month to ensure that they are functioning properly. Have a North Carolina Registered Professional Engineer inspect the cofferdams, shoring, sheathing, support of excavation structures, and support systems for load tests prior to loading.

##### **B. Foundations**

Determine the safe bearing capacity of the foundation material on which the supports for temporary works rest. If required by the Engineer, conduct load tests to verify proposed bearing capacity values that are marginal or in other high-risk situations.

The use of the foundation support values shown on the contract plans of the permanent structure is permitted if the foundations are on the same level and on the same soil as those of the permanent structure.

Allow for adequate site drainage or soil protection to prevent soil saturation and washout

of the soil supporting the temporary works supports.

If piles are used, the estimation of capacities and later confirmation during construction using standard procedures based on the driving characteristics of the pile is permitted. If preferred, use load tests to confirm the estimated capacities; or, if required by the Engineer conduct load tests to verify bearing capacity values that are marginal or in other high risk situations.

The Engineer reviews and approves the proposed pile and soil bearing capacities.

## 5.0 REMOVAL

Unless otherwise permitted, remove and keep all temporary works upon completion of the work. Do not disturb or otherwise damage the finished work.

Remove temporary works in conformance with the contract documents. Remove them in such a manner as to permit the structure to uniformly and gradually take the stresses due to its own weight.

## 6.0 METHOD OF MEASUREMENT

Unless otherwise specified, temporary works will not be directly measured.

## 7.0 BASIS OF PAYMENT

Payment at the contract unit prices for the various pay items requiring temporary works will be full compensation for the above falsework and formwork.

## **CRANE SAFETY**

**(8-15-05)**

Comply with the manufacturer specifications and limitations applicable to the operation of any and all cranes and derricks. Prime contractors, sub-contractors, and fully operated rental companies shall comply with the current Occupational Safety and Health Administration regulations (OSHA).

Submit all items listed below to the Engineer prior to beginning crane operations involving critical lifts. A critical lift is defined as any lift that exceeds 75 percent of the manufacturer's crane chart capacity for the radius at which the load will be lifted or requires the use of more than one crane. Changes in personnel or equipment must be reported to the Engineer and all applicable items listed below must be updated and submitted prior to continuing with crane operations.

### **Crane Safety Submittal List**

- **Competent Person:** Provide the name and qualifications of the "Competent Person" responsible for crane safety and lifting operations. The named competent person will have the responsibility and authority to stop any work activity due to safety concerns.
- **Riggers:** Provide the qualifications and experience of the persons responsible for rigging operations. Qualifications and experience should include, but not be limited to, weight calculations, center of gravity determinations, selection and inspection of sling and rigging equipment, and safe rigging practices.

- **Crane Inspections:** Inspection records for all cranes shall be current and readily accessible for review upon request.

**Certifications:** By July 1, 2006, crane operators performing critical lifts shall be certified by NC CCO (National Commission for the Certification of Crane Operators), or satisfactorily complete the Carolinas AGC's Professional Crane Operator's Proficiency Program. Other approved nationally accredited programs will be considered upon request. All crane operators shall also have a current CDL medical card. Submit a list of anticipated critical lifts and corresponding crane operator(s). Include current certification for the type of crane operated (small hydraulic, large hydraulic, small lattice, large lattice) and medical evaluations for each operator.

## **GROUT FOR STRUCTURES**

**(12-1-17)**

### **DESCRIPTION**

This special provision addresses grout for use in pile blockouts, grout pockets, shear keys, dowel holes and recesses for structures. This provision does not apply to grout placed in post-tensioning ducts for bridge beams, girders, decks, end bent caps, or bent caps. Mix and place grout in accordance with the manufacturer's recommendations, the applicable sections of the Standard Specifications and this provision.

### **MATERIAL REQUIREMENTS**

Unless otherwise noted on the plans, use a Type 3 Grout in accordance with Section 1003 of the Standard Specifications.

Initial setting time shall not be less than 10 minutes when tested in accordance with ASTM C266.

Construction loading and traffic loading shall not be allowed until the 3 day compressive strength is achieved.

### **SAMPLING AND PLACEMENT**

Place and maintain components in final position until grout placement is complete and accepted. Concrete surfaces to receive grout shall be free of defective concrete, laitance, oil, grease and other foreign matter. Saturate concrete surfaces with clean water and remove excess water prior to placing grout.

### **BASIS OF PAYMENT**

No separate payment will be made for "Grout for Structures". The cost of the material, equipment, labor, placement, and any incidentals necessary to complete the work shall be considered incidental to the structure item requiring grout.

**SUBMITTAL OF WORKING DRAWINGS****(6-28-17)****GENERAL**

Submit working drawings in accordance with Article 105-2 of the *Standard Specifications* and this provision. For this provision, “submittals” refers to only those listed in this provision. The list of submittals contained herein does not represent a list of required submittals for the project. Submittals are only necessary for those items as required by the contract. Make submittals that are not specifically noted in this provision directly to the Engineer. Either the Structures Management Unit or the Geotechnical Engineering Unit or both units will jointly review submittals.

If a submittal contains variations from plan details or specifications or significantly affects project cost, field construction or operations, discuss the submittal with and submit all copies to the Engineer. State the reason for the proposed variation in the submittal. To minimize review time, make sure all submittals are complete when initially submitted. Provide a contact name and information with each submittal. Direct any questions regarding submittal requirements to the Engineer, Structures Management Unit contacts or the Geotechnical Engineering Unit contacts noted below.

In order to facilitate in-plant inspection by NCDOT and approval of working drawings, provide the name, address and telephone number of the facility where fabrication will actually be done if different than shown on the title block of the submitted working drawings. This includes, but is not limited to, precast concrete items, prestressed concrete items and fabricated steel or aluminum items.

**ADDRESSES AND CONTACTS**

For submittals to the Structures Management Unit, use the following addresses:

## Via US mail:

Mr. B. C. Hanks, P. E.  
State Structures Engineer  
North Carolina Department  
of Transportation  
Structures Management Unit  
1581 Mail Service Center  
Raleigh, NC 27699-1581

Attention: Mr. J. L. Bolden, P. E.

## Via other delivery service:

Mr. B. C. Hanks, P. E.  
State Structures Engineer  
North Carolina Department  
of Transportation  
Structures Management Unit  
1000 Birch Ridge Drive  
Raleigh, NC 27610

Attention: Mr. J. L. Bolden, P. E.

Submittals may also be made via email.

Send submittals to:

[jlbolden@ncdot.gov](mailto:jlbolden@ncdot.gov) (James Bolden)

Send an additional e-copy of the submittal to the following address:

[eomile@ncdot.gov](mailto:eomile@ncdot.gov) (Emmanuel Omile)

[mrorie@ncdot.gov](mailto:mrorie@ncdot.gov) (Madonna Rorie)

For submittals to the Geotechnical Engineering Unit, use the following addresses:

For projects in Divisions 1-7, use the following Eastern Regional Office address:

Via US mail:

Mr. Chris Kreider, P. E.  
Eastern Regional Geotechnical  
Manager  
North Carolina Department  
of Transportation  
Geotechnical Engineering Unit  
Eastern Regional Office  
1570 Mail Service Center  
Raleigh, NC 27699-1570

Via other delivery service:

Mr. Chris Kreider, P. E.  
Eastern Regional Geotechnical  
Manager  
North Carolina Department  
of Transportation  
Geotechnical Engineering Unit  
Eastern Regional Office  
3301 Jones Sausage Road, Suite 100  
Garner, NC 27529

Via Email: [EastGeotechnicalSubmittal@ncdot.gov](mailto:EastGeotechnicalSubmittal@ncdot.gov)

For projects in Divisions 8-14, use the following Western Regional Office address:

Via US mail or other delivery service:

Mr. Eric Williams, P. E.  
Western Regional Geotechnical Manager  
North Carolina Department  
of Transportation  
Geotechnical Engineering Unit  
Western Regional Office  
5253 Z Max Boulevard  
Harrisburg, NC 28075

Via Email: [WestGeotechnicalSubmittal@ncdot.gov](mailto:WestGeotechnicalSubmittal@ncdot.gov)

The status of the review of structure-related submittals sent to the Structures Management Unit can be viewed from the Unit's website, via the "Drawing Submittal Status" link.

The status of the review of geotechnical-related submittals sent to the Geotechnical Engineering Unit can be viewed from the Unit's website, via the "Geotechnical Construction Submittals" link.

Direct any questions concerning submittal review status, review comments or drawing markups to the following contacts:

Primary Structures Contact:	James Bolden (919) 250 – 4082 facsimile <a href="mailto:jlbolden@ncdot.gov">jlbolden@ncdot.gov</a>	(919) 707 – 6408
Secondary Structures Contacts:	Emmanuel Omile Madonna Rorie	(919) 707 – 6451 (919) 707 – 6508
Eastern Regional Geotechnical Contact (Divisions 1-7):	Chris Kreider <a href="mailto:ckreider@ncdot.gov">ckreider@ncdot.gov</a>	(919) 662 – 4710



Western Regional Geotechnical Contact (Divisions 8-14):

Eric Williams

(704) 455 – 8902

[ewilliams3@ncdot.gov](mailto:ewilliams3@ncdot.gov)

### **SUBMITTAL COPIES**

Furnish one complete copy of each submittal, including all attachments, to the Engineer. At the same time, submit the number of hard copies shown below of the same complete submittal directly to the Structures Management Unit and/or the Geotechnical Engineering Unit.

The first table below covers “Structure Submittals”. The Engineer will receive review comments and drawing markups for these submittals from the Structures Management Unit. The second table in this section covers “Geotechnical Submittals”. The Engineer will receive review comments and drawing markups for these submittals from the Geotechnical Engineering Unit.

Unless otherwise required, submit one set of supporting calculations to either the Structures Management Unit or the Geotechnical Engineering Unit unless both units require submittal copies in which case submit a set of supporting calculations to each unit. Provide additional copies of any submittal as directed.

### **STRUCTURE SUBMITTALS**

<b>Submittal</b>	<b>Copies Required by Structures Management Unit</b>	<b>Copies Required by Geotechnical Engineering Unit</b>	<b>Contract Reference Requiring Submittal <sup>1</sup></b>
Arch Culvert Falsework	5	0	Plan Note, SN Sheet & “Falsework and Formwork”
Box Culvert Falsework <sup>7</sup>	5	0	Plan Note, SN Sheet & “Falsework and Formwork”
Cofferdams	6	2	Article 410-4
Foam Joint Seals <sup>6</sup>	9	0	“Foam Joint Seals”
Expansion Joint Seals (hold down plate type with base angle)	9	0	“Expansion Joint Seals”
Expansion Joint Seals (modular)	2, then 9	0	“Modular Expansion Joint Seals”
Expansion Joint Seals (strip seals)	9	0	“Strip Seals”

Falsework & Forms <sup>2</sup> (substructure)	8	0	Article 420-3 & “Falsework and Formwork”
Falsework & Forms (superstructure)	8	0	Article 420-3 & “Falsework and Formwork”
Girder Erection over Railroad	5	0	Railroad Provisions
Maintenance and Protection of Traffic Beneath Proposed Structure	8	0	“Maintenance and Protection of Traffic Beneath Proposed Structure at Station ____”
Metal Bridge Railing	8	0	Plan Note
Metal Stay-in-Place Forms	8	0	Article 420-3
Metalwork for Elastomeric Bearings <sup>4,5</sup>	7	0	Article 1072-8
Miscellaneous Metalwork <sup>4,5</sup>	7	0	Article 1072-8
Disc Bearings <sup>4</sup>	8	0	“Disc Bearings”
Overhead and Digital Message Signs (DMS) (metalwork and foundations)	13	0	Applicable Provisions
Placement of Equipment on Structures (cranes, etc.)	7	0	Article 420-20
Precast Concrete Box Culverts	2, then 1 reproducible	0	“Optional Precast Reinforced Concrete Box Culvert at Station ____”
Prestressed Concrete Cored Slab (detensioning sequences) <sup>3</sup>	6	0	Article 1078-11
Prestressed Concrete Deck Panels	6 and 1 reproducible	0	Article 420-3
Prestressed Concrete Girder (strand elongation and detensioning sequences)	6	0	Articles 1078-8 and 1078- 11
Removal of Existing Structure over Railroad	5	0	Railroad Provisions
Revised Bridge Deck Plans (adaptation to prestressed deck panels)	2, then 1 reproducible	0	Article 420-3
Revised Bridge Deck Plans (adaptation to modular expansion joint seals)	2, then 1 reproducible	0	“Modular Expansion Joint Seals”

Sound Barrier Wall (precast items)	10	0	Article 1077-2 & “Sound Barrier Wall”
Sound Barrier Wall Steel Fabrication Plans <sup>5</sup>	7	0	Article 1072-8 & “Sound Barrier Wall”
Structural Steel <sup>4</sup>	2, then 7	0	Article 1072-8
Temporary Detour Structures	10	2	Article 400-3 & “Construction, Maintenance and Removal of Temporary Structure at Station _____”
TFE Expansion Bearings <sup>4</sup>	8	0	Article 1072-8

**FOOTNOTES**

1. References are provided to help locate the part of the contract where the submittals are required. References in quotes refer to the provision by that name. Articles refer to the *Standard Specifications*.
2. Submittals for these items are necessary only when required by a note on plans.
3. Submittals for these items may not be required. A list of pre-approved sequences is available from the producer or the Materials & Tests Unit.
4. The fabricator may submit these items directly to the Structures Management Unit.
5. The two sets of preliminary submittals required by Article 1072-8 of the *Standard Specifications* are not required for these items.
6. Submittals for Fabrication Drawings are not required. Submittals for Catalogue Cuts of Proposed Material are required. See Section 5.A of the referenced provision.
7. Submittals are necessary only when the top slab thickness is 18” or greater.

**VOLUMETRIC MIXER****(12-18-12)****DESCRIPTION**

This provision addresses the requirements for batching deck repair concrete at the point of delivery using a Mobile High Performance Volume Mixer (MHPVM). Work shall be in accordance with the general requirements of Section 1000-12 of the *Standard Specifications* and as amended by these provisions.

**MATERIALS**

Produce high early strength concrete with MHPVM equipment. Furnish project site storage facilities that will provide protection of materials in accordance with the *Standard Specifications* and all material suppliers’ recommendations.

**EQUIPMENT**

MHPVM devices shall have prominently displayed stamped metal plate(s) from the Volumetric Mixers Manufacturers Bureau stating that the equipment conforms to the requirements of ASTM C685.

Hydraulic cement concrete shall be mixed at the point of delivery by a combination of materials and

mixer unit conforming to the following:

- 1.) The unit shall be equipped with calibrated proportioning devices for each ingredient added to the concrete mix. The unit shall be equipped with a working recording meter that is visible at all times and furnishes a ticket printout with the calibrated measurement of the mix being produced. If at any time the mixer fails to discharge a uniform mix, production of concrete shall be suspended until such time that problems are corrected.
- 2.) Each unit shall have prominently displayed stamped metal plate(s) attached by the manufacturer on which the following are plainly marked: the gross volume of the transportation unit in terms of mixed concrete, the discharge speed and the mass calibrated constant of the machine in terms of volume.
- 3.) MHPVMs shall be calibrated by a Department approved testing agency in accordance with the manufacturer's recommendations at an interval of every 6 months or a maximum production of 2500 cubic yards, whichever comes first prior to use on the project. The yield shall be maintained within a tolerance of +/- 1% and verified using a minimum 2 cubic feet container every 500 cubic yards or a minimum of once per week.
- 4.) The three cubic feet initially discharged from the truck shall be discarded and not used for concrete placement. Acceptance of the concrete shall comply with the Standard Specifications except that the sample secured for acceptance testing will be taken after four cubic feet is discharged from the delivery vehicle. During discharge, the consistency as determined by ASTM C143 on representative samples taken from the mixer discharge at random intervals shall not vary by more than 1 inch. Acceptance tests shall be performed on each load. If test data demonstrates that acceptable consistency of concrete properties is being achieved, the Engineer may reduce testing requirements.
- 5.) MHPVM equipment shall be operated by a person who is a certified operator by the equipment manufacturer. Any equipment adjustments made during the on-site production of concrete shall be done under the direct on-site supervision of the producer's NCDOT Certified Concrete Batch Technician.

#### **UNIFORMITY AND ACCEPTANCE**

The contractor is responsible for providing a Certified Concrete Plant Technician during batching operations, and a Certified Concrete Field Technician during placing operations

#### **MEASUREMENT AND PAYMENT**

*Volumetric Mixer* will be paid for as lump sum and will be full compensation for furnishing the certified MHPVM devices and calibration of the equipment.

<b>Pay Item</b>	<b>Pay Unit</b>
Volumetric Mixer	Lump Sum

#### **CONCRETE FOR DECK REPAIR**

**(12-18-12)**

#### **DESCRIPTION**

This provision addresses the material requirements of high early strength structural concrete to be used for reconstruction of deck slab and, if necessary, bent diaphragms as noted in the plans.

**MATERIALS**

Furnish Department approved pre-packaged concrete or bulk concrete materials in a mix proportioned to satisfy provisions for Class AA Concrete detailed in Section 1000-4 of the *Standard Specifications* or as otherwise noted in these provisions. Concrete mix shall meet the following requirements:

<b>Physical Property</b>	<b>Threshold Limitation</b>	<b>Test Method</b>
Compressive Strength (at 3 hrs.)	4500 psi (min.)	ASTM C39/C109
Slump	4 in. (min.) 7 in. (max.)	AASHTO T119
Water to Cement Ratio	0.450 (max.)	N/A
Modulus of Elasticity (at 28 days)	5200 ksi (max.)	ASTM C469
Coefficient of Thermal Expansion (at 28 days)	4.5 in./in./°F (min.) 5.5 in./in./°F (max.)	AASHTO T336
Concrete Setting Times		ASTM C191
Initial	30 min. (max.)	
Final	40 min. (max)	

Concrete shall be capable of placement on existing concrete substrate surfaces within the following temperature limitations:

40<sup>0</sup> F (min.)

100<sup>0</sup> F (max.)

Measurement for determination of concrete material compositions shall be in accordance with Section 1000-8 of the *Standard Specifications*.

Submit pre-packaged concrete mix contents or concrete mix design, including laboratory compressive strength data, for a minimum of six 4-inch by 8-inch cylinders at an age of 3 hours and 1 day to the Engineer for review. Include test results for the slump and air content of the laboratory mix. Perform tests in accordance with AASHTO T119 and T152.

Provide aggregates that are free from ice, frost and frozen particles when introduced into the mixer.

For equipment, proportioning and mixing of concrete compositions, see Section 1000-12 of the *Standard Specifications* and the Special Provision entitled "Volumetric Mixer". Prior to beginning any work, obtain approval for all equipment to be used for joint area preparation, mixing, placing, finishing, and curing the deck repair concrete.

**Measurement and Payment**

*Concrete for Deck Repair* will be measured and paid for at the contract unit price bid for the actual cubic feet of concrete incorporated into the completed and accepted structure. This price and payment will be full compensation for furnishing the required amount of material to complete the deck repair.

<b>Pay Item</b>	<b>Pay Unit</b>
Concrete for Deck Repair	Cubic Feet

**OVERLAY SURFACE PREPARATION FOR****POLYESTER POLYMER CONCRETE****(SPECIAL)****DESCRIPTION**

This provision addresses the surface preparation activities required prior to the placement of polyester polymer concrete (PPC). Unless specifically mentioned below, all requirements specified for the bridge deck are also required for the approach slabs.

Work includes: removal of deck concrete for closure pour on Bridge #71; removal of unsound and sound bridge deck concrete and existing patches in deck repair areas; preparation of repair areas prior to placement of PPC bridge deck repair material; bridge deck surface preparation prior to placement of PPC overlay; and any incidentals necessary to prepare the bridge deck for placement of PPC repair material or PPC overlay, as specified or as shown on the plans.

**DEFINITIONS**

Scarification shall consist of the removal of any asphalt wearing surface and concrete surface to the uniform depth and limits shown on the plans.

Shotblasting shall consist of steel beads (or other materials as approved by the Engineer) “shot” out of a machine onto the bridge concrete deck concrete floor to remove soft or deteriorated concrete, and to clean the concrete deck surface for the application of the PPC overlay. Contractor shall vary the speed of the shotblaster or make multiple passes, as necessary, to achieve the required surface preparation for the PPC overlay. Areas inaccessible with shotblasting equipment may require surface preparation with sandblasting equipment and hand equipment.

Hydro-demolition shall consist of the removal of the deck surface by means of high pressure water blasting which will remove concrete, oil, dirt, concrete laitance and rust from the exposed reinforcing bars by direct impact, pressurization of micro and macro cracks and cavitation produced by jet instability.

**MANAGING HYDRO-DEMOLITION WATER**

Prior to beginning work, submit for approval a Hydro-demolition Management Plan. This plan shall describe the collection, treatment, and disposal of run-off water generated by the scarification and hydro-demolition processes. Prepare the plan in accordance to the NCDOT Guidelines for Managing Hydro-demolition Water (a copy of which is included in the Appendix). The contractor shall comply with applicable regulation concerning such water disposal.

**EQUIPMENT**

All equipment for cleaning the existing concrete surface and mixing and applying the overlay system shall be in accordance with the System Provider’s recommendations, as approved by the Engineer prior to commencement of any work:

- Scarifying equipment that is a power-operated, mechanical grinder capable of removing a minimum depth of ¼” for each pass.
- Shotblasting and sandblasting equipment to adequately prepare the bridge deck substrate, as required in this provision. Provide equipment to supply oil-free and moisture-free compressed air for final surface preparation.
- Hydro-demolition machine, self-propelled with a minimum orifice pressure of 17,000 psi.
- All water used for hydro-demolition shall be potable.
- Equipment capable of sawing concrete to the specified plan depth.
- Hand-held high velocity (7,500 psi minimum) water-jet equipment capable of removing rust scale from reinforcing steel, removing small chips of concrete partially loosened by the scarifying or chipping operation, and for removing rehydrated dust left from scarification.
- Power driven hand tools for removal of unsound concrete are required that meet the following requirements:
  - Pneumatic hammers weighing a nominal 15 lbs. or less.
  - Pneumatic hammer chisel-type bits that do not exceed the diameter of the shaft in width.
- Hand tools, such as hammers and chisels, for removal of final particles of unsound concrete.
- Self-propelled vacuum capable of picking up dust and other loose material from prepared deck surface.
- Equipment to supply oil-free and moisture-free compressed air for final surface preparation.

The hydro-demolition machine shall be self-propelled and capable of producing a water-jet through an orifice at a pressure of at least 17,000 psi. The machine shall move the jet transversely across the area and forward and backward so that the entire deck is covered with the water-jet and operated at a pressure sufficient to remove the unsound concrete.

The hydro-demolition machine shall have sufficient means to control and vary the following functions:

- (1) Water pressure.
- (2) Angle and distance of the orifice in relation to the surface to be blasted.
- (3) Limits of transverse and longitudinal movement of the orifice.
- (4) Speed of the orifice in the transverse and longitudinal direction.

High pressure pump(s) shall be equipped with over-pressurization relief valves and rupture disc systems. All high pressure components shall be rated at full working pressure of the hydro-demolition system. The complete hydro-demolition system must be capable of depressurization from a single point.

The equipment must operate at a noise level less than 90 decibels at a distance of 50 feet.

#### **MANAGEMENT AND DISPOSAL OF CONCRETE DEBRIS**

All concrete debris shall become the property of the Contractor. The contractor shall be responsible for disposing of all debris generated by scarification, shotblasting, sandblasting, and any other surface preparation operations, in compliance with applicable regulations concerning

such disposal.

All costs associated with management and disposal of all debris shall be included in the payment of other items.

### **OSP PLAN SUBMITTAL**

Prior to beginning surface preparation activities, the Contractor shall submit for review and approval the Overlay Surface Preparation (OSP) Plan. The OSP Plan shall detail the type of equipment that is intended to be used and the means by which the Contractor will achieve the following requirements:

- Estimate depth of reinforcing steel.
- Scarification of deck to depth required.
- Measure depth of scarification to show completed within limits.
- Measure depth of shotblasting to show completed within limits.

### **SURFACE PREPARATION**

Prior to any construction, take the necessary precautions to ensure debris from bridge deck preparation and repairs is not allowed to fall below the bridge deck.

Remove all existing asphalt overlays and all loose, disintegrated, unsound or contaminated concrete to the limits shown on the plans with the following requirements.

During surface preparation, precaution shall be taken to assure that traffic is protected from rebound, dust, and construction activities. Appropriate shielding shall be provided as required and directed by the Engineer. During surface preparation, the Contractor shall provide suitable coverings, as needed to protect all exposed areas not to receive overlay, such as curbs, sidewalks, parapets, etc. All damage or defacement resulting from surface preparation shall be repaired to the Engineer's satisfaction at no additional cost.

A. Sealing of Bridge Deck: Seal all expansion joints subject to run-off water from the scarification, shotblasting, and PPC placement process with material approved by the Engineer, prior to beginning any demolition. The expansion joints shall remain sealed until it has been determined that water and materials from the scarification, shotblasting, and PPC placement operations cannot be discharged through them any longer. Take all steps necessary to eliminate the flow of water or materials through the expansion joints, and any other locations water or materials could leak from the deck.

All deck drains in the immediate work area and other sections of the bridge affected by the work being performed shall be sealed prior to beginning scarification. Drains shall remain sealed until it has been determined that water and materials from the scarification, shotblasting, and PPC placement operations cannot be discharged through them any longer.

B. Scarifying Bridge Deck: Remove any asphalt wearing surface from the bridge deck and scarify the concrete deck to remove the entire concrete surface of the deck to the uniform depth and limits shown on the plans.

It will be the Contractor's responsibility to determine amount of cover for the reinforcing steel. Use a pachometer or other approved device, as approved by Engineer, prior to scarification. Readings shall be read and recorded in the presence of the Engineer. Readings shall be recorded for each span at 1/5 points longitudinally and 1/3 points transversely. The cost for this work will be considered incidental to the cost of surface preparation of the bridge deck.



**Estimated average cover to top mat:  
Bridge Number 71, 113, 115, 819: 2 1/2" +/- 3/8"**

The above top mat cover dimensions are an estimate based on the best available information. Calibrate scarifying equipment in order to avoid damaging the reinforcing steel in the bridge floor or the approach slab. Care shall be taken not to cut, stretch, or damage any exposed reinforcing steel. If reinforcing bars or bridge drainage devices are pulled up or snagged during scarification operations, cease work and consult with the Engineer to determine any necessary adjustments to the roto-milling operation.

Remove and dispose of all concrete and asphalt, and thoroughly clean the scarified surface. In areas where reinforcing steel is located in the depth to be scarified, use another method with the Engineer's approval.

The Engineer will re-inspect after each removal and require additional removals until compliance with plans and specifications are met.

Regardless of the method of removal, the removal operation shall be stopped if it is determined that sound concrete is being removed to a depth greater than required by the plans.

- C. Class II Surface Preparation (Partial Depth): At locations specified on the plans or identified by the Engineer for Class II Surface Preparation, verify the depth of removal achieved by the scarification. Remove by additional scarification or chipping with hand tools all existing patches and unsound concrete. No additional payment will be made for Class II Surface Preparation depths achieved by the initial scarification.

All patches shall be removed under Class II surface preparation. If any patch cannot be removed by means of scarification, the Contractor shall use hand tools to remove the patch. Areas indicated on the plans that require Class II surface preparation, including the locations of existing patches, are from the best information available. The Contractor shall verify prior to surface preparation the location of all existing patches.

Spalled or unsound areas of the deck not removed by scarification shall be removed to sound concrete at locations noted in the contract plans or as directed by the Engineer. Remove existing spalled or unsound areas of the bridge concrete deck by methods approved by the Engineer.

Provide a 1" deep saw cut around the perimeter of areas noted for bridge deck or patch removal. Remove, using the type of tools listed above, all concrete or patch material within the sawcut to a minimum depth of 1" and as necessary to remove unsound concrete. All loose and unsound concrete or patch material shall be removed.

If the condition of the concrete is such that deep spalls or sheer faces result, notify the Engineer for the proper course of action.

Thoroughly clean the newly exposed surface to be free of all grease, oil, curing compounds, acids, dirt, or loose debris in accordance with this special provision.

Dispose of the removed concrete, clean, repair or replace rusted or loose reinforcing steel, and thoroughly clean the newly exposed surface. Care shall be taken not to cut, stretch, or damage any exposed reinforcing steel.

In overhangs, removing concrete areas of less than 0.60 ft<sup>2</sup>/ft length of bridge without overhang support is permitted unless the Engineer directs otherwise. Overhang support is required for

areas removed greater than 0.60 ft<sup>2</sup>/ft length of bridge. Submit details of overhang support to the Engineer for approval prior to beginning the work.

Repair and fill the Class II surface preparation areas of the existing bridge concrete deck prior to the final surface preparation and application of the PPC overlay, at locations shown in the plans, or as determined by the Engineer, if necessary. Materials other than PPC may be used for concrete deck repairs, but shall be approved by the PPC System Provider's Technical Representative and shall be applied and prepared as required by the PPC System Provider. For concrete deck repairs with PPC:

- Removal and surface preparation of the repair area shall be in accordance with and shall be paid for under pay items in this special provision.
- Materials, equipment, placement, and finishing of PPC used for concrete deck repairs shall meet the requirements of and shall be paid for under pay items in the Polyester Polymer Concrete Bridge Deck Overlay special provision.

PPC repair material may be placed up to one (1) hour prior to overlay placement.

All repairs shall be placed and finished to match substrate deck grade prior to PPC placement, in order to provide a uniform overlay thickness.

Concrete deck repairs with PPC may be utilized as a stand-alone item where required on structures not to receive a PPC overlay.

- D. Class III Surface Preparation (Full Depth): Remove by hydro-demolition or chipping with hand tools the full depth of slab. Dispose of the removed concrete, clean, repair or replace damaged reinforcing steel and thoroughly clean the newly exposed surface. Care shall be taken not to cut, stretch, or damage any exposed reinforcing steel.

For areas of less than 3 ft<sup>2</sup> suspending forms from existing reinforcing steel using wire ties is permitted. For larger areas, support forms by blocking from the beam flanges, or other approved method.

Overhang support is required for full depth removal adjacent to bridge rails. Submit details of overhang support to the Engineer for approval prior to beginning the work.

Under Deck Containment: Under deck containment shall be installed where Class III surface preparation occurs. The containment shall be installed prior to hydro-demolition in the areas where full depth removal is required or blow thru may occur during the hydro-demolition process.

Submit for approval detailed plans for the under deck containment system. Detail how waste, debris, and wastewater are contained.

Concrete for Full Depth Repair: Fill the Class III surface preparation areas with Class AA, high early strength structural concrete or latex modified concrete in accordance with the methods described below:

Refill areas with Class AA concrete to the bottom of the proposed concrete overlay in accordance with Section 420 of the *Standard Specifications*. Any of the methods for curing Class AA concrete as stated in the *Standard Specifications* are permitted except the membrane curing compound method.

Provide a raked finish to the surface of the Class AA concrete which provides a minimum relief of 1/16" and a maximum relief of 1/4". Place the overlay course after the Class AA

concrete has attained a minimum compressive strength of 2500 psi. The strength shall be verified by an approved, non-destructive test method.

Refill the areas where concrete was removed with high early strength concrete as described in the Concrete for Deck Repair and Volumetric Mixer special provisions.

Refilling the areas from which concrete has been removed with latex modified concrete during the Class III repair is permitted if any of the following conditions are met:

- The reinforcing steel cover is 1½ inches or less for the top mat of steel.
- The area being repaired is less than 1 yd<sup>2</sup>.
- The Engineer directs the fill.

- E. Preparation of Reinforcing Steel: Remove concrete without cutting or damaging existing steel unless otherwise noted in the plans. Clean, repair, or replace rusted or loose reinforcing steel. Damaged reinforcing steel, such as bars with nicks deeper than 20% of the bar diameter, shall be repaired or replaced. Reinforcing steel which has a cross section reduced to 75% or less shall be replaced with new reinforcing steel of similar cross section area. Replacement bars shall be Grade 60 and meet the material requirements of Section 1070 of the Standard Specifications. Replacement bars shall be spliced to existing bars using either minimum 30 bar diameter lap splices to existing steel with 100% cross sectional area or approved mechanical connectors.

For reinforcing steel left unsupported by the concrete removal process, support and protect the exposed reinforcing steel against displacement and damage from loads, such as those caused by removal equipment and delivery buggies. All reinforcing steel damaged or dislodged by these operations shall be replaced with bars of the same size at the contractor's expense.

Reinforcing steel exposed and satisfactorily cleaned and prepared will not require additional cleaning, if encased in concrete within seven (7) days. Rebar exposed for more than seven (7) days shall be satisfactorily cleaned and prepared, prior to placement of the new concrete. The satisfactory cleanliness and preparation of the reinforcing steel shall be determined by the Engineer.

When large areas of the deck on composite bridges are removed resulting in the debonding of the primary reinforcing bars, the removal shall be performed in stages to comply with the construction sequence shown on the plans or as directed by the Engineer.

- F. Surface Cleaning: The surface of concrete substrate and repaired areas shall be prepared for application of the overlay by shotblasting in order to remove all existing grease, slurry, oils, paint, dirt, striping, curing compound, rust, membrane, weak surface mortar, or any other contaminants that could interfere with the proper adhesion of the overlay system. The final prepared surface shall adhere to the following requirements:
1. If expansion joints are not being replaced or have been replaced prior to shotblasting they shall be protected from damage from the shotblasting operation. Deck drains and areas of curb or railing above the proposed surface shall be protected from the shotblasting operation.
  2. The areas to receive overlay shall be cleaned by shotblasting, or abrasive sandblasting in the event that the shotblaster cannot access areas to be prepared. Do not begin shotblasting until all grinding or milling operations are completed. Cleaning shall not commence until all work involving the repair of the concrete deck surface has been completed and the deck is dry. All contaminants shall be picked up and stored in the vacuum unit and no dust shall

be created during the blasting operation that will obstruct the view of motorists in adjacent roadways. The travel speed and/or number of passes of the shotblasting unit shall be adjusted, so as to result in all weak or loose surface mortar being removed, aggregates within the concrete being exposed, and open pores in the concrete exposed, as well as a visible change in the concrete color. Cleaned surfaces shall not be exposed to vehicular traffic unless approved by the Engineer. If the deck becomes contaminated before placing the overlay, the Contractor shall shotblast or abrasive sandblast the contaminated areas to the satisfaction of the Engineer at no additional cost.

3. Prior to the overlay placement, any loose particles shall be removed by magnets and oil free compressed air and vacuuming, such that no trapped particles remain. Power washing will not be allowed.
  4. The areas to be overlaid shall be blown off with oil and moisture free compressed air just prior to placement of the primer and shall be completely dry.
  5. Cleaning methods other than those detailed by specification may be suggested by the PPC System Provider and approved by the Engineer.
  6. All steel surfaces that will be in contact with the PPC overlay shall be cleaned in accordance with SSPC-SP No. 10, Near-White Blast Cleaning, except that wet blasting methods shall not be allowed.
- G. Safety: Provide a containment system for handling expected and unexpected blow thru of the deck. The containment system shall retain runoff water and debris and protect the area under the bridge deck. The Contractor shall be responsible for any injury or damage caused by these operations. The containment system shall remain in place until the concrete has been cast and attained minimum strength.

Provide adequate lighting when performing deck preparation activities at night. Submit a lighting plan to the Engineer for approval prior to beginning work.

#### **BASIS OF PAYMENT**

*Scarifying Bridge Deck* will be measured and paid for at the contract unit price per square yard and will be full compensation for the milling of existing asphalt wearing surface from the bridge deck or approaches, milling of the entire concrete bridge deck, repairing or replacing any damaged reinforcing steel, and the cleaning and disposal of all waste material generated.

*Shotblasting Bridge Deck* will be measured and paid for at the contract unit price per square yard and will be full compensation for the shotblasting and necessary sandblasting and handwork to prepare the entire concrete bridge deck, and removal and disposal of all waste material generated.

*Class II Surface Preparation* will be measured and paid for at the contract unit price per square yard and will be full compensation for Class II deck preparation where required by the plans. The cost will also include removal and disposal of unsound and contaminated concrete, removal of all existing patches, cleaning, repairing, or replacing of reinforcing steel, and all materials, labor, tools, equipment and incidentals necessary to complete the work.

*Class III Surface Preparation* will be measured and paid for at the contract unit price per square yard and will be full compensation for Class III deck preparation where required by the plans. The cost will also include removal and disposal of unsound and contaminated concrete, cleaning, repairing or replacing of reinforcing steel, under deck containment, placing and finishing concrete for full depth repair, and for furnishing all materials, labor, tools, equipment and incidentals necessary to complete the work.

Payment will be made under:

<b><u>Pay Item</u></b>	<b><u>Pay Unit</u></b>
Scarifying Bridge Deck	Square Yard
Shotblasting Bridge Deck	Square Yard
Class II Surface Preparation	Square Yard
Class III Surface Preparation	Square Yard

**POLYESTER POLYMER CONCRETE BRIDGE DECK OVERLAY** (SPECIAL)

**DESCRIPTION**

This work consists of furnishing and placing a Polyester Polymer Concrete (PPC) overlay system with a High Molecular Weight Methacrylate (HMWM) resin primer on concrete surfaces. The surface of the concrete shall be prepared and the PPC overlay system shall be applied in accordance with this provision in conformity with the lines, grades, thickness, and typical cross-sections shown on the plans or as approved by the Engineer. Unless specifically mentioned below, all requirements specified for the bridge deck are also required for the approach slabs.

Work includes: placement of HMWM primer; placement of PPC surface patching and/or overlay; and any incidentals necessary to complete the project as specified or as shown on the plans.

The System Provider is the manufacturer that will provide the PPC system for the PPC overlay. System shall include the necessary and appropriate PPC components, as well as the necessary and appropriate HMWM resin primer components. Contractor shall not change System Provider during project, without approval from the Engineer.

**QUALIFICATIONS AND SUBMITTALS**

The Contractor shall submit the following requested items and any other relevant documents at least two weeks prior to the PPC Overlay Pre-placement Conference. These submittals are for approval and shall be directed to the Engineer.

- A. Overlay System: The Contractor shall submit two copies of the System Provider's material information, written installation instructions, safety data sheets, and independent test results for approval.
- B. System Provider Qualifications: The Contractor shall install an overlay system with all components provided through a single System Provider with documented experience successfully supplying at least 5 PPC overlay projects of similar size and scope within the past 5 years. The Contractor shall submit documentation of the System Provider's project experience including the following:
  - 1) Project Location
  - 2) Owner Agency
  - 3) Project construction date
  - 4) Overlay quantities
  - 5) Reference name and contact information for owner representative
- C. Contractor Qualifications: The Contractor shall submit documentation of successful projects placing structural concrete bridge decks, modified concrete bridge deck overlays, or PPC overlay systems to finished grade using similar equipment as specified herein within the past 5 years. A minimum of two (2) employees on site must have the equivalent work experience qualifications of the Contractor. The documentation of Contractors qualifications shall include the following:
  - 1) Project Location
  - 2) Owner Agency

- 3) Project construction date
- 4) Overlay quantities
- 5) Reference name and contact information for owner representative

D. System Provider Technical Representative Qualifications: The System Provider Technical Representative shall have a minimum of 5 years of experience with PPC and be completely competent in all aspects of the work, including surface preparation, mixing, placement, curing, and testing of the PPC Overlay System. The Technical Representative shall have experience on a minimum of 5 successful projects of similar size and scope. The Contractor shall submit documentation of the System Provider Technical Representative's experience including the following:

- 1) Years of Experience with PPC
- 2) Project location
- 3) Project construction date
- 4) Overlay quantities
- 5) Reference name and contact information for owner representative

The Technical Representative shall be available on site, for a minimum of three (3) days per project, to give the installer advice and guidance on the installation of PPC. This includes, but not limited to deck concrete surface preparation, PPC application, and PPC cure.

E. Overlay Placement Plan: The Contractor shall submit an Overlay Placement Plan that includes the following:

- 1) Schedule of overlay work and testing for each bridge
- 2) Anticipated concrete deck repair locations and repair method
- 3) Staging plan describing overlay placement sequence including:
  - a) Construction joint locations. Longitudinal construction joints between passes shall be located along the centerline or edge of travel lanes.
  - b) Sequence of placement
  - c) Placement widths
  - d) Anticipated placement lengths
  - e) Placement direction
  - f) Joint locations
  - g) Location of proposed trial overlay(s)
- 4) Description of equipment used for:
  - a) Surface preparation including grinding and shotblasting
  - b) Applying HMWM Primer resin
  - c) Measuring, mixing, placing, and finishing the PPC
  - d) Applying surface finish sand
- 5) Method of protecting and finishing inlets and bridge drains
- 6) Method for isolating expansion joints
- 7) Method for measuring and maintaining overlay thickness and profile
- 8) Cure time for PPC
- 9) Storage and handling of HMWM resin and PPC components
- 10) Procedure for disposal of excess HMWM resin, PPC, and containers
- 11) Procedure for cleanup of mixing and placement equipment

F. Equipment: The Contractor shall submit documentation of current certification that mixing equipment has been calibrated (Caltrans California test CT 109 or similar accepted). The Contractor shall submit a documented history of the use of the placement equipment to successfully place PPC overlays on bridge projects for review and approval by the Engineer.

**MATERIALS**

The PPC shall consist of polyester resin binder and aggregate as specified below. It shall also include a compatible primer which when mixed with other specified ingredients and applied as specified herein, is capable of producing a PPC meeting the requirements of this specification.

- 1) Verification. The Contractor shall submit a Certified Test Report from independent labs for all of the materials associated with the PPC overlay in accordance with this special provision.
- 2) Packaging and Shipment. All components shall be shipped in strong, substantial containers, bearing the manufacturer's label specifying batch/lot number, brand name, and quantity. If bulk resin is to be used, the contractor shall notify the Engineer in writing 10 days prior to the delivery of the bulk resin to the job site. Bulk resin is any resin that is stored in containers in excess of 55 gallons.
- 3) Sampling. NCDOT reserves the right to retain and test samples of components of the PPC Overlay system. This includes requiring submittal of samples prior to the first installation or on-site sampling during construction.

A. Polyester Resin Binder: Polyester resin binder shall have the following properties:

- 1) Be an unsaturated isophthalic polyester-styrene co-polymer. The resin content shall be 12% +/-1% of the weight of the dry aggregate.
- 2) Contain at least 1 percent by weight gamma-methacryloxypropyltrimethoxysilane, an organosilane ester silane coupler.
- 3) Be used with a promoter that is compatible with suitable methyl ethyl ketone peroxide and cumene hydroperoxide initiators.
- 4) Meet the required values for the material properties shown in Table 1, below.

Accelerators or inhibitors may be required to achieve proper setting time of PPC. They shall be used as recommended by the overlay System Provider.

**Table 1**  
**POLYESTER RESIN BINDER PROPERTIES**  
**(Each lot sent to job shall be tested)**

Property	Test Method	Requirement
Viscosity*	ASTM D 2196	75 – 200 cps (RVT No.1 Spindle, 20 RPM at 77 °F)
Specific Gravity*	ASTM D 1475	1.05 to 1.10 at 77 °F
Elongation	ASTM D 638	35 percent, minimum Type I specimen, thickness 0.25 ± 0.03” at Rate = 0.45 inch/minute.
	ASTM D 618	Sample Conditioning: 18/25/50+5/70
Tensile Strength	ASTM D 638	2,500 psi, minimum Type I specimen, thickness 0.25 ± 0.03” at Rate = 0.45 inch/minute.
	ASTM D 618	Sample Conditioning: 18/25/50+5/70
* Test shall be performed before adding initiator.		

B. High Molecular Weight Methacrylate (HMWM) Primer: Primer for the substrate concrete surface shall be a wax-free, low odor, high molecular weight methacrylate primer, and consist

of a resin, initiator, and promoter. The primer shall conform to requirements indicated in Table 2, below, and all components shall be supplied by the System Provider.

Initiator for the methacrylate resin shall consist of a metal drier and peroxide. If supplied separately from the resin, the metal drier shall not be mixed with the peroxide directly; a VIOLENT EXOTHERMIC REACTION will occur. The containers and measuring devices shall not be stored in a manner that allows leakage or spilling to contact the containers or materials of the other.

**Table 2**  
**HIGH MOLECULAR WEIGHT METHACRYLATE RESIN PROPERTIES**  
**(Tested yearly)**

Property	Test Method	Requirement
Viscosity**	ASTM D 2196	25 cps maximum (Brookfield RVT with UL adapter, 50 RPM at 77 °F)
Volatile Content**	ASTM D 2369	30 percent, maximum
Specific Gravity**	ASTM D 1475	0.90 minimum at 77 °F
Flash Point	ASTM D 3278	180 °F minimum
Vapor Pressure**	ASTM D 323	1.0 mm Hg, maximum at 77 °F
PCC Saturated Surface-Dry Bond Strength (Adhesive)	California Test 551, part 5	700 psi, minimum at 24 hours and 70 ± 1°F (with PPC at 12% resin content by weight of the dry aggregate), primed surface
**Test shall be performed before initiator is added		

C. Aggregates: PPC aggregate shall have the following properties:

- 1) No more than 45 percent crushed particles retained on the No. 8 sieve when tested in accordance with AASHTO Test Method T335.
- 2) Fine aggregate consists of natural sand only.
- 3) Weighted-average aggregate absorption of no more than 1.0 percent when tested under AASHTO Test Methods T84 and T85.
- 4) At the time of mixing with resin, have moisture content of not more than one-half of the weighted-average aggregate absorption when tested under AASHTO Test Method T255.
- 5) Moh's hardness of 7 or greater.
- 6) Comply with the requirements for the aggregate gradation indicated in Table 3, below:

**Table 3**  
**AGGREGATE GRADATION**  
**(Tested yearly)**

Sieve Size	Percent Passing
3/8"	100
No. 4	60-85
No. 8	55-65
No. 16	29-50
No. 30	16-36
No. 50	5-20
No. 100	0-7
No. 200	0-3



Sand for abrasive sand finish shall have the following properties:

- 1) Commercial-quality blast sand.
  - 2) Not less than 95 percent pass the No. 8 sieve and not less than 95 percent retained on the No. 20 sieve when tested under AASHTO Test Method T27.
  - 3) Shall be dry at the time of application.
- D. Composite system: The composite PPC system shall have the following properties indicated in Table 4, below:

**Table 4**  
**COMPOSITE PROPERTIES**  
(Tested every 2 years)

Property	Test Method	Requirement
PCC Saturated Surface Dry Bond Strength	CT 551	500 psi minimum at 24 hrs. and 70° F (without primer, at 12% resin content by weight of the dry aggregate, on Saturated Surface Dry Specimen)
Abrasion Resistance	CT 550	<2g weight loss (at 12% resin content by weight of the dry aggregate)
Modulus of Elasticity	ASTM C 469	1,000,000 psi to 2,000,000 psi (at 12% resin content by weight of the dry aggregate)

#### CONSTRUCTION REQUIREMENTS

- A. PPC Overlay Pre-placement Conference: A Pre-placement Conference shall be held before any overlay operations begin. Attendees shall include representatives from all parties involved in the work. If necessary, teleconferencing of attendees may be approved by the Engineer.
- B. Trial Application: Prior to constructing the overlay, one or more trial applications shall be placed on a previously constructed concrete base to demonstrate proper initial set time and the effectiveness of the mixing, placing, and finishing equipment proposed. The set time can be determined as the time elapsed from resin catalyzation until the in-place PPC cannot be deformed by pressing with a finger, indicating the resin binder is no longer in a liquid state. Each trial application shall be the planned paving width, at least 10 feet long, and the same thickness as the specified overlay. Conditions during the construction of the trial application(s) and equipment used shall be similar to those to be used for construction of the overlay. The location of the trial application(s) shall be approved by the Engineer. Trial applications shall be properly disposed of off-site by the Contractor, if removal is necessary.

The number of trial applications required shall be as many as necessary for the Contractor to demonstrate the ability to construct an acceptable trial overlay section and competency to perform the work. However, the installer or proposed equipment/techniques may be rejected if not shown to be acceptable after three (3) trials.

Overlay tensile bond testing shall be performed in accordance with the acceptance testing herein. Vertical axis pull bond tests shall be performed after 24 hours by the Contractor in accordance to ACI 503R-30. At a minimum, 2 pull bond tests shall be performed on each Trial Application. Acceptable test results shall be achieved on a Trial Application before the installation may proceed. Tensile bond testing shall be performed by an independent testing firm and shall be arranged by the Contractor, cost to be included in bid price for *Placing and Finishing PPC Overlay* item.

- C. Equipment: All equipment for cleaning the existing concrete surface and mixing and applying

the overlay system shall be in accordance with the System Provider's recommendations, as approved by the Engineer prior to commencement of any work.

- 1) Surface Preparation Equipment: Provide appropriate scarifying, shotblasting, sandblasting and other equipment to adequately prepare the bridge deck substrate, as required in the Overlay Surface Preparation for Polyester Polymer Concrete special provision.
- 2) Mixing Equipment: A continuous automated mixer shall be used for all PPC overlay applications. The continuous mixer shall:
  - a. Employ an auger screw/chute device capable of sufficiently mixing catalyzed resin with dry aggregate.
  - b. Employ a plural component pumping system capable of handling polyester binder resin and catalyst while maintaining proper ratios to achieve set/cure times within the specified limits. Catalyzed resin shall flow through a static mix tube for sufficient duration to completely mix the liquid system.
  - c. Be equipped with an automatic metering device that measures and records aggregate and resin volumes. Record volumes at least every five minutes, including time and date. Submit recorded volumes at the end of the work shift.
  - d. Have a visible readout gage that displays volumes of aggregate and resin being recorded.
  - e. Produce a satisfactory mix consistently during the entire placement.

A portable mechanical mixer of appropriate size for proposed batches, as recommended by the System Provider and approved by the Engineer, may be used for all PPC patching applications and for smaller area overlay applications if approved by the Engineer.

- 3) Finishing Equipment: Finishing may be accomplished with a Self-Propelled Slip-Form Paving Machine.

#### Self-Propelled Slip-Form Paving Machine

A self-propelled slip-form paving machine, which is modified or specifically built to effectively place the PPC overlay in a manner that meets the objectives and requirements of the project, shall be used for major PPC overlay applications. The paving machine shall:

- a. Employ a vibrating pan to consolidate and finish the PPC.
  - b. Be fitted with hydraulically controlled grade automation to establish the finished profile. The automation shall be fitted with substrate grade averaging devices on both sides of the new placement; the device shall average 15 feet in front and behind the automation sensors; or the sensor shall be constructed to work with string-line control. It is acceptable to match grade when placing lanes adjacent to previously placed PPC.
  - c. Have sufficient engine power and weight to provide adequate vibration of the finishing pan while maintaining consistent forward placement speed.
  - d. Be capable of both forward and reverse motion under its own power.
- D. Concrete Deck Repairs and Surface Preparation: All areas that require removal of existing patches or unsound concrete shall be removed and prepared in accordance with the requirements of the Overlay Surface Preparation for Polyester Polymer Concrete special provision. Placement of concrete deck repair material shall be in accordance with this special provision. Prepare all concrete deck and repaired deck surfaces in accordance with the requirements of the Overlay Surface Preparation for Polyester Polymer Concrete special provision.
  - E. Application of Overlay: Methods indicated in this specification are typical of general installations and may be modified per the System Provider's recommendations as approved by the Engineer. The application of the overlay shall not begin until the concrete deck is

completely surface dry in accordance with ASTM D4263, with a wait time revised from 16 hours to 2 hours, or as directed by the System Provider's Technical Representative. The concrete surface temperature shall be between 40° and 100° F. Night work may be required when temperatures cannot be met during the day.

During overlay application, precaution shall be taken to assure that traffic is protected from rebound, dust, and construction activities. Appropriate shielding shall be provided as required and directed by the Engineer.

During overlay application, the Contractor shall provide suitable coverings (e.g. heavy duty drop cloths) as needed to protect all exposed areas not to receive overlay, such as curbs, sidewalks, parapets, etc. All damage or defacement resulting from this application shall be cleaned and/or repaired to the Engineer's satisfaction at no additional cost.

- 1) HMWM Primer Application: Immediately before placing primer, all exposed surfaces shall be completely dry and blown clean with oil-free compressed air. Exposed surfaces shall be protected from precipitation and heavy dew during and after the application of the primer.

After the exposed surfaces have been prepared and are dry, primer shall be applied in accordance with the System Provider's recommendations. Primer shall be placed within 5 minutes of mixing at approximately 90 ft<sup>2</sup>/ gal or the rate acceptable to the Engineer.

Primer shall be applied by flooding and uniformly spread to completely cover surfaces to receive overlay. Care shall be taken to avoid heavy application that results in excess puddling. Excess material shall be removed or distributed to meet the required application rate. Primer shall be reapplied to any areas that appear dry prior to overlay placement.

Primer shall not be allowed to leak onto areas that have not received surface preparation.

- 2) PPC Application: The PPC shall be applied during the interval between 15 minutes and 2 hours after the primer has been applied. The PPC shall be placed prior to gelling and within 15 minutes following addition of initiator, unless otherwise recommended by the System Provider's Technical Representative.

The polyester resin binder shall be initiated and blended completely. Aggregate shall be added and mixed sufficiently when a portable mechanical mixer is used.

PPC shall have an initial set time of at least 30 minutes and at most 90 minutes. The set time can be determined in the field when the in-place PPC cannot be deformed by pressing with a finger, indicating that the resin binder is no longer in a liquid state. If the initial set is not within 30 to 90 minutes, the material shall be removed and replaced.

The overlay shall be consolidated and finished to the required grade and cross-section using PPC placement equipment as defined herein.

If a vibratory screed is used, prior to placing the PPC, place and fasten screed rails in position to ensure finishing the new surface to the required profile. Do not treat screed rails with parting compound to facilitate their removal. Prior to placing the overlay, attach a filler block to the bottom of the screed and pass it over the overlay area to check the thickness. The filler block thickness shall be equal to the design overlay thickness as shown in the plans. Remove all concrete that the block does not clear.

Place the PPC in one operation. Provide a minimum overlay thickness as shown in the plans.

Although the paver or screed may yield a finished or nearly finished surface, additional

finishing may be necessary. PPC shall be finished, as necessary, through traditional concrete finishing methods, producing a slight resin bleed indicating complete consolidation of aggregates.

Finishing of PPC used as patching of an existing deck surface or overlay shall be completed and finished using traditional concrete hand finishing methods and hand concrete finishing tools. Such patches shall be placed flush with the top of the existing deck surface.

Resin content shall be as specified in the Materials section of this special provision and to yield a PPC consistency that requires surface applied consolidation and finishing to consolidate aggregates and yield a slight sheen of bleed resin on top surface, yet does not yield excess bleed resin.

A surface friction sand finish of at least 2.2 lbs/ yd<sup>2</sup> shall be broadcast onto the glossy surface immediately after sufficient finishing and before resin gelling occurs. To ensure adequate pavement friction, the completed PPC overlay surface shall be free of any smooth or "glassy" areas such as those resulting from insufficient quantities of surface aggregate. Any such surface defects shall be repaired by the Contractor in the manner recommended by the System Provider and approved by the Engineer at no additional cost.

After application of surface friction sand, unless otherwise indicated on the plans, groove the bridge floor in accordance with Article 420-14(B) of the Standard Specifications. Vehicular traffic may travel across a deck surface that has not been grooved; however, the entire deck area shall be grooved after the PPC overlay achieves design strength and no later than seven days after completion of the overlay unless otherwise approved by the Engineer.

All working deck joints shall be extended through the overlay and be sealed according to the details in the plans.

If traffic is to be returned to the site, but the overlay is not completed within the allowable lane closure time and is more than ¾ inch higher in elevation than the adjacent pavement, the PPC overlay edges shall be tapered. Tapered edges transverse to the direction of traffic and on the leading edge of the overlay shall be at a 4:1 (horizontal: vertical) slope. Tapered edges transverse to the direction of traffic and on the trailing edge of the overlay and tapered edges longitudinal to the direction of traffic shall be at a 45 degree slope. Tapers of 45 degrees may remain, and PPC overlay may be placed adjacent. Tapers with a slope gentler than 45 degrees shall be sawcut square to the overlay surface, prior to placing adjacent PPC overlay.

The Contractor shall collect a ticket for each pass or portion of a pass that is provided by each mixer, and ensure that the following information is shown on each ticket:

- a. Project Number
- b. Bridge Number
- c. Date and Time
- d. Location of Placement (Lane and Station Limits or location and length of placement along the length of the bridge)
- e. Aggregate Weight
- f. Polyester Resin Binder Weight

The tickets shall be available on site for Inspection personnel to use in tabulating quantities.

Curing: The Contractor shall allow the overlay to cure sufficiently before subjecting it to loads or traffic of any nature that may damage the overlay. Cure time depends upon the ambient and deck temperatures as well as initiator/accelerator levels.

The overlay shall be considered cured to a traffic ready state when a minimum reading of 25 on a properly calibrated Swiss hammer is achieved. Other rebound hammers may be use as approved by the Engineer.

F. Acceptance Testing: Acceptance of the deck repairs, surface preparation, and PPC overlay will be determined by the Engineer based on vertical axis bond tests, and smoothness quality testing performed by the Engineer, assisted by the Contractor.

- 1) Overlay Direct Tension Bond Testing: Vertical axis pull bond tests shall be performed after 24 hours by the Contractor in accordance to ACI 503R-30. At a minimum, 2 pull bond tests shall be performed on each bridge overlay. For bridges with deck areas greater than 25,000 square feet, additional tests shall be performed at a frequency of one test per 25,000 square feet of additional deck area, rounded up. Additional testing may be required as directed by the Engineer.

The test result shall be the average of the tests for each structure. Test cores shall be drilled a minimum of 0.25" but no greater than 0.50" below the bond line.

The minimum bond strength of the PPC overlay system on normal weight concrete shall be 250 psi. An acceptable test will demonstrate that the overlay bond strength is sufficient by producing a concrete subsurface failure area greater than 50% of the test surface area. The Contractor shall repair all bond test locations with PPC overlay in accordance with this specification.

- 2) Smoothness Quality Testing: As soon as practical after the PPC has hardened sufficiently, test the finished surface with an approved rolling straightedge that is designed, constructed, and adjusted, so that it will accurately indicate or mark all deck areas which deviate from a plane surface by more than 1/8" in 10'. Remove all high areas in the hardened surface in excess of 1/8" in 10' with an approved grinding or cutting machine. Additionally, the final PPC deck surface shall not deviate from the line and elevation indicated on the plans by more than 0.3" over any 50' length. If approved by the Engineer, correct low areas in an acceptable manner.

G. Corrective Work

- 1) Repair of Surface Defects: The repair materials and finishing methods for surface defects in the overlay shall be in accordance to those used for the application of the overlay. All surface defects shall be repaired to the satisfaction of the Engineer before acceptance of the work is made.
- 2) Correction for Smoothness: Areas showing high spots of more than 1/8 inch in 10 feet shall be marked and diamond ground until the high spot does not exceed 1/8 inch in 10 feet. Ground surface may be sawcut grooved to restore the texture if ordered by the Engineer. Areas showing low spots of more than 1/8 inch in 10 feet shall be marked and prepared with shot blasting or sandblasting, primed, and filled with either catalyzed resin and broadcast sand or mixed PPC slurry material. The use of resin or mixed slurry material shall be as recommended by the System Provider and approved by the Engineer.
- 3) Replacement of Defective Overlay: A defective overlay, or portion thereof, resulting in failing overlay pull bond test results shall be removed and replaced at the Contractor's expense. The Contractor shall submit a written corrective work proposal to the Engineer, which shall include the methods and procedures that will be used. The Contractor shall not commence corrective work until the methods and procedures have been approved in writing by the Engineer. The Engineers approval shall not relieve the Contractor of the responsibility of producing work in conformity with the Contract.

- 4) Repair of Cracking: After a one-week cure period, if cracks are in the overlay, the Contractor shall fill the cracks with properly catalyzed and mixed HMWM primer material at his own expense. Care shall be taken to fill the cracks only, and ensure minimal HMWM primer is left on the finished surface of the overlay.

#### **MEASUREMENT AND PAYMENT**

*Concrete Deck Repair for PPC Overlay* will be measured and paid for at the contract unit price bid per square yard and will be full compensation for placement of concrete deck repair material and shall include the cost of labor, tools, equipment and incidentals necessary to complete the work.

*PPC Materials* will be measured as the actual volume of PPC material complete-in-place. The volume shall include material used for overlay, patching of existing unsound concrete deck surface or overlays, and bridge deck concrete repairs as directed by the Engineer. Tickets provided to the project inspector, showing quantities of PPC produced, shall be sufficient to calculate volume of material placed. Materials placed for Trial Overlay shall be included in Pay Quantity if placed and remaining on the bridge deck as part of the permanent overlay. *PPC Materials* will be paid for at the contract unit price per cubic yard and will be full compensation to furnish the PPC material, including HMWM primer, freight to the project site, receiving, storage, and disposal of any unused PPC overlay material. Payment by cubic foot will be based on a 135 lbs/ ft<sup>3</sup> unit weight and quantities recorded by calibrated mixer unit readouts.

*Placing and Finishing PPC Overlay* will be measured and paid for as the quantity of final surface finishing. Payment will be full compensation for all labor, equipment, and all incidentals necessary to complete the PPC overlay placement. Construction and removal (if required) of Trial Overlay, including concrete base surfaces, will not be measured and paid for separately, but shall be included in the work.

Payment will be made under:

#### **Pay Item**

Concrete Deck Repair for PPC Overlay  
PPC Materials  
Placing and Finishing PPC Overlay

#### **Pay Unit**

Square Yard  
Cubic Yard  
Square Yard

#### **BRIDGE JOINT DEMOLITION**

(SPECIAL)

#### **DESCRIPTION**

This provision addresses the removal of existing joint material and adjacent concrete to facilitate the installation of new bridge joints at the locations noted in the contract plans.

#### **EQUIPMENT**

Use the following surface preparation equipment:

- Sawing equipment capable of sawing concrete to a specified depth.
- Power driven hand tools for removal of concrete are required that meet the following requirements:

Pneumatic hammers weighing a nominal 15 lbs (7 kg) or less.

Pneumatic hammer chisel-type bits that do not exceed the diameter of the shaft in width.

- Hand tools such as hammers and chisels for removal of final particles of concrete.

### **REMOVAL AND PREPARATION**

Prior to any construction, take the necessary precautions to ensure debris from joint construction is not allowed to fall below the bridge deck.

Remove existing joint material by methods approved by the Engineer. Provide a 1" deep saw cut around the perimeter of areas noted for bridge deck removal.

Remove by chipping with hand tools concrete adjacent to the joint to the limits shown on the contract plans. Use a small chipping hammer (15 lb. class) to prepare the edges of the repair area to limit micro fractures. In addition, all loose and unsound concrete shall be removed.

In overhangs, removing concrete areas greater than 0.60 ft<sup>2</sup>/ft length of bridge will require overhang support. Submit the overhang support method to the Engineer for approval.

Care shall be taken not to cut, stretch, or damage any exposed reinforcing steel. Dispose of the removed concrete.

If the condition of the concrete is such that deep spalls or sheer faces result, notify the Engineer for the proper course of action.

Clean, repair or replace rusted or loose reinforcing steel. Thoroughly clean the newly exposed surface to be free of all grease, oil, curing compounds, acids, dirt, or loose debris.

### **MEASUREMENT AND PAYMENT**

*Bridge Joint Demolition* will be measured and paid for at the contract unit price bid per square foot and will be full compensation for removal, containment and disposal of existing joint material and concrete and shall include the cost of labor, tools, equipment and incidentals necessary to complete the work.

<b>Pay Item</b>	<b>Pay Unit</b>
Bridge Joint Demolition	Square Feet

### **FOAM JOINT SEALS**

**(SPECIAL)**

#### **1.0 SEALS**

Use preformed seals compatible with concrete and resistant to abrasion, oxidation, oils, gasoline, salt and other materials that are spilled on or applied to the surface. Use a resilient, UV stable, preformed, impermeable, flexible, expansion joint seal. The joint seal shall consist of low-density, closed cell, cross-linked polyethylene non-extrudable, foam. The joint seal shall contain no EVA (Ethylene Vinyl Acetate). Cell generation shall be achieved by being physically blown using nitrogen. No chemical blowing agents shall be used in the cell generation process.

Use seals manufactured with grooves  $1/8'' \pm$  wide by  $1/8'' \pm$  deep and spaced between  $1/4''$  and  $1/2''$  apart along the bond surface running the length of the joint. Use seals with a depth that meets the manufacturer's recommendation, but is not less than 70% of the uncompressed width. Provide a seal designed so that, when compressed, the center portion of the top does not extend upward above the original height of the seal by more than  $1/4''$ . Provide a seal that has a working range of 30% tension and 60% compression and meets the requirements given below.

TEST	TEST METHOD	REQUIREMENT
Tensile strength	ASTM D3575-08, Suffix T	110 – 130 psi
Compression Set	ASTM D1056 Suffix B, 2 hr recovery	10% - 16%
Water Absorption	ASTM D3575	< 0.03 lb/ft <sup>2</sup>
Elongation at Break	ASTM D3575	180% - 210%
Tear Strength	ASTM D624 (D3575-08, Suffix G)	14 – 20 pli
Density	ASTM D3575-08, Suffix W, Method A	1.8 – 2.2 lb/ft <sup>3</sup>
Toxicity	ISO-10993.5	Pass (not cytotoxic)

Have the top of the joint seal clearly shop marked. Inspect the joint seals upon receipt to ensure that the marks are clearly visible before installation.

## 2.0 BONDING ADHESIVE

Use a two component, 100% solid, modified epoxy adhesive supplied by the joint seal manufacturer that meets the requirements given below.

TEST	TEST METHOD	REQUIREMENT
Tensile strength	ASTM D638	3000 psi (min.)
Compressive strength	ASTM D695	7000 psi (min.)
Hardness	Shore D Scale	75-85 psi
Water Absorption	ASTM D570	0.25% by weight max.
Elongation to Break	ASTM D638	5% (max.)
Bond Strength	ASTM C882	2000 psi (min.)

Use an adhesive that is workable to 40°F. When installing in ambient air or surface temperatures below 40°F or for application on moist, difficult to dry concrete surfaces, use an adhesive specified by the manufacturer of the joint seal.

## 3.0 SAWING THE JOINT

The joint opening shall be initially formed to the width shown on the plans including the blockout for the elastomeric concrete.



The elastomeric concrete shall have sufficient time to cure such that no damage can occur to the elastomeric concrete prior to sawing to the final width and depth as specified in the plans.

When sawing the joint to receive the foam seal, always use a rigid guide to control the saw in the desired direction. To control the saw and to produce a straight line as indicated on the plans, anchor and positively connect a template or a track to the bridge deck. Do not saw the joint by visual means such as a chalk line. Fill the holes used for holding the template or track to the deck with an approved, flowable non-shrink, non-metallic grout.

Saw cut to the desired width and depth in one or two passes of the saw by placing and spacing two metal blades on the saw shaft to the desired width for the joint opening.

The desired depth is the depth of the seal plus 1/4" above the top of the seal plus approximately 1" below the bottom of the seal. An irregular bottom of sawed joint is permitted as indicated on the plans. Grind exposed corners on saw cut edges to a 1/4" chamfer.

Saw cut a straight joint, centered over the formed opening and to the desired width specified in the plans. Prevent any chipping or damage to the sawed edges of the joint.

Remove any staining or deposited material resulting from sawing with a wet blade to the satisfaction of the Engineer.

#### **4.0 PREPARATION OF SAWED JOINT FOR SEAL INSTALLATION**

Concrete shall cure a minimum of 24 hours prior to seal installation.

After sawing the joint, the Engineer will thoroughly inspect the sawed joint opening for spalls, popouts, cracks, etc. All necessary repairs will be made by the Contractor prior to blast cleaning and installing the seal.

Clean the joints by sandblasting with clean dry sand immediately before placing the bonding agent. Sandblast the joint opening to provide a firm, clean joint surface free of curing compound, loose material and any foreign matter. Sandblast the joint opening without causing pitting or uneven surfaces. The aggregate in the elastomeric concrete may be exposed after sandblasting.

After blasting, either brush the surface with clean brushes made of hair, bristle or fiber, blow the surface with compressed air, or vacuum the surface until all traces of blast products and abrasives are removed from the surface, pockets, and corners.

If nozzle blasting is used to clean the joint opening, use compressed air that does not contain detrimental amounts of water or oil.

Examine the blast cleaned surface and remove any traces of oil, grease or smudge deposited in the cleaning operations.

Bond the seal to the blast cleaned surface on the same day the surface is blast cleaned.

#### **5.0 SEAL INSTALLATION**

Install the joint seal according to the manufacturer's procedures and recommendations and

as recommended below. Do not install the joint seal if the ambient air or surface temperature is below 45°F. Have a manufacturer's certified trained factory representative present during the installation of the first seal of the project.

Before installing the joint seal, check the uninstalled seal length to insure the seal is the same length as the deck opening. When the joint seal requires splicing, use the heat welding method by placing the joint material ends against a teflon heating iron of 425-475°F for 7 - 10 seconds, then pressing the ends together tightly. Do not test the welding until the material has completely cooled.

Begin installation by protecting the top edges of the concrete deck adjacent to the vertical walls of the joint as a means to minimize clean up. After opening both cans of the bonding agent, stir each can using separate stirring rods for each component to prevent premature curing of the bonding agent. Pour the two components, at the specified mixing ratio, into a clean mixing bucket. Mix the components with a low speed drill (400 rpm max.) until a uniform gray color is achieved without visible marbling. Apply bonding agent to both sides of the elastomeric concrete as well as both sides of the joint seal, making certain to completely fill the grooves with epoxy. With gloved hands, compress the joint seal and with the help of a blunt probe, push the seal into the joint opening until the seal is recessed approximately 1/4" below the surface. When pushing down on the joint seal, apply pressure only in a downward direction. Do not push the joint seal into the joint opening at an angle that would stretch the material. Seals that are stretched during installation shall be removed and rejected. Once work on placing a seal begins, do not stop until it is completed. Clean the excess epoxy from the top of the joint seal immediately with a trowel. Do not use solvents or any cleaners to remove the excess epoxy from the top of the seal. Remove the protective cover at the joint edges and check for any excess epoxy on the surface. Remove excess epoxy with a trowel, the use of solvents or any cleaners will not be allowed.

The installed system shall be watertight and will be monitored until final inspection and approval. Do not place pavement markings on top of foam joint seals.

## **6.0 BASIS OF PAYMENT**

Payment for all foam joint seals will be at the contract unit price per linear foot for "Foam Joint Seals". Prices and payment will be full compensation for furnishing all material, including labor, tools and equipment necessary for installing these units in place and accepted.

## **EXPANSION JOINT SEAL REPAIR**

**(SPECIAL)**

### **1.0 GENERAL**

The work covered by this Special Provision consists of furnishing and installing the expansion joint seals as shown on the contract drawings. All materials, labor, equipment and incidentals necessary for the proper installation of the expansion joint seals are included.

### **2.0 MATERIAL**

Provide expansion joint seals capable of accommodating a total movement measured parallel to

the centerline of the roadway as shown on plans.

Provide an elastomeric component for each expansion joint seal that is a continuous unit for the entire length of the joint. Do not field splice the elastomeric component. Only vulcanized shop splicing of the elastomeric component is permitted. The minimum length of an elastomeric component before shop splicing is 20 feet. However, one piece shorter than 20 feet is permitted. Provide an elastomeric component that is clearly shop marked to indicate the top side and joint location of the elastomeric component. On skewed bridges, or under unsymmetrical conditions, clearly mark the left side of the elastomeric component. Left is defined as being on the left when facing in the direction of increasing station. Inspect the seals upon receipt to ensure that the marks are clearly visible upon installation.

Make sure the convolution of the gland does not project above the top of the hold-down plates when the joint opening is in the most compressed condition. Use either elastic polychloroprene (neoprene) or ethyl propylene diene monomer (EPDM) for the elastomer that meets the following minimum properties:

	ASTM TEST METHOD	REQUIREMENTS
Hardness, Durometer - Shore A	D2240	60 ± 5, Neoprene (upward corrugated shape - fabric reinforced) 75 ± 5, EPDM and Neoprene (upward non-corrugated shape) 80 ± 5, EPDM (upward corrugated shape-fabric reinforced)
Tensile Strength	D412	2000 psi (min.)
Elongation at Break	D412	250% (min.)
Width of Gland in Relaxed Condition	N/A	10" ± 0.25"
Thickness of Upturned portion of gland	N/A	0.25" non-corrugated shape, -0.032" to +0.032"
Thickness of Upturned portion of gland	N/A	0.1875" corrugated shape, -0.032" to +0.032"
Thickness of Flat portion of gland	N/A	0.1563", -0.032" to +0.032"

For fabric reinforced glands, submit one unreinforced sample per lot number, up to 500 feet of Expansion Joint Seal, to the Engineer for testing.

Inspect the condition of the existing hold-down plates for cracks, deformations or other damage that the Engineer might determine necessitates replacement of a hold-down plate. Replacement plates shall conform to AASHTO M270 Grade 36 steel or approved equal.

Only field splice hold-down plates at crown points, at abrupt changes in the deck slab cross slope, and on lane lines. Splicing within travel lanes is not permitted and splicing on edge lines

is not required. Field splice hold-down plates between the edge line and gutter upturn and where necessary for proper installation and alignment is permitted. Show all splice locations on the working drawings for approval. For the location of lane markings at the expansion joint seal, see the Structure plans. At the splice locations, locate the hold-down bolts 3 inches from the end of the hold-down plate. At splice locations where changes in deck slab cross slope occur, cut the ends of hold-down plates parallel to the bridge centerline for skews less than 80° and greater than 100°.

Do not use welded shop splices in hold-down plates.

Replace hold-down bolts with new bolts that conform to ASTM F593 alloy 304 stainless steel. Replace washers with new washers that conform to ASTM F844 except they shall be made from alloy 304 stainless steel.

### 3.0 **SHOP DRAWINGS**

Submit nine sets of working drawings to the Engineer for review, comments and acceptance. Show complete details drawn to scale and include:

- The proposed template details including the makeup of the template.
- The proposed chronology of installation including the sequence and direction of the removal and replacement of the existing gland.
- The proposed method for removing the hold-down plate.

Have someone other than the one who prepares the drawing check all detailed drawings and include the signatures of both the drafter and checker on each sheet of the drawings. The Engineer returns unchecked drawings to the Contractor. Provide all completed drawings well in advance of the scheduled installation time for the expansion joint seal repair.

### 4.0 **INSTALLATION**

#### Expansion Joint Seal Repairs Under Staged Closures

For expansion joint seal repairs that are staged, perform steps 1 through 4 for the initial stage for gland replacement:

1. Loosen the existing bolts and hold down plates and remove the existing gland. Remove the existing neoprene sealant and clean the existing base angle and hold-down plates of oil, grease, and other latents.
2. Lay the new gland on the base angle and field mark the new gland for the bolt holes. Holes in the new gland shall be punched 7/8" in diameter with a circular hand punch.
3. In order to check for proper alignment, place the new gland and hold-down plates on the base angle. Do not apply new neoprene sealant. Bolt the hold-down plates to the base angle with new bolts and washers, but do not tighten. The engineer shall inspect the joint seal gland, plates, and bolts for proper alignment.

4. After inspection, remove the hold-down plates and new gland. Apply new neoprene sealant to the base angle in accordance with the "installation sketch." Place new gland and hold-down plates on the base angle. Bolt the hold-down plates to the base angle assembly and torque the bolts to 88 ft-lbs with a torque wrench. Check the torque after three (3) hours and, if necessary, retighten to 88 ft-lbs. A final check shall be made at seven (7) days. Torque shall not be less than 80 ft-lbs after seven (7) days.

After completion of steps 1 through 4, open to traffic the stage that has had the new gland installed and close to traffic the next adjacent stage requiring a new gland. Continue with steps 1 through 4 for removal of existing gland and placement of a new expansion joint gland.

Proceed similarly for each successive stage. After completion of installation of the joint gland for all stages, traffic may be returned, temporarily, to all stages.

After completion of installation of the new gland for all stages, perform step 5 for each closure stage:

5. After proper torqueing, clean the bolt hole recesses and the recess between the joint seal device and concrete, completely fill these recesses with new neoprene sealant.

Allow sealant applied during step 5 to cure for a minimum of 4 hours before allowing traffic on the bridge. Alternatively, and if the sealant has not cured sufficiently to prevent sealant from adhering to passing traffic, the Contractor may propose a method (broadcast sand or other) to prevent sealant from adhering to passing traffic.

Unless otherwise approved by the Engineer, step 5 shall be completed within 7 days of installation of new gland.

The Engineer shall be notified of any damaged areas, depressions, spalls, cracks, or irregularities of curbs or decks adjacent to the expansion joint. If directed by, the Engineer submit a proposed method of repair and repair material specifications for approval. This work to repair damaged deck or irregularities will be considered extra work.

If the Engineer deems any aspects of the expansion joint seals unacceptable, make necessary corrections.

## **5.0 INSPECTION**

### **Watertight Integrity Test**

- Upon completion of an expansion joint seal, perform a water test on the top surface to detect any leakage. Cover the roadway section of the joint from curb to curb, or barrier rail to barrier rail, with water, either ponded or flowing, not less than 1 inch above the roadway surface at all points. Block sidewalk sections and secure an unnozzled water hose delivering approximately 1 gallon of water per minute to the inside face of the bridge railing, trained in a downward position about 6 inches above the sidewalks, such that there is continuous flow of water across the sidewalk and down the curb face of the joint.
- Maintain the ponding or flowing of water on the roadway and continuous flow across sidewalks and curbs for a period of 2 hours. At the conclusion of the test, the underside of the joint is closely examined for leakage. The expansion joint seal is considered watertight

if no obvious wetness is visible on the Engineer's finger after touching a number of underdeck areas. Damp concrete that does not impart wetness to the finger is not a sign of leakage.

- If the joint system leaks, locate the place(s) of leakage and take any repair measures necessary to stop the leakage at no additional cost to the Department. Use repair measures recommended by the manufacturer and approved by the Engineer prior to beginning corrective work.
- If measures to eliminate leakage are taken, perform a subsequent water integrity test subject to the same conditions as the original test. Subsequent tests carry the same responsibility as the original test and are performed at no extra cost to the Department.

## 6.0 BASIS OF PAYMENT

Basis of payment for all expansion joint seal repair will be at the contract unit price per linear foot for "Expansion Joint Seal Repair" which price and payment will be full compensation for furnishing and installing all material, including any steel accessory plates for sidewalks, medians and rails, any replacement steel hold-down plates, labor, tools, and incidentals necessary for installing the expansion joint seal repair in place and including all materials, labor, tools and incidentals for performing the original watertight integrity test.

## STRIP SEALS

(12-18-12)

### GENERAL

This Special Provision consists of furnishing and installing strip seal expansion joints as shown on the contract drawings and in accordance with this Special Provision, the Standard Specifications and the manufacturer's recommendation. All materials, labor, equipment, and incidentals necessary for the proper installation of the strip seal expansion joints are included.

### MATERIALS

Use AASHTO M270 Grade 36 (250) or Grade 50W (345W) steel for all steel retainer rails. Provide rails that meet the following requirements:

1<sup>7</sup>/<sub>8</sub>" wide by 8" high minimum dimensions

8.5 lbs/ft minimum weight

Only steel retainer rails of one-piece construction are permitted. Steel retainer rails consisting of two or more components welded together to obtain their final cross-sectional shape are not permitted.

Provide 5/8" diameter x 10" long anchor studs welded to retainer rails. Use ASTM A108 Grade 1018 steel for all studs. Type A studs in accordance with ANSI/AWS/AASHTO Bridge Welding Code D1.5 shall be furnished.

Provide 1/2" diameter weep holes in the retainer rails at 2 foot centers to allow bleeding of trapped air and/or water. Do not obstruct the weep holes with falsework.

Use lubricant adhesive conforming to ASTM D4070.

Use a neoprene gland that is an extruded synthetic rubber utilizing virgin polychloroprene as the only polymer. Require the manufacturer to provide Type 4 certification, in accordance with the Standard Specifications, that the gland has been tested for the following properties:

PHYSICAL PROPERTY	TEST METHOD	REQUIREMENTS
Tensile Strength, psi (min.)	ASTM D412	2000
Elongation at break, % (min.)	ASTM D412	250
Hardness, Type A durometer, points	ASTM D2240 Modified	60 ± 10
Oven aging, 70h @ 212°F Tensile strength, % change (max.) Elongation, % change (max.) Hardness, points change (max.)	ASTM D573	-20 -20 0 to +10
Oil Swell, ASTM Oil No. 3, 70h @ 212°F Weight change, % (max.)	ASTM D471	45
Ozone resistance 20% strain, 300 pphm in air 70h @ 104°F	ASTM D1149 Modified	No cracks
Low temperature stiffening, 7 days @ 14°F Hardness, Type A durometer, points change	ASTM D2240	0 to +15
Compression Set, 70h @ 212°F (max.)	ASTM D395 Method B (modified)	40%

Use one continuous neoprene gland for the entire length of the joint. Only vulcanized shop splicing of the gland is permitted. Field splicing of the neoprene gland is not permitted.

### SHOP DRAWINGS

Submit working drawings in accordance with these provisions to the Engineer for review, comments and acceptance. Have someone other than the one who prepares the drawings check all detailed drawings and include the signatures of both the drafter and checker on each sheet of the drawings. The Engineer returns unchecked drawings to the Contractor. Provide all completed drawings well in advance of the scheduled installation time for the strip seal expansion joint.

Show all dimensions, stud anchor locations, welded splice details, splice locations and any other data necessary to fabricate the joint on the shop drawings. Draw all details to scale. Identify, in detail, welding procedures to be performed in fabricating the joint. As a minimum, also show the following on the drawings:

- The method of supporting retainer rails horizontally and vertically during joint installation and placement of concrete to ensure stability and proper alignment. Place supports near field splices of retainer rails to ensure that splices are straight and even.

- A section detail through the joint showing horizontal offset dimensions of the rails from the centerline joint. This detail is required when the vertical face of the joint opening is not perpendicular to the roadway surface (e.g. when the roadway grade is significant).
- Details of the shipping device for retainer rails.

**SHIPMENT**

Bolt the steel retainer rails together in the shop to form matching pairs. Clearly mark each pair to identify where they are to be placed. Ship the neoprene gland concurrently with the steel retainer rails and clearly mark them to identify where they are to be placed.

**INSTALLATION**

Follow the manufacturer's recommended installation procedures. Have a manufacturer's representative present during installation of the joint.

**INSPECTION**

When concrete is cast, use a non-aluminum, 10 foot, true to line straight edge to check and grade the top of the slab on each side of the joint to ensure smooth transition between spans.

The Engineer inspects the joint system for proper alignment and proper stud placement and attachment. If any aspect of the strip seal expansion joint is deemed unacceptable, make the necessary corrections.

**Watertight Integrity Test**

- Upon completion of each strip seal expansion joint, perform a water test on the top surface to detect any leakage. Cover the roadway section of the joint from curb to curb, or barrier rail to barrier rail, with water, either ponded or flowing, not less than 1 inch above the roadway surface at all points. Block sidewalk sections and secure an unnozzled water hose delivering approximately 1 gallon of water per minute to the inside face of the bridge railing, trained in a downward position about 6 inches above the sidewalk, such that there is continuous flow of water across the sidewalk and down the curb face of the joint.
- Maintain the ponding or flowing of water on the roadway and continuous flow across sidewalks and curbs for a period of 5 hours. At the conclusion of the test, the underside of the joint is closely examined for leakage. The strip seal expansion joint is considered watertight if no obvious wetness is visible on the Engineer's finger after touching a number of underdeck areas. Damp concrete that does not impart wetness to the finger is not considered a sign of leakage.
- If the joint system leaks, locate the place(s) of leakage and take any repair measures necessary to stop the leakage at no additional cost to the Department. Use repair measures recommended by the manufacturer and approved by the Engineer prior to beginning corrective work.
- If measures to eliminate leakage are taken, perform a subsequent water integrity test subject to the same conditions as the original test. Subsequent tests carry the same responsibility as the original test and are performed at no additional cost to the Department.

**BASIS OF PAYMENT**

Basis of payment for all strip seals will be at the lump sum contract price for "Strip Seals" which price and payment will be full compensation for furnishing all material, including any steel accessory plates



for sidewalks, medians and rails, labor, tools, and incidentals necessary for installing the strip seal in place and including all materials, labor, tools and incidentals for performing the original watertight integrity test.

### **PARTIAL REMOVAL OF EXISTING STRUCTURE**

**(SPECIAL)**

The Contractor shall remove existing modular joint hardware and concrete necessary to replace expansion joint at Bent 1 of Bridge No.113 and Bridge No.115 as detailed in the plans. Care shall be taken so as not to damage existing reinforcing steel and existing concrete girders. The Contractor is liable for any damage caused to structure elements that are to be retained.

During removal, the Contractor shall ensure the safety of vehicular traffic. Removed materials shall become the possession of the Contractor. The Contractor is responsible for disposing of all materials in an acceptable manner.

All work covered by this Special Provision shall be paid for at the contract lump sum price for "Partial Removal of Existing Structure". The above price and payment will be full compensation for furnishing all labor, equipment, materials, and any incidentals necessary to complete this work.

Payment will be made under:

**Pay Item Pay**

**Unit**

Partial Removal of Existing Structure

Lump Sum

### **ADDITIONAL REINFORCING STEEL**

**(SPECIAL)**

The reinforcement in the vicinity of the existing modular expansion joint of Bridge No. 113 and Bridge No. 115 is not known for certain. The Contractor shall supply and install additional epoxy coated reinforcing steel in under-reinforced regions if needed. After removal of the existing joint, the Contractor along with the Engineer shall determine the condition and quantity of reinforcing steel. If required by the Engineer, the Contractor shall shop or field bend and install needed bars prior to casting of proposed concrete.

The need for *Additional Reinforcing Steel* is uncertain. The Contractor shall have no claim against the Department for over or under-runs of this pay item. This item is considered a minor pay item as explained in Section 104-5 of the Standard Specifications. In the event the amount of *Additional Reinforcing Steel* exceeds 100% more than the bid amount, the price bid by the Contractor shall remain valid. No price increase will be awarded based upon final contract quantity.

### **MEASUREMENT AND PAYMENT**

*Additional Reinforcing Steel* will be measured and paid for at the contract unit price bid per pound and will be full compensation for material, fabrication and installation of epoxy coated reinforcing steel and shall include the cost of labor, tools, equipment and incidentals necessary to complete the work.

Payment will be made under:

**Pay Item Pay**

**Unit**

Additional Reinforcing Steel

Pounds

Line #	Item Number	Sec #	Description	Quantity	Unit Cost	Amount
<b>ROADWAY ITEMS</b>						
0001	0000100000-N	800	MOBILIZATION	Lump Sum	L.S.	
0002	0036000000-E	225	UNDERCUT EXCAVATION	120 CY		
0003	0196000000-E	270	GEOTEXTILE FOR SOIL STABILIZATION	385 SY		
0004	0245000000-E	SP	GENERIC GRADING ITEM FOAM INSTALLATION SOIL STABILIZATION	2,085 GAL		
0005	1735000000-E	723	REPAIR OF JOINTED CONCRETE PAVEMENT SLABS	540 SY		
0006	1736000000-E	723	SELECT MATERIAL, CLASS IV	195 TON		
0007	1737000000-E	723	PATCHING CONCRETE PAVEMENT SPALLS	205 SF		
0008	1881000000-E	SP	GENERIC PAVING ITEM JOINT CONSTRUCTION, REPAIR AND SEALING	713,000 LF		
0009	1891000000-E	SP	GENERIC PAVING ITEM DIAMOND GRINDING PCC PAVEMENT	580,000 SY		
0010	2762000000-E	SP	GENERIC PAVING ITEM SLAB LEVELING, UNDERSEALING AND VOID FILLING	3,750 LB		
0011	4400000000-E	1110	WORK ZONE SIGNS (STATIONARY)	824 SF		
0012	4424000000-N	SP	WORK ZONE PRESENCE LIGHTING	12 EA		
0013	4434000000-N	SP	SEQUENTIAL FLASHING WARNING LIGHTS	24 EA		
0014	4510000000-N	1190	LAW ENFORCEMENT	750 HR		
0015	4600000000-N	SP	GENERIC TRAFFIC CONTROL ITEM LANE CLOSURE	60 EA		
0016	4600000000-N	SP	GENERIC TRAFFIC CONTROL ITEM RAMP/LOOP CLOSURE	30 EA		
0017	4726100000-E	1205	HEATED-IN-PLACE THERMOPLASTIC PAVEMENT MARKING CHARACTER (120 MILS)	88 EA		

County : Mecklenburg

Line #	Item Number	Sec #	Description	Quantity	Unit Cost	Amount
0018	4726110000-E	1205	HEATED-IN-PLACE THERMOPLASTIC PAVEMENT MARKING SYMBOL (90 MILS)	55 EA		
0019	4810000000-E	1205	PAINT PAVEMENT MARKING LINES (4")	228,775 LF		
0020	4820000000-E	1205	PAINT PAVEMENT MARKING LINES (8")	19,000 LF		
0021	4845000000-N	1205	PAINT PAVEMENT MARKING SYMBOL	55 EA		
0022	4847030000-E	1205	POLYUREA PAVEMENT MARKING LINES (6", 20 MILS)	182,700 LF		
0023	4847070000-E	1205	POLYUREA PAVEMENT MARKING LINES (12", 20 MILS)	19,000 LF		
0024	4850000000-E	1205	REMOVAL OF PAVEMENT MARKING LINES (4")	228,775 LF		
0025	4860000000-E	1205	REMOVAL OF PAVEMENT MARKING LINES (8")	1,900 LF		
0026	4875000000-N	1205	REMOVAL OF PAVEMENT MARKING SYMBOLS & CHARACTERS	55 EA		
0027	4890000000-E	SP	GENERIC PAVEMENT MARKING ITEM COLD APPLIED PLASTIC PAVEMENT MARKING LINES, TYPE II (9")	61,700 LF		
0028	4895000000-N	SP	GENERIC PAVEMENT MARKING ITEM REMOVE AND REPLACE SNOWPLOW-ABLE PAVEMENT MARKERS	5,720 EA		
0029	4905000000-N	1253	SNOWPLOWABLE PAVEMENT MARKERS	70 EA		
0030	5255000000-N	1413	PORTABLE LIGHTING	Lump Sum	L.S.	
0031	6000000000-E	1605	TEMPORARY SILT FENCE	2,500 LF		
0032	6071010000-E	SP	WATTLE	2,000 LF		

County : Mecklenburg

Line #	Item Number	Sec #	Description	Quantity	Unit Cost	Amount
<b>STRUCTURE ITEMS</b>						
0033	8161000000-E	420	GROOVING BRIDGE FLOORS	120,541	SF	
0034	8217000000-E	425	REINFORCING STEEL (BRIDGE)	1,348	LB	
0035	8224000000-E	425	EPOXY COATED REINFORCING STEEL (BRIDGE)	5,433	LB	
0036	8559000000-E	SP	CLASS II, SURFACE PREPARATION	4	SY	
0037	8566000000-E	SP	CLASS III, SURFACE PREPARATION	82.3	SY	
0038	8699000000-N	SP	STRIP SEALS	Lump Sum	L.S.	
0039	8860000000-N	SP	GENERIC STRUCTURE ITEM PARTIAL REMOVAL OF EXISTING STRUCTURE	Lump Sum	L.S.	
0040	8860000000-N	SP	GENERIC STRUCTURE ITEM VOLUMETRIC MIXER	Lump Sum	L.S.	
0041	8867000000-E	SP	GENERIC STRUCTURE ITEM EXPANSION JOINT SEAL REPAIR	410	LF	
0042	8867000000-E	SP	GENERIC STRUCTURE ITEM FOAM JOINT SEALS	719	LF	
0043	8881000000-E	SP	GENERIC STRUCTURE ITEM POLYESTER POLYMER CONCRETE MATERIALS	432.7	CY	
0044	8882000000-E	SP	GENERIC STRUCTURE ITEM CONCRETE FOR DECK REPAIR	1,442.3	CF	
0045	8889000000-E	SP	GENERIC STRUCTURE ITEM ADDITIONAL REINFORCING STEEL	1,200	LB	
0046	8892000000-E	SP	GENERIC STRUCTURE ITEM BRIDGE JOINT DEMOLITION	73.8	SF	
0047	8893000000-E	SP	GENERIC STRUCTURE ITEM CONCRETE DECK REPAIR FOR POLYESTER POLYMER CONC OVERLAY	4	SY	
0048	8893000000-E	SP	GENERIC STRUCTURE ITEM PLACING & FINISHING POLYESTER POLYMER CONCRETE OVERLAY	14,139	SY	

County : Mecklenburg

Line #	Item Number	Sec #	Description	Quantity	Unit Cost	Amount
0049	8893000000-E	SP	GENERIC STRUCTURE ITEM SCARIFYING BRIDGE DECK	14,139 SY		
-----						
0050	8893000000-E	SP	GENERIC STRUCTURE ITEM SHOTBLASTING BRIDGE DECK	14,139 SY		
-----						
<b>1522/Feb01/Q2228485.1/D276405420000/E50</b>			<b>Total Amount Of Bid For Entire Project :</b>			

DBE GOAL SET: 10.00%  
DBE GOAL OBT: 10.05%

Vendor 1 of 2: CROWDER CONSTRUCTION COMPANY (3685)  
Call Order 014 (Proposal: C204116)

**Bid Information**

---

<b>Proposal County:</b> MECKLENBURG	<b>Bid Checksum:</b> 368170C4
<b>Vendor Address:</b> PO Box 30007 Charlotte , NC , 28230	<b>Bid Total:</b> \$10,608,928.84
<b>Signature Check:</b> George_F_Ellis_3685	<b>Items Total:</b> \$10,608,928.84
<b>Time Bid Received:</b> March 20, 2018 01:54 PM	<b>Time Total:</b> \$0.00
<b>Amendment Count:</b> 0	

**Bidding Errors:**  
None.

Vendor 1 of 2: CROWDER CONSTRUCTION COMPANY (3685)  
Call Order 014 (Proposal: C204116)

Bid Bond Information

---

<b>Projects:</b>	<b>Bond Maximum:</b>
<b>Counties:</b>	<b>State of Incorporation:</b>
<b>Bond ID:</b> SNC18545465	<b>Agency Execution Date:</b> 3/15/2018 11
<b>Paid by Check:</b> No	<b>Surety Name:</b> surety2000
<b>Bond Percent:</b> 5%	<b>Bond Agency Name:</b> Liberty Mutual Insurance Company

Bidder 1 of 2

Vendor 3685's Bid Information for Call 014, Letting L180320, 03/20/18

Crowder Construction Company (3685)  
Call Order 014 (Proposal ID C204116)

LIST OF DBE PARTICIPANTS

VENDOR NUMBER	DBE NAME ADDRESS	WORK CODE TYPE OF WORK	CERT TYPE AMOUNT	
WB 7553	INTERSTATE SEALANT & CONCRETE I 108 A WILMONT DRIVE , WAUKESHA, WI 53189		Sub 1,066,441.00	COMMITTED
			TOTAL: \$1,066,441.00	
			10.05%	

Vendor 3685's Bid Information for Call 014, Letting L180320, 03/20/18

Crowder Construction Company (3685)  
Call Order 014 (Proposal ID C204116)

Miscellaneous Data Info - Contractor Responses:  
=====

NON-COLLUSION AND DEBARMENT CERTIFICATION

Explanation of the prospective bidder that is unable to certify to any of the statements in this certification:

Explanation:  
NOT ANSWERED  
NOT ANSWERED  
NOT ANSWERED  
NOT ANSWERED

AWARD LIMITS ON MULTIPLE PROJECTS

By answering YES to this statement, the bidder acknowledges that they are using the award limits on multiple projects. No

It is the desire of the Bidder to be awarded contracts, the value of which will not exceed a total of NOT ANSWERED for those projects indicated herein, for which bids will be opened on (MM/DD/YY)

The Award Limits shall apply to the following projects:

Contract Number	County
NOT ANSWERED	
NOT ANSWERED	
NOT ANSWERED	
NOT ANSWERED	
NOT ANSWERED	
NOT ANSWERED	

Bid Bond Data Info - Contractor Responses:  
=====

BondID: SNC18545465  
Surety Registry Agency: surety2000  
Verified?: Yes



Bidder 1 of 2

Surety Agency: Liberty Mutual Insurance Company  
Bond Execution Date: 3/15/2018 11  
Bond Amount: \$530,446.44 (Five Percent of Bid)

Dept of Transportation

Revised:

Contract ID: C204116

Project(s): NHPIM-0085(037)

Letting Date: 03-20-18 Call Order: 014

Bidder: 3685 - Crowder Construction Company

Line No.	Item Description	Approx. Quantity and Units	Unit Price Dollars   Cts	Bid Amount Dollars   Ct
Section 0001 ROADWAY ITEMS				
Alt Group				
0001	0000100000-N MOBILIZATION	LUMP	LUMP	530,446.44
0002	0036000000-E UNDERCUT EXCAVATION	120.000 CY	64.00000	7,680.00
0003	0196000000-E GEOTEXTILE FOR SOIL STABILIZATION	385.000 SY	2.70000	1,039.50
0004	0245000000-E GENERIC GRADING ITEM FOAM INSTALLATION SOIL STABILIZATION	2,085.000 GAL	69.00000	143,865.00
0005	1735000000-E REPAIR OF JOINTED CONCRETE PAVEMENT SLABS	540.000 SY	860.00000	464,400.00
0006	1736000000-E SELECT MATERIAL, CLASS IV	195.000 TON	69.00000	13,455.00
0007	1737000000-E PATCHING CONCRETE PAVEMENT SPALLS	205.000 SF	338.00000	69,290.00
0008	1881000000-E GENERIC PAVING ITEM JOINT CONSTRUCTION, REPAIR AND SEALING	713,000.000 LF	2.60000	1,853,800.00
0009	1891000000-E GENERIC PAVING ITEM DIAMOND GRINDING PCC PAVEMENT	580,000.000 SY	4.90000	2,842,000.00
0010	2762000000-E GENERIC PAVING ITEM SLAB LEVELING, UNDERSEALING AND VOID FILLING	3,750.000 LB	6.25000	23,437.50

Dept of Transportation

Revised:

Contract ID: C204116

Project(s): NHPIM-0085(037)

Letting Date: 03-20-18 Call Order: 014

Bidder: 3685 - Crowder Construction Company

Line No.	Item Description	Approx. Quantity and Units	Unit Price Dollars   Cts	Bid Amount Dollars   Ct
0011	4400000000-E WORK ZONE SIGNS (STATIONARY)	824.000	5.85000	4,820.40
		SF		
0012	4424000000-N WORK ZONE PRESENCE LIGHTING	12.000	10,000.00000	120,000.00
		EA		
0013	4434000000-N SEQUENTIAL FLASHING WARNING LIGHTS	24.000	130.00000	3,120.00
		EA		
0014	4510000000-N LAW ENFORCEMENT	750.000	45.00000	33,750.00
		HR		
0015	4600000000-N GENERIC TRAFFIC CONTROL ITEM LANE CLOSURE	60.000	4,000.00000	240,000.00
		EA		
0016	4600000000-N GENERIC TRAFFIC CONTROL ITEM RAMP/LOOP CLOSURE	30.000	2,100.00000	63,000.00
		EA		
0017	4726100000-E HEATED-IN-P LACE THERMOPLASTIC PAVEMENT MARKING CHARACTER (120 MILS)	88.000	200.00000	17,600.00
		EA		
0018	4726110000-E HEATED-IN-P LACE THERMOPLASTIC PAVEMENT MARKING SYMBOL (90 MILS)	55.000	1,000.00000	55,000.00
		EA		
0019	4810000000-E PAINT PAVEMENT MARKING LINES (4")	228,775.000	0.30000	68,632.50
		LF		
0020	4820000000-E PAINT PAVEMENT MARKING LINES (8")	19,000.000	0.60000	11,400.00
		LF		
0021	4845000000-N PAINT PAVEMENT MARKING SYMBOL	55.000	65.00000	3,575.00
		EA		

Dept of Transportation

Revised:

Contract ID: C204116

Project(s): NHPIM-0085(037)

Letting Date: 03-20-18 Call Order: 014

Bidder: 3685 - Crowder Construction Company

Line No.	Item Description	Approx. Quantity and Units	Unit Price Dollars   Cts	Bid Amount Dollars   Ct
0022	4847030000-E POLYUREA PAVEMENT MARKING LINES (6", 20 MILS)	182,700.000 LF	1.00000	182,700.00
0023	4847070000-E POLYUREA PAVEMENT MARKING LINES (12", 20 MILS)	19,000.000 LF	2.00000	38,000.00
0024	4850000000-E REMOVAL OF PAVEMENT MARKING LINES (4")	228,775.000 LF	0.45000	102,948.75
0025	4860000000-E REMOVAL OF PAVEMENT MARKING LINES (8")	1,900.000 LF	2.00000	3,800.00
0026	4875000000-N REMOVAL OF PAVEMENT MARKING SYMBOLS & CHARACTERS	55.000 EA	100.00000	5,500.00
0027	4890000000-E GENERIC PAVEMENT MARKING ITEM COLD APPLIED PLASTIC PAVEMENT MARKING LINES, TYPE II (9")	61,700.000 LF	7.50000	462,750.00
0028	4895000000-N GENERIC PAVEMENT MARKING ITEM REMOVE AND REPLACE SNOWPLOW- ABLE PAVEMENT MARKERS	5,720.000 EA	75.00000	429,000.00
0029	4905000000-N SNOWPLOWABLE PAVEMENT MARKERS	70.000 EA	31.00000	2,170.00
0030	5255000000-N PORTABLE LIGHTING	LUMP	LUMP	177,000.00
0031	6000000000-E TEMPORARY SILT FENCE	2,500.000 LF	3.00000	7,500.00
0032	6071010000-E WATTLE	2,000.000 LF	10.00000	20,000.00

Dept of Transportation

Revised:

Contract ID: C204116

Project(s): NHPIM-0085(037)

Letting Date: 03-20-18 Call Order: 014

Bidder: 3685 - Crowder Construction Company

Line No.	Item Description	Approx. Quantity and Units	Unit Price Dollars   Cts	Bid Amount Dollars   Ct
				8,001,680.09
Section 0004 STRUCTURE ITEMS				
Alt Group				
0033	8161000000-E GROOVING BRIDGE FLOORS	120,541.000 SF	0.55000	66,297.55
0034	8217000000-E REINFORCING STEEL (BRIDGE)	1,348.000 LB	3.00000	4,044.00
0035	8224000000-E EPOXY COATED REINFORCING STEEL (BRIDGE)	5,433.000 LB	3.20000	17,385.60
0036	8559000000-E CLASS II, SURFACE PREPARATION	4.000 SY	1,000.00000	4,000.00
0037	8566000000-E CLASS III, SURFACE PREPARATION	82.300 SY	2,000.00000	164,600.00
0038	8699000000-N STRIP SEALS	LUMP	LUMP	20,000.00
0039	8860000000-N GENERIC STRUCTURE ITEM PARTIAL REMOVAL OF EXISTING STRUCTURE	LUMP	LUMP	47,000.00
0040	8860000000-N GENERIC STRUCTURE ITEM VOLUMETRIC MIXER	LUMP	LUMP	5,000.00
0041	8867000000-E GENERIC STRUCTURE ITEM EXPANSION JOINT SEAL REPAIR	410.000 LF	150.00000	61,500.00
0042	8867000000-E GENERIC STRUCTURE ITEM FOAM JOINT SEALS	719.000 LF	170.00000	122,230.00

Dept of Transportation

Revised:

Contract ID: C204116

Project(s): NHPIM-0085(037)

Letting Date: 03-20-18 Call Order: 014

Bidder: 3685 - Crowder Construction Company

Line No.	Item Description	Approx. Quantity and Units	Unit Price Dollars   Cts	Bid Amount Dollars   Ct
0043	8881000000-E GENERIC STRUCTURE ITEM POLYESTER POLYMER CONCRETE MATERIALS	432.700 CY	3,000.00000	1,298,100.00
0044	8882000000-E GENERIC STRUCTURE ITEM CONCRETE FOR DECK REPAIR	1,442.300 CF	89.00000	128,364.70
0045	8889000000-E GENERIC STRUCTURE ITEM ADDITIONAL REINFORCING STEEL	1,200.000 LB	2.00000	2,400.00
0046	8892000000-E GENERIC STRUCTURE ITEM BRIDGE JOINT DEMOLITION	73.800 SF	93.00000	6,863.40
0047	8893000000-E GENERIC STRUCTURE ITEM CONCRETE DECK REPAIR FOR POLYESTER POLYMER CONC OVERLAY	4.000 SY	500.00000	2,000.00
0048	8893000000-E GENERIC STRUCTURE ITEM PLACING & FINISHING POLYESTER POLYMER CONCRETE OVERLAY	14,139.000 SY	26.00000	367,614.00
0049	8893000000-E GENERIC STRUCTURE ITEM SCARIFYING BRIDGE DECK	14,139.000 SY	17.00000	240,363.00
0050	8893000000-E GENERIC STRUCTURE ITEM SHOTBLASTING BRIDGE DECK	14,139.000 SY	3.50000	49,486.50
	Section 0004 Total			2,607,248.75
	Bid Total			10,608,928.84

NON-COLLUSION AND DEBARMENT CERTIFICATION

The bidder certifies that neither he, nor any official, agent or employee of the bidder has entered into any agreement, participated in any collusion, or otherwise taken any action which is in restraint of free competitive bidding in connection with this bid, and that the bidder intends to do the work with its own bonafide employees or subcontractors and is not bidding for the benefit of another contractor. In addition, submitting this electronic bid constitutes the bidder's certification of Status under penalty of perjury under the laws of the United States and in accordance with the Debarment Certification on file with the Department.

By submitting this bid, the bidder certifies to the best of his knowledge and belief that he and his principals:

- a. Are not presently debarred, suspended, proposed for debarment, declared ineligible, or voluntarily excluded from covered transactions by any Federal department or agency;
- b. Have not within a three-year period preceding this proposal been convicted of or had a civil judgment rendered against them for commission of fraud or a criminal offense in connection with obtaining, attempting to obtain, or performing a public (Federal, State or local) transaction or contract under a public transaction; violation of Federal or State antitrust statutes or commission of embezzlement, theft, forgery, bribery, falsification or destruction of records; making false statements; or receiving stolen property;
- c. Are not presently indicted for or otherwise criminally or civilly charged by a governmental entity (Federal, State or local) with commission of any of the offenses enumerated in paragraph b. of this certification; and
- d. Have not within a three-year period preceding this proposal had one or more public transactions (Federal, State or local) terminated for cause or default.

Where the prospective bidder is unable to certify to any of the statements in this certification, the bidder shall submit an explanation in the blanks provided herein. The explanation will not necessarily result in denial of participation in a contract.

Explanation:  
NOT ANSWERED  
NOT ANSWERED  
NOT ANSWERED  
NOT ANSWERED

If the prequalified bidder's status changes, he shall immediately submit a new fully executed non-collusion affidavit and debarment certification with an explanation of the change to the Contract Office prior to submitting the bid.

Failure to furnish a certification or an explanation will be grounds for rejection of a bid

AWARD LIMITS ON MULTIPLE PROJECTS

By answering YES to this statement, the bidder acknowledges that they are using the award limits on multiple projects. No

A bidder who desires to bid on more than one project on which bids are to be opened on the same date, and who also desires to avoid receiving an award of more projects than he is equipped to handle, may bid on any number of projects but may limit the total amount of work awarded to him on selected projects by completing the AWARD LIMITS ON MULTIPLE PROJECTS.

The Award Limits on Multiple Projects must be filled in on each project bid for which the Bidder desires protection.

It is the desire of the Bidder to be awarded contracts, the value of which will not exceed a total of NOT ANSWERED for those projects indicated herein, for which bids will be opened on (MM/DD/YY)

The Award Limits shall apply to the following projects:

Contract Number	County
NOT ANSWERED	
NOT ANSWERED	
NOT ANSWERED	
NOT ANSWERED	
NOT ANSWERED	
NOT ANSWERED	

It is agreed that if I am (we are) the low Bidder(s) on indicated projects, the total value of which is more than the above stipulated award limits, the Board of Transportation will award me (us) projects from among those indicated that have a total value not to exceed the award limit and will result in the lowest total bids to the Department of Transportation.



PROPOSAL: C204116  
 LETTING: L180320 CALL: 014  
 VENDOR: 3685 Crowder Construction Company

-----  
 LINE ITEM                    ITEM                    UNIT SUBCONTRACTOR    SUBCONTRACTOR    EXTENDED  
 NO.    NO.                    DESC.                    TYPE QUANTITY        UNIT PRICE        AMOUNT  
 -----

DBE SUBCONTRACTOR: 7553 INTERSTATE SEALANT & CONCRETE INC  
 Will Use Quote: Yes

0008	1881000000-E	GENERIC PAVI LF	535900.000	1.99000	1066441.00
					-----
		DBE COMMITMENT TOTAL FOR SUBCONTRACTOR:			1,066,441.00
		DBE COMMITMENT TOTAL FOR VENDOR (SubContractor )			1,066,4

TOTAL DBE COMMITMENT FOR VENDOR:                    Entered:    10.05% or    1066441.00  
    Required:    10.00% or    1060892.88  
    <GOAL MET>

THIS PROPOSAL CONTAINS THE FOLLOWING ERRORS/WARNINGS (IF ANY)

This Bid contains 0 amendment files

Electronic Bid Submission

By submitting this bid electronically, I hereby acknowledge that all requirements included in the hard copy proposal, addendum, amendments, plans, standard specifications, supplemental specifications and special provisions are part of the bid and contract. Further, I acknowledge that I have read, understand, accept, acknowledge and agree to comply with all statements in this electronic bid.

I Hereby certify that I have the authority to submit this bid.

Signature

Agency

Date

-----  
-----  
-----

Line #	ItemNumber	Sec #	Description	Quantity Unit	Unit Bid Price	Amount Bid
<b>ROADWAY ITEMS</b>						
0001	0000100000-N	800	MOBILIZATION	Lump Sum LS	530,446.44	530,446.44
0002	0036000000-E	225	UNDERCUT EXCAVATION	120 CY	64.00	7,680.00
0003	0196000000-E	270	GEOTEXTILE FOR SOIL STABILIZATION	385 SY	2.70	1,039.50
0004	0245000000-E	SP	GENERIC GRADING ITEM FOAM INSTALLATION SOIL STABILIZATION	2,085 GAL	69.00	143,865.00
0005	1735000000-E	723	REPAIR OF JOINTED CONCRETE PAVEMENT SLABS	540 SY	860.00	464,400.00
0006	1736000000-E	723	SELECT MATERIAL, CLASS IV	195 TON	69.00	13,455.00
0007	1737000000-E	723	PATCHING CONCRETE PAVEMENT SPALLS	205 SF	338.00	69,290.00
0008	1881000000-E	SP	GENERIC PAVING ITEM JOINT CONSTRUCTION, REPAIR AND SEALING	713,000 LF	2.60	1,853,800.00
0009	1891000000-E	SP	GENERIC PAVING ITEM DIAMOND GRINDING PCC PAVEMENT	580,000 SY	4.90	2,842,000.00
0010	2762000000-E	SP	GENERIC PAVING ITEM SLAB LEVELING, UNDERSEALING AND VOID FILLING	3,750 LB	6.25	23,437.50
0011	4400000000-E	1110	WORK ZONE SIGNS (STATIONARY)	824 SF	5.85	4,820.40
0012	4424000000-N	SP	WORK ZONE PRESENCE LIGHTING	12 EA	10,000.00	120,000.00
0013	4434000000-N	SP	SEQUENTIAL FLASHING WARNING LIGHTS	24 EA	130.00	3,120.00
0014	4510000000-N	1190	LAW ENFORCEMENT	750 HR	45.00	33,750.00
0015	4600000000-N	SP	GENERIC TRAFFIC CONTROL ITEM LANE CLOSURE	60 EA	4,000.00	240,000.00
0016	4600000000-N	SP	GENERIC TRAFFIC CONTROL ITEM RAMP/LOOP CLOSURE	30 EA	2,100.00	63,000.00
0017	4726100000-E	1205	HEATED-IN-PLACE THERMOPLASTIC PAVEMENT MARKING CHARACTER (120 MILS)	88 EA	200.00	17,600.00

## Contract Item Sheets For C204116

Line #	ItemNumber	Sec #	Description	Quantity Unit	Unit Bid Price	Amount Bid
0018	4726110000-E	1205	HEATED-IN-PLACE THERMOPLASTIC PAVEMENT MARKING SYMBOL (90 MILS)	55 EA	1,000.00	55,000.00
0019	4810000000-E	1205	PAINT PAVEMENT MARKING LINES (4")	228,775 LF	0.30	68,632.50
0020	4820000000-E	1205	PAINT PAVEMENT MARKING LINES (8")	19,000 LF	0.60	11,400.00
0021	4845000000-N	1205	PAINT PAVEMENT MARKING SYMBOL	55 EA	65.00	3,575.00
0022	4847030000-E	1205	POLYUREA PAVEMENT MARKING LINES (6", 20 MILS)	182,700 LF	1.00	182,700.00
0023	4847070000-E	1205	POLYUREA PAVEMENT MARKING LINES (12", 20 MILS)	19,000 LF	2.00	38,000.00
0024	4850000000-E	1205	REMOVAL OF PAVEMENT MARKING LINES (4")	228,775 LF	0.45	102,948.75
0025	4860000000-E	1205	REMOVAL OF PAVEMENT MARKING LINES (8")	1,900 LF	2.00	3,800.00
0026	4875000000-N	1205	REMOVAL OF PAVEMENT MARKING SYMBOLS & CHARACTERS	55 EA	100.00	5,500.00
0027	4890000000-E	SP	GENERIC PAVEMENT MARKING ITEM COLD APPLIED PLASTIC PAVEMENT MARKING LINES, TYPE II (9")	61,700 LF	7.50	462,750.00
0028	4895000000-N	SP	GENERIC PAVEMENT MARKING ITEM REMOVE AND REPLACE SNOWPLOW-ABLE PAVEMENT MARKERS	5,720 EA	75.00	429,000.00
0029	4905000000-N	1253	SNOWPLOWABLE PAVEMENT MARKERS	70 EA	31.00	2,170.00
0030	5255000000-N	1413	PORTABLE LIGHTING	Lump Sum LS	177,000.00	177,000.00
0031	6000000000-E	1605	TEMPORARY SILT FENCE	2,500 LF	3.00	7,500.00
0032	6071010000-E	SP	WATTLE	2,000 LF	10.00	20,000.00

Line #	ItemNumber	Sec #	Description	Quantity Unit	Unit Bid Price	Amount Bid
0033	8161000000-E	420	GROOVING BRIDGE FLOORS	120,541 SF	0.55	66,297.55
0034	8217000000-E	425	REINFORCING STEEL (BRIDGE)	1,348 LB	3.00	4,044.00
0035	8224000000-E	425	EPOXY COATED REINFORCING STEEL (BRIDGE)	5,433 LB	3.20	17,385.60
0036	8559000000-E	SP	CLASS II, SURFACE PREPARATION	4 SY	1,000.00	4,000.00
0037	8566000000-E	SP	CLASS III, SURFACE PREPARATION	82.3 SY	2,000.00	164,600.00
0038	8699000000-N	SP	STRIP SEALS	Lump Sum LS	20,000.00	20,000.00
0039	8860000000-N	SP	GENERIC STRUCTURE ITEM PARTIAL REMOVAL OF EXISTING STRUCTURE	Lump Sum LS	47,000.00	47,000.00
0040	8860000000-N	SP	GENERIC STRUCTURE ITEM VOLUMETRIC MIXER	Lump Sum LS	5,000.00	5,000.00
0041	8867000000-E	SP	GENERIC STRUCTURE ITEM EXPANSION JOINT SEAL REPAIR	410 LF	150.00	61,500.00
0042	8867000000-E	SP	GENERIC STRUCTURE ITEM FOAM JOINT SEALS	719 LF	170.00	122,230.00
0043	8881000000-E	SP	GENERIC STRUCTURE ITEM POLYESTER POLYMER CONCRETE MATERIALS	432.7 CY	3,000.00	1,298,100.00
0044	8882000000-E	SP	GENERIC STRUCTURE ITEM CONCRETE FOR DECK REPAIR	1,442.3 CF	89.00	128,364.70
0045	8889000000-E	SP	GENERIC STRUCTURE ITEM ADDITIONAL REINFORCING STEEL	1,200 LB	2.00	2,400.00
0046	8892000000-E	SP	GENERIC STRUCTURE ITEM BRIDGE JOINT DEMOLITION	73.8 SF	93.00	6,863.40
0047	8893000000-E	SP	GENERIC STRUCTURE ITEM CONCRETE DECK REPAIR FOR POLYESTER POLYMER CONC OVERLAY	4 SY	500.00	2,000.00
0048	8893000000-E	SP	GENERIC STRUCTURE ITEM PLACING & FINISHING POLYESTER POLYMER CONCRETE OVERLAY	14,139 SY	26.00	367,614.00
0049	8893000000-E	SP	GENERIC STRUCTURE ITEM SCARIFYING BRIDGE DECK	14,139 SY	17.00	240,363.00

Contract Item Sheets For C204116

Line #	ItemNumber	Sec #	Description	Quantity Unit	Unit Bid Price	Amount Bid
0050	8893000000-E	SP	GENERIC STRUCTURE ITEM SHOTBLASTING BRIDGE DECK	14,139 SY	3.50	49,486.50

---

TOTAL AMOUNT OF BID FOR ENTIRE PROJECT **\$10,608,928.84**

---

1034/Apr06/Q2228485.1/D276405420000/E50

Contract No. C204116  
County Mecklenburg

Rev. 1-16-18

**EXECUTION OF CONTRACT  
NON-COLLUSION, DEBARMENT AND GIFT BAN CERTIFICATION**

**CORPORATION**

The Contractor declares (or certifies, verifies, or states) under penalty of perjury under the laws of the United States that neither he, nor any official, agent or employee has entered into any agreement, participated in any collusion, or otherwise taken any action which is in restraint of free competitive bidding in connection with this Contract, that the Contractor has not been convicted of violating *N.C.G.S. § 133-24* within the last three years, and that the Contractor intends to do the work with its own bonafide employees or subcontractors and did not bid for the benefit of another contractor.

By submitting this Execution of Contract, Non-Collusion and Debarment Certification, the Contractor is certifying his status under penalty of perjury under the laws of the United States in accordance with the Debarment Certification attached, provided that the Debarment Certification also includes any required statements concerning exceptions that are applicable.

*N.C.G.S. § 133-32* and Executive Order 24 prohibit the offer to, or acceptance by, any State Employee of any gift from anyone with a contract with the State, or from any person seeking to do business with the State. By execution of any response in this procurement, you attest, for your entire organization and its employees or agents, that you are not aware that any such gift has been offered, accepted, or promised by any employees of your organization.

**SIGNATURE OF CONTRACTOR**

Crowder Construction Company

Full name of Corporation

P.O. Box 30007, Charlotte, NC 28230

Address as Prequalified

Attest

  
~~Secretary/Assistant Secretary~~  
Select appropriate title

By

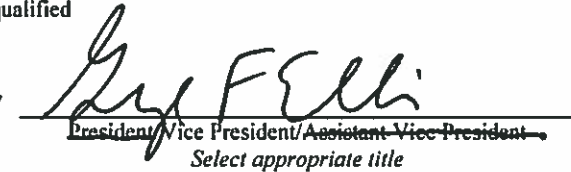
  
~~President/Vice President/Assistant Vice President~~  
Select appropriate title

Terry Matthews

Print or type Signer's name

George F. Ellis

Print or type Signer's name



## DEBARMENT CERTIFICATION

### Conditions for certification:

1. The prequalified bidder shall provide immediate written notice to the Department if at any time the bidder learns that his certification was erroneous when he submitted his debarment certification or explanation filed with the Department, or has become erroneous because of changed circumstances.
2. The terms *covered transaction, debarred, suspended, ineligible, lower tier covered transaction, participant, person, primary covered transaction, principal, proposal, and voluntarily excluded*, as used in this provision, have the meanings set out in the Definitions and Coverage sections of the rules implementing Executive Order 12549. A copy of the Federal Rules requiring this certification and detailing the definitions and coverages may be obtained from the Contract Officer of the Department.
3. The prequalified bidder agrees by submitting this form, that he will not knowingly enter into any lower tier covered transaction with a person who is debarred, suspended, declared ineligible, or voluntarily excluded from participation in NCDOT contracts, unless authorized by the Department.
4. For Federal Aid projects, the prequalified bidder further agrees that by submitting this form he will include the Federal-Aid Provision titled *Required Contract Provisions Federal-Aid Construction Contract (Form FHWA PR 1273)* provided by the Department, without subsequent modification, in all lower tier covered transactions.
5. The prequalified bidder may rely upon a certification of a participant in a lower tier covered transaction that he is not debarred, suspended, ineligible, or voluntarily excluded from the covered transaction, unless he knows that the certification is erroneous. The bidder may decide the method and frequency by which he will determine the eligibility of his subcontractors.
6. Nothing contained in the foregoing shall be construed to require establishment of a system of records in order to render in good faith the certification required by this provision. The knowledge and information of a participant is not required to exceed that which is normally possessed by a prudent person in the ordinary course of business dealings.
7. Except as authorized in paragraph 6 herein, the Department may terminate any contract if the bidder knowingly enters into a lower tier covered transaction with a person who is suspended, debarred, ineligible, or voluntarily excluded from participation in this transaction, in addition to other remedies available by the Federal Government.



### DEBARMENT CERTIFICATION

The prequalified bidder certifies to the best of his knowledge and belief, that he and his principals:

- a. Are not presently debarred, suspended, proposed for debarment, declared ineligible, or voluntarily excluded from covered transactions by any Federal department or agency;
- b. Have not within a three-year period preceding this proposal been convicted of or had a civil judgment rendered against them for commission of fraud or a criminal offense in connection with obtaining, attempting to obtain, or performing a public (Federal, State or local) transaction or contract under a public transaction; violation of Federal or State antitrust statutes or commission of embezzlement, theft, forgery, bribery, falsification or destruction of records; making false statements; or receiving stolen property;
- c. Are not presently indicted for or otherwise criminally or civilly charged by a governmental entity (Federal, State or local) with commission of any of the offenses enumerated in paragraph b. of this certification; and
- d. Have not within a three-year period preceding this proposal had one or more public transactions (Federal, State or local) terminated for cause or default.
- e. Will submit a revised Debarment Certification immediately if his status changes and will show in his bid proposal an explanation for the change in status.

If the prequalified bidder cannot certify that he is not debarred, he shall provide an explanation with this submittal. An explanation will not necessarily result in denial of participation in a contract.

Failure to submit a non-collusion and debarment certification will result in the prequalified bidder's bid being considered non-responsive.

Check here if an explanation is attached to this certification.

**Contract No.**     **C204116**

**County (ies):**    **Mecklenburg**

ACCEPTED BY THE  
DEPARTMENT OF TRANSPORTATION

DocuSigned by:  
*Ronald E. Davenport, Jr.*  
F81B6038A47A442...  
\_\_\_\_\_  
Contract Officer

4/13/2018  
\_\_\_\_\_  
Date

Execution of Contract and Bonds  
Approved as to Form:

DocuSigned by:  
*Colin Justice*  
1889E4C5ADF14AE...  
\_\_\_\_\_  
Attorney General

4/13/2018  
\_\_\_\_\_  
Date

Contract No C204116  
County Mecklenburg

**CONTRACT PAYMENT BOND**

Date of Payment Bond Execution 4/10/2018

Name of Principal Contractor Crowder Construction Company

Name of Surety: Liberty Mutual Insurance Company

Name of Contracting Body: North Carolina Department of Transportation  
Raleigh, North Carolina

Amount of Bond: Ten Million Six Hundred Eight Thousand Nine Hundred Twenty-Eight and 84/100 Dollars (\$10,608,928.84)

Contract ID No.: C204116

County Name: Mecklenburg

KNOW ALL MEN BY THESE PRESENTS, That we, the PRINCIPAL CONTRACTOR (hereafter, PRINCIPAL) and SURETY above named, are held and firmly bound unto the above named Contracting Body, hereinafter called the Contracting Body, in the penal sum of the amount stated above for the payment of which sum well and truly to be made, we bind ourselves, our heirs, executors, administrators, and successors, jointly and severally, firmly by these presents.

THE CONDITION OF THIS OBLIGATION IS SUCH, that whereas the principal entered into a certain contract with the Contracting Body, numbered as shown above and hereto attached:

NOW THEREFORE, if the principal shall promptly make payment to all persons supplying labor and material in the prosecution of the work provided for in said contract, and any and all duly authorized modifications of said contract that may hereafter be made, notice of which modifications to the surety being hereby waived, then this obligation to be void; otherwise to remain in full force and virtue.

IN WITNESS WHEREOF, the above-bound parties have executed this instrument under their several seals on the date indicated above, the name and corporate seal of each corporate party being hereto affixed and these presents duly signed by its undersigned representative, pursuant to authority of its governing body.

Contract No  
County

C204116  
Mecklenburg

Rev 5-17-11

**CONTRACT PAYMENT BOND**

*Affix Seal of Surety Company*

Liberty Mutual Insurance Company  
Print or type Surety Company Name



By John Dufresne, Attorney in Fact  
Print, stamp or type name of Attorney-in-Fact

  
Signature of Attorney-in-Fact

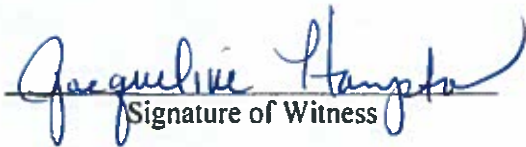
  
Signature of Witness

Jacqueline Hampton  
Print or type Signer's name

C/O USI Insurance Services  
6100 Fairview Road  
Charlotte, NC 28210  
Address of Attorney-in-Fact

Contract No C204116  
County Mecklenburg

Rev 5 17 11

**CONTRACT PAYMENT BOND**

**CORPORATION**

SIGNATURE OF CONTRACTOR (Principal)

Crowder Construction Company

Full name of Corporation

P.O. Box 30007, Charlotte, NC 28230  
Address as prequalified

By George F. Ellis  
Signature of ~~President, Vice President, Assistant Vice President~~  
Select appropriate title

George F. Ellis  
Print or type Signer's name

*Affix Corporate Seal*



Attest Terry Matthews  
Signature of ~~Secretary, Assistant Secretary~~  
Select appropriate title

TERRY MATTHEWS  
Print or type Signer's name

Contract No C204116  
County Mecklenburg

**CONTRACT PERFORMANCE BOND**

Date of Performance Bond Execution: 4/10/2018

Name of Principal Contractor: Crowder Construction Company

Name of Surety: Liberty Mutual Insurance Company

Name of Contracting Body: North Carolina Department of Transportation

Raleigh, North Carolina

Amount of Bond: Ten Million Six Hundred Eight Thousand Nine Hundred Twenty-Eight and 84/100 Dollars (\$10,608,928.84)

Contract ID No.: C204116

County Name: Mecklenburg

KNOW ALL MEN BY THESE PRESENTS, That we, the PRINCIPAL CONTRACTOR (hereafter, PRINCIPAL) and SURETY above named, are held and firmly bound unto the above named Contracting Body, hereinafter called the Contracting Body, in the penal sum of the amount stated above for the payment of which sum well and truly to be made, we bind ourselves, our heirs, executors, administrators, and successors, jointly and severally, firmly by these presents.

THE CONDITION OF THIS OBLIGATION IS SUCH, that whereas the principal entered into a certain contract with the Contracting Body, numbered as shown above and hereto attached:

NOW THEREFORE, if the principal shall well and truly perform and fulfill all the undertakings, covenants, terms, conditions, and agreements of said contract during the original term of said contract and any extensions thereof that may be granted by the Contracting Body, with or without notice to the Surety, and during the life of any guaranty required under the contract, and shall also well and truly perform and fulfill all the undertakings, covenants, terms, conditions, and agreements of any and all duly authorized modifications of said contract that may hereafter be made, notice of which modifications to the surety being hereby waived, then this obligation to be void; otherwise to remain in full force and virtue.

IN WITNESS WHEREOF, the above-bound parties have executed this instrument under their several seals on the date indicated above, the name and corporate seal of each corporate party being hereto affixed and these presents duly signed by its undersigned representative, pursuant to authority of its governing body.

Contract No C204116  
County Mecklenburg

Rev 5-17-11

### CONTRACT PERFORMANCE BOND

*Affix Seal of Surety Company*

Liberty Mutual Insurance Company  
Print or type Surety Company Name



By John Dufresne, Attorney in Fact  
Print, stamp or type name of Attorney-in-Fact

  
Signature of Attorney-in-Fact

  
Signature of Witness

Jacqueline Hampton  
Print or type Signer's name

C/O USI Insurance Services  
6100 Fairview Road  
Charlotte, NC 28210  
Address of Attorney-in-Fact

Contract No. C204116  
County Mecklenburg

Rev 5-17-11

**CONTRACT PERFORMANCE BOND  
CORPORATION**

SIGNATURE OF CONTRACTOR (Principal)

Crowder Construction Company

Full name of Corporation

P.O. Box 30007, CHARLOTTE, NC 28230  
Address as prequalified

By George F. Ellis  
Signature of ~~President~~ Vice President, Assistant Vice President  
Select appropriate title

George F. Ellis  
Print or type Signer's name

Affix Corporate Seal

Attest Terry Matthews  
Signature of ~~Secretary~~ Assistant Secretary  
Select appropriate title



Terry Matthews  
Print or type Signer's name



**THIS POWER OF ATTORNEY IS NOT VALID UNLESS IT IS PRINTED ON RED BACKGROUND.**

This Power of Attorney limits the acts of those named herein, and they have no authority to bind the Company except in the manner and to the extent herein stated.

Certificate No. 7950020

Liberty Mutual Insurance Company  
The Ohio Casualty Insurance Company West American Insurance Company

**POWER OF ATTORNEY**

KNOWN ALL PERSONS BY THESE PRESENTS. That The Ohio Casualty Insurance Company is a corporation duly organized under the laws of the State of New Hampshire, that Liberty Mutual Insurance Company is a corporation duly organized under the laws of the State of Massachusetts, and West American Insurance Company is a corporation duly organized under the laws of the State of Indiana (herein collectively called the "Companies"), pursuant to and by authority herein set forth, does hereby name, constitute and appoint, **John Dufresne; Jacqueline Hampton; Jennifer C. Hoehn; John D. Leak, III; William J. Quinn**

all of the city of Charlotte, state of NC each individually if there be more than one named, its true and lawful attorney-in-fact to make, execute, seal, acknowledge and deliver, for and on its behalf as surety and as its act and deed, any and all undertakings, bonds, recognizances and other surety obligations, in pursuance of these presents and shall be as binding upon the Companies as if they have been duly signed by the president and attested by the secretary of the Companies in their own proper persons.

IN WITNESS WHEREOF, this Power of Attorney has been subscribed by an authorized officer or official of the Companies and the corporate seals of the Companies have been affixed thereto this 29th day of November, 2017.



The Ohio Casualty Insurance Company  
Liberty Mutual Insurance Company  
West American Insurance Company

By: David M. Carey  
David M. Carey, Assistant Secretary

STATE OF PENNSYLVANIA ss  
COUNTY OF MONTGOMERY

On this 29th day of November, 2017, before me personally appeared David M. Carey, who acknowledged himself to be the Assistant Secretary of Liberty Mutual Insurance Company, The Ohio Casualty Company, and West American Insurance Company, and that he, as such, being authorized so to do, execute the foregoing instrument for the purposes therein contained by signing on behalf of the corporations by himself as a duly authorized officer.

IN WITNESS WHEREOF, I have hereunto subscribed my name and affixed my notarial seal at King of Prussia, Pennsylvania, on the day and year first above written.



COMMONWEALTH OF PENNSYLVANIA  
Notarial Seal  
Teresa Pastella, Notary Public  
Upper Merion Twp., Montgomery County  
My Commission Expires March 28, 2021  
Member, Pennsylvania Association of Notaries

By: Teresa Pastella  
Teresa Pastella, Notary Public

This Power of Attorney is made and executed pursuant to and by authority of the following By-laws and Authorizations of The Ohio Casualty Insurance Company, Liberty Mutual Insurance Company, and West American Insurance Company which resolutions are now in full force and effect reading as follows:

**ARTICLE IV – OFFICERS** – Section 12. Power of Attorney Any officer or other official of the Corporation authorized for that purpose in writing by the Chairman or the President, and subject to such limitation as the Chairman or the President may prescribe, shall appoint such attorneys-in-fact, as may be necessary to act in behalf of the Corporation to make, execute, seal, acknowledge and deliver as surety any and all undertakings, bonds, recognizances and other surety obligations. Such attorneys-in-fact, subject to the limitations set forth in their respective powers of attorney, shall have full power to bind the Corporation by their signature and execution of any such instruments and to attach thereto the seal of the Corporation. When so executed, such instruments shall be as binding as if signed by the President and attested to by the Secretary. Any power or authority granted to any representative or attorney-in-fact under the provisions of this article may be revoked at any time by the Board, the Chairman, the President or by the officer or officers granting such power or authority.

**ARTICLE XIII – Execution of Contracts – SECTION 5. Surety Bonds and Undertakings.** Any officer of the Company authorized for that purpose in writing by the chairman or the president, and subject to such limitations as the chairman or the president may prescribe, shall appoint such attorneys-in-fact, as may be necessary to act in behalf of the Company to make, execute, seal, acknowledge and deliver as surety any and all undertakings, bonds, recognizances and other surety obligations. Such attorneys-in-fact subject to the limitations set forth in their respective powers of attorney, shall have full power to bind the Company by their signature and execution of any such instruments and to attach thereto the seal of the Company. When so executed such instruments shall be as binding as if signed by the president and attested by the secretary.

**Certificate of Designation** – The President of the Company, acting pursuant to the Bylaws of the Company, authorizes David M. Carey, Assistant Secretary to appoint such attorneys-in-fact as may be necessary to act on behalf of the Company to make, execute, seal, acknowledge and deliver as surety any and all undertakings, bonds, recognizances and other surety obligations.

**Authorization** – By unanimous consent of the Company's Board of Directors, the Company consents that facsimile or mechanically reproduced signature of any assistant secretary of the Company, wherever appearing upon a certified copy of any power of attorney issued by the Company in connection with surety bonds, shall be valid and binding upon the Company with the same force and effect as though manually affixed.

I, Renee C. Llewellyn, the undersigned, Assistant Secretary, The Ohio Casualty Insurance Company, Liberty Mutual Insurance Company, and West American Insurance Company do hereby certify that the original power of attorney of which the foregoing is a full, true and correct copy of the Power of Attorney executed by said Companies, is in full force and effect and has not been revoked.

IN TESTIMONY WHEREOF, I have hereunto set my hand and affixed the seals of said Companies this 10 day of APRIL, 2018.



By: Renee C. Llewellyn  
Renee C. Llewellyn, Assistant Secretary

Not valid for mortgage, note, loan, letter of credit, currency rate, interest rate or residual value guarantees.

To confirm the validity of this Power of Attorney call 1-610-832-8240 between 9:00 am and 4:30 pm EST on any business day.